



Dr. Bbosa Science

This document is sponsored by
The Science Foundation College Kiwanga- Namanve
Uganda East Africa
Senior one to senior six
+256 778 633 682, 753 802709

Digital Teachers

Nurture your dreams

Based on, best for sciences

List of physical constants to be used

Acceleration due to gravity, g	9.81ms^{-2}
Electron charge, e	$1.6 \times 10^{-19}\text{C}$
Electron mass	$9.11 \times 10^{-31}\text{kg}$
Mass of the earth	$5.97 \times 10^{24}\text{kg}$
Plank's constant, h	$6.6 \times 10^{-34}\text{Js}$
Stefan's-Boltzmann's constant, σ	$5.67 \times 10^{-8}\text{Wm}^{-2}\text{K}^{-1}$
Radius of the earth	$6.4 \times 10^6\text{m}$
Radius of the sun	$7 \times 10^8\text{m}$
Radius of the earth's orbit about the sun	$1.5 \times 10^{11}\text{m}$
Speed of light in the vacuum, c	$3.0 \times 10^8\text{ms}^{-1}$
Thermal conductivity of copper	$390\text{Wm}^{-1}\text{K}^{-1}$
Thermal conductivity of aluminium	$210\text{Wm}^{-1}\text{K}^{-1}$
Specific heat capacity of water	$4.200\text{Jkg}^{-1}\text{K}^{-1}$
Universal gravitational constant	$6.67 \times 10^{-11}\text{Nm}^2\text{Kg}^{-2}$
Avogadro's number, N_A	$6.02 \times 10^{23}\text{mol}^{-1}$
Surface tension of water	$7.0 \times 10^{-2}\text{Nm}^{-1}$
Density of water	1000kgm^{-3}
Gas constant, R	$8.31\text{Jmol}^{-1}\text{K}^{-1}$
Charge to mass ratio, e/m	$1.8 \times 10^{11}\text{Ckg}^{-1}$
The constant, $\frac{1}{4\pi\epsilon_0}$	$9.0 \times 10^9\text{F}^{-1}\text{m}$
Faraday's constant, F	$9.65 \times 10^4\text{Cmol}^{-1}$
Thermal conductivity of Iron	$75\text{Wm}^{-1}\text{K}^{-1}$
Specific latent heat of fusion of Ice =	$3.3 \times 10^5\text{Jkg}^{-1}$

Permittivity of free space, μ_0	$4.0\pi \times 10^{-7} \text{Hm}^{-1}$
Permittivity of free space, ϵ_0	$8.85 \times 10^{-12} \text{Fm}^{-1}$
One electron volt	$1.6 \times 10^{-19} \text{J}$
Resistivity of Nichrome wire at 250C	$1.2 \times 10^{-6} \Omega \text{m}$
Specific heat capacity of copper	$400 \text{Jkg}^{-1} \text{K}^{-1}$

1. (a) (i) Distinguish between scalar and vector quantity. (01 mark)

A scalar quantity is a physical quantity with magnitude but no direction

A vector quantity is a physical quantity with both magnitude and direction

- (ii) Give two examples of each type of quantity. (02marks)

Examples of scalar quantities: volume area, distance speed

Examples of vector quantities: force, displacement, impulse, momentum, acceleration

- (b) A body of mass 0.2kg at rest is acted on by four forces of 2.8N, 6.0N, 4.5N and 1.2N as shown in the figure below.

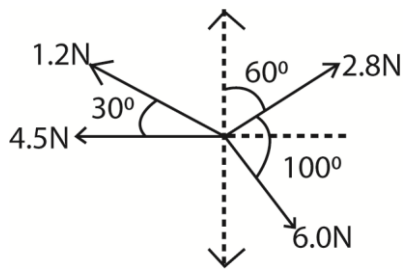

Calculate

- (i) Resultant force on the body (04marks)

$$F_x = 4.5 + 6\cos 70 + 2.8\cos 30 - 1.2\cos 30 = 7.94\text{N}$$

$$F_y = 0 - 6\sin 70 + 2.8\cos 30 + 1.2\sin 30 = -3.64\text{N}$$

$$\text{Magnitude of the resultant force} = \sqrt{7.94^2 + (-3.64)^2} = 8.73\text{N}$$

Direction

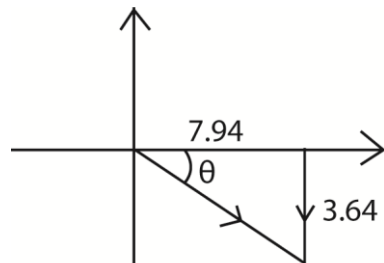

$$\tan \theta = \frac{3.64}{7.94}; \theta = 24.6^\circ$$

The resultant force is 8.73N in a direction 24.60 below the horizontal axis.

(ii) Distance moved in 4s (02marks)

Using $F = ma$

$$8.73 = 0.2a$$

$$a = 43.65 \text{ms}^{-1}$$

$$s = ut + \frac{1}{2} at^2$$

$$= 0 \times 4 + \frac{1}{2} \times 43.65 \times 4^2$$

$$= 349.2 \text{m}$$

(c) State Newton's law of motion and use them to derive the law of conservation of momentum. (06marks)

- A body continues in its state of rest or uniform motion in a straight line unless acted upon by an external force
- The rate of change of momentum of a body is directly proportional to applied force and takes place in the direction of the force
- For every action, there is an equal and opposite reaction

Derivation of the law of conservation of momentum

Let m_1, m_2 be the masses of two bodies initially moving in the same direction with velocities u_1 and u_2 which collide after time t , and gain velocities v_1 and v_2 respectively when $u_1 > u_2$.

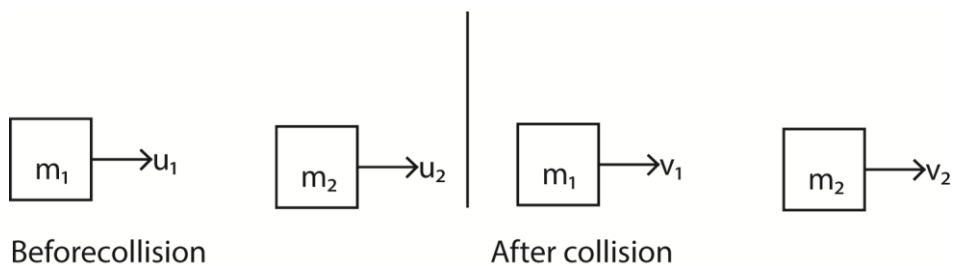

During collision, each body exerts a force of impact on each other according to Newton's second law of motion.

Let I be the impulse on A, then the impulse on B = $-I$.

$$I = M_1v_1 - m_1u_1 \dots\dots\dots (i)$$

$$-I = m_2v_2 - m_2u_2 \dots\dots\dots (ii)$$

Equation (i) + equation (ii)

$$0 = M_1v_1 - m_1u_1 + m_2v_2 - m_2u_2$$

$$m_1u_1 + m_2u_2 = m_1v_1 + m_2v_2$$

Alternatively

$$\text{From } F = ma = \frac{m(v-u)}{t}$$

$$\text{Force exerted by body of } m_1 \text{ on body of mass } m_2 = F_1 = \frac{m_1(v_1 - u_1)}{t}$$

$$\text{Force exerted by body of } m_2 \text{ on body of mass } m_1 = F_2 = \frac{m_2(v_2 - u_2)}{t}$$

Using Newton's third law, the forces are equal and opposite

$$F_1 = F_2$$

$$\frac{m_1(v_1 - u_1)}{t} = \frac{m_2(v_2 - u_2)}{t}$$

$$m_1u_1 + m_2u_2 = m_1v_1 + m_2v_2$$

(d) A body of mass 800kg moving at 30ms^{-1} collides with another of mass 400kg moving in the same direction at 25ms^{-1} . The two bodies stick together after collision. Calculate the

(i) common velocity just after collision (02marks)

$$m_1u_1 + m_2u_2 = (m_1 + m_2)v$$

$$(800 \times 30) + (400 \times 25) = (800 + 400)V$$

$$v = 28.3\text{ms}^{-1}$$

(ii) kinetic energy lost during collision (03marks)

Kinetic energy lost = kinetic energy before – kinetic energy after

$$\begin{aligned} &= \frac{1}{2} \times 800 \times 30^2 + \frac{1}{2} \times 400 \times 25^2 - \frac{1}{2} \times 1200 \times 28.3^2 \\ &= 4,466\text{J} \end{aligned}$$

2. (a) Define moment of force and give its SI unit. (02marks)

Moment of force is the product of force and perpendicular distance from the line of action of the force to the pivot. S.I units Nm.

(b) Explain briefly how to locate the centre of gravity of an irregular sheet of cardboard. (04marks)

- three holes are drilled around the edge of the cardboard.
- The cardboard is suspended from a pin through one of the holes. When the cardboard is freely suspended, a plumb line is suspended from the same pin.
- A line is drawn to mark the line where the plumb line passes.
- The procedure is repeated for the other two holes.
- The point of intersection of the three line is the centre of gravity

(c) State the conditions necessary for equilibrium of a rigid body under action of a system of forces. (02marks)

- The sum of clock wise moments about a fixed point is equal to the sum of anticlockwise moments about the same point.

(d) A wheel of radius 0.5m rests on a level surface at point C and makes contact with edge E of a block height 0.2m as shown in the figure below.

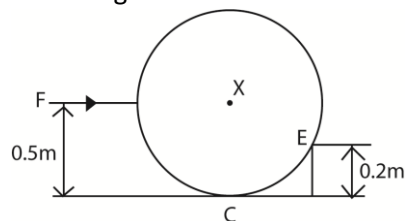

A force F is applied horizontally through the axle of the wheel at X to just move the wheel over the block. If the weight of the wheel is 180N , find the

- (i) Force exerted at point E (02marks)

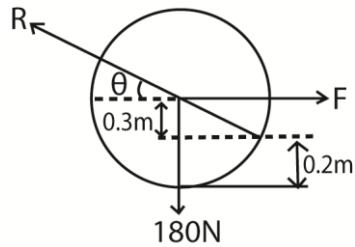

$$R \sin \theta = 180$$

$$R \times \frac{3}{5} = 180$$

$$R = 300\text{N}$$

The force exerted = 300N

- (ii) Force F (04marks)

$$F - R \cos \theta = 300 \cos 69.9^\circ = 240\text{N}$$

- (e) State the laws of friction and explain each of them (06marks)

- Friction force oppose relative motion between surfaces in contact.
Explanation; surfaces have projections with small area. When in contact, the surfaces rest on each other's projection. Because of the actual area of contact being small, high pressures exist at the points of contact and a force which opposes motion is developed.
- Friction force is independent of area of contact provided normal reaction is constant.
Explanation; When the object is turned over so that different surfaces are presented, the actual area of contact is approximately the same
- The friction force is directly proportional to the normal reaction.
Explanation; when the load increases, the pressure at points of contact increases the actual area of contact producing stronger bonds and increases the degree of interlocks. A greater force is therefore required for motion to take place.

3. (a) Define the following as applied to circular motion:

- (i) Centripetal acceleration (01mark)

Centripetal acceleration is the rate of change of velocity of a body moving in a circular path.

- (ii) Period (01mark)

A period is the time taken to move once round a circular path

- (b) (i) Explain why a cyclist bends inward while going round a curved path. (03marks)

- (ii) Show that if θ is the angle of inclination of the cyclist to the vertical and μ is the coefficient of limiting friction between the ground and the bicycle tyres, then for safe riding $\tan \theta \leq \mu$. (04marks)

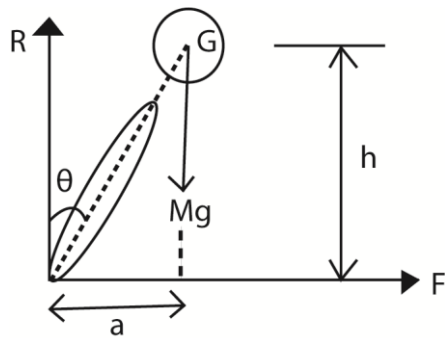

Taking moment about G,

$$F \times h = R \times a$$

$$- \tan \theta = \frac{a}{h} = \frac{F}{R}$$

$$- F = R \tan \theta$$

For safe riding, $F \leq F_1$ (limiting friction)

$$\text{But } F_1 = \mu R$$

$$\therefore R \tan \theta \leq \mu R$$

$$- \tan \theta = \mu$$

- (iii) A body of mass 1.5kg moves once round a circular path to cover 44.0cm in 5s. Calculate the centripetal force acting on the body. (04marks)

Radius of circular path, r

$$\text{Circumference} = 2\pi r = 44\text{cm}$$

$$r = \frac{44}{2\pi} = 7\text{cm}$$

$$\text{Linear velocity, } v = \frac{0.44}{5\text{s}} = 0.088\text{ms}^{-1}$$

$$\text{Centripetal force, } F = \frac{mv^2}{r} = \frac{1.5 \times 0.088^2}{7 \times 10^{-2}} = 0.166\text{N}$$

- (c) Define simple harmonic motion (01mark)

Simple harmonic motion is the motion of a body whose acceleration is directed towards a fixed point and is directly proportional to the displacement of the body from a fixed point.

- (d) A body executes simple harmonic motion with amplitude A and angular velocity, ω .

- (i) Write down the equation for velocity of the body at a displacement x from the mean position (01mark)

$$v^2 = \omega^2(A^2 - x^2)$$

$$v = \omega \sqrt{A^2 - x^2}$$

- (ii) Sketch the velocity-displacement graph for the body in (d)(i) for $\omega < 1$. (02marks)

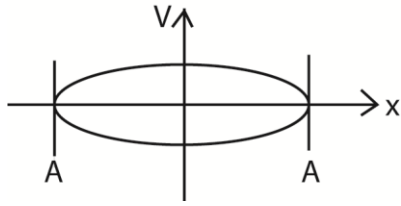

- (iii) If the body moves with amplitude 14.142 cm, at what distance from the mean position will be kinetic energy equal to potential energy? (03marks)

Kinetic energy = half of total energy

$$= \frac{1}{2} m \omega^2 (A^2 - x^2)$$

$$\text{Total energy} = \frac{1}{2} m \omega^2 A^2$$

$$- \frac{1}{2} m \omega^2 (A^2 - x^2) = \frac{1}{2} \left(\frac{1}{2} m \omega^2 A^2 \right)$$

$$A^2 - x^2 = \frac{A^2}{2}$$

$$x = \frac{A}{\sqrt{2}} = \frac{14.142}{\sqrt{2}} = 10 \text{ cm}$$

4. (a) State and illustrate Archimedes' principle. (05marks)

Archimedes' Principle: when a body is wholly or partially immersed in a fluid, it experiences an up thrust force equal to the weight of the fluid displaced.

Illustrating diagram

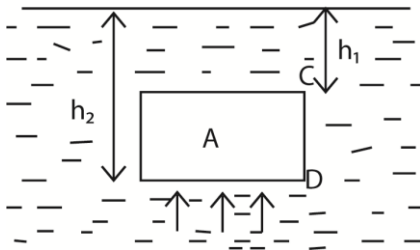

$$F_c = h_1 \rho g A, F_d = h_2 \rho g A$$

$$\text{Net force (up thrust)} = (h_2 - h_1) \rho g A$$

$$\text{Volume of liquid displaced} = (h_2 - h_1) A$$

$$\text{Weight of liquid displaced} = (h_2 - h_1) \rho g A$$

Hence up thrust = weight of liquid displaced

- (b)(i) State the law of flotation (01 marks)

A floating body displaces its own weight of fluid in which it floats.

- (ii) Describe an experiment to verify the law in (b)(i). (05marks)

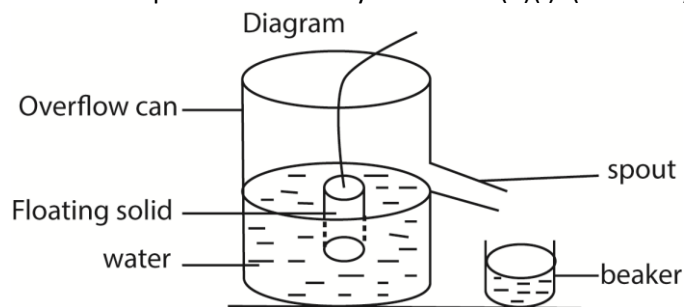

- Overflow can is filled with water up to spout level
- An object is lowered in the can until it floats.
- The displaced water is collected in the beaker.

- The weight of the displaced water is determined and found to be equal to the weight of the object.

(c) (i) Write Bernoulli's equation and define each term in the equation. (02marks)

$$P + \frac{1}{2}\rho v^2 + h\rho g = \text{constant}$$

Where P= pressure, $\frac{1}{2}\rho v^2$ = kinetic energy, $h\rho g$ = potential energy per unit volume.

(ii) Explain the origin of lift force on the wings of a plane. (03marks)

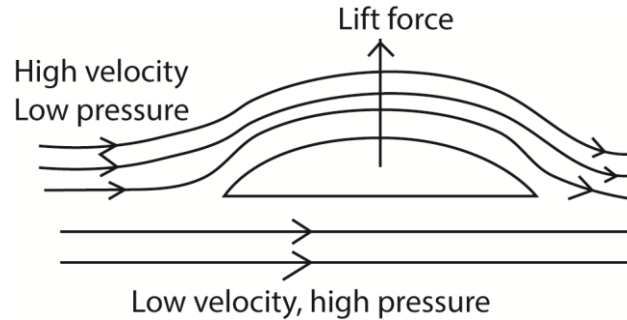

- Air flows above the wing of a plane at high velocity hence low pressure.
- Below the wings, air flows at low velocity and hence high pressure.
- The difference in pressure cause a lift force, therefore net upward force.

(iv) Air flows over the upper surfaces of the wings of an aeroplane at a speed of 120ms^{-1} , and past the lower surface of the wings at 110ms^{-1} . Calculate the lift force on the aeroplane if it has a total wing area of 20m^2 . Density of air = 1.29kgm^{-3}

$$P = \frac{1}{2}\rho(v_2^2 - v_1^2)$$

$$F = PA = \frac{1}{2} \times 1.29(120^2 - 110^2) \times 20 = 2.97 \times 10^4\text{N}$$

5. (a) What is meant by relative velocity? (01mark)

Relative velocity is the velocity of a body moves as observed from another body.

(b) A ship is heading due to north at a speed of 30ms^{-1} . Water in the lake is moving in the north-east direction at an average speed of 5kmh^{-1} . Calculate

(i) relative velocity of the ship (04 marks)

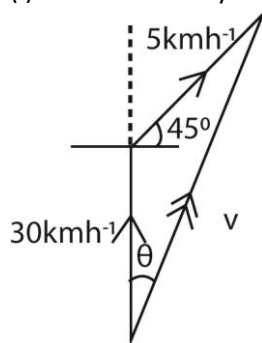

$$v_x = 5 \cos 45^\circ = 3.536$$

$$v_y = 30 + 5 \sin 45^\circ = 33.536$$

$$v = \sqrt{v_x^2 + v_y^2} = \sqrt{3.536^2 + 33.536^2} = 33.72\text{ms}^{-1}$$

$$\text{Direction of } v; \frac{5}{\sin \theta} = \frac{33.72}{\sin 135}$$

$$\theta = 6.0^\circ$$

(ii) distance off course the ship will be after 40 minutes. (02marks)

$$\text{Distance, } d = v_x t = 5 \sin 45^\circ \times \frac{40}{60} = 2.36 \text{ km}$$

(c) (i) Explain why a passenger in a car jerks forward when the brakes are suddenly applied. (03marks)

Before the brakes are applied, both the passenger and the car are moving with the same velocity. When brakes are applied, the force is exerted on the car and not the passenger. Because of inertia, the passenger tends to continue moving in a straight line.

(ii) Use Newton's second law to define the Newton. (04marks)

Consider a body of fixed mass, m acted on by constant force F and its velocity changes from u to v in time, t .

$$\text{Change in momentum} = \frac{(mv - mu)}{t}$$

$$\text{From Newton's second law; } F \propto \frac{(mv - mu)}{t} \text{ or } F = km \frac{(mv - mu)}{t}$$

$$\text{But } \frac{(mv - mu)}{t} = a$$

$$F = kma$$

$$\text{For } 1\text{N, } m = 1\text{kg, } a = 1\text{ms}^{-2} \Rightarrow k = 1$$

$$\therefore F = ma$$

The newton is a force which gives a mass of kg an acceleration of 1ms^{-2} .

(d) Three forces of 8.0N, 12.5N and 2.0N act on a body of mass 0.7kg as shown below

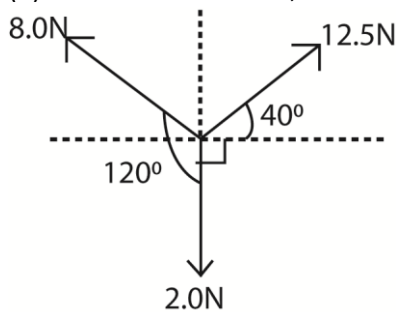

Calculate the acceleration of the body

$$F_x = 12.5 \cos 40^\circ - 8.0 \cos 30^\circ + 0 = 2.65 \text{ N}$$

$$F_y = 12.5 \sin 40^\circ + 8.0 \sin 30^\circ - 2 = 10.03 \text{ N}$$

$$\text{Resultant force } F = \sqrt{2.65^2 + 10.03^2} = 10.37 \text{ N}$$

$$F = ma$$

$$\text{Acceleration, } a = \frac{10.37}{0.7} = 14.82 \text{ ms}^{-2}$$

Direction

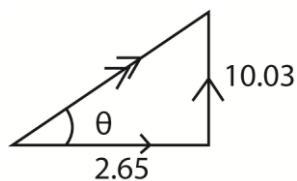

$$\tan \theta = \frac{10.03}{2.65}; \theta = 75.2^\circ$$

6. (a) what is meant by the centre of the mass? (01mark)

Centre of the mass is a point at which the whole mass of a body is considered to be concentrated.

(b) Explain why a long spanner is preferred to a short one in undoing a tight bolt. (03marks)

Undoing a tight nut is due to moment of a force. A long spanner provides a greater moment of force than a short one hence less force is applied.

(c) A uniform ladder of length 10m and weight 400N, leans against a smooth wall and its foot rests on rough ground. The ladder makes an angle of 60° with the horizontal. If the ladder just slips when a person of weight 800N climbs 6m up the ladder, calculate the
(i) reaction on the wall and the ground (05marks)

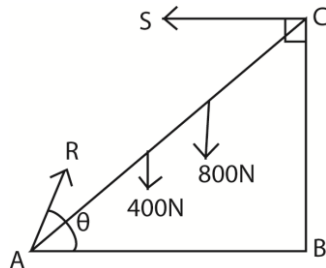

$$R \cos \theta = S$$

$$R \sin \theta = 1200$$

Taking moments about point A

$$400 \times 5 \cos 60^\circ + 800 \times 6 \cos 60^\circ = s \times 10 \sin 60^\circ$$

$$S = 392.6 \text{ N}$$

$$\tan \theta = \frac{1200}{392.6} \Rightarrow \theta = 71.9^\circ$$

$$R = \frac{1200}{\sin 71.9} = 1262.6 \text{ N}$$

(ii) distance another person of weight 600N can climb up the ladder so that the same reaction are exerted as in (c)(i). (02marks)

$$400 \times 5 \cos 60^\circ + L \cos 60^\circ \times 600 = 392.6 \times 10 \sin 60^\circ$$

$$L = 0.8 \text{ m}$$

(d) (i) State the principle of conservation of energy. (01mark)

Energy can neither be created nor destroyed but can be changed from form to another.

(ii) How does the principle in (d)(i) apply to a child sliding down an incline? (02marks)

Moving down an incline; potential energy is changed to kinetic energy to heat and sound

(e) A pump with power output of 147.1W can raise 2kg of water per second through a height of 5m and deliver it into a tank. Calculate the speed with which the water is delivered into the tank. (03marks)

Power x time = kinetic energy of water + potential energy

$$= \frac{1}{2} m v^2 + m g h$$

$$147.1 = \frac{1}{2} \times 2 \times v^2 + 2 \times 5 \times 9.81$$

$$v = 7.0 \text{ ms}^{-2}$$

(f) Explain the effect of a **couple** on a rigid body. (03marks)

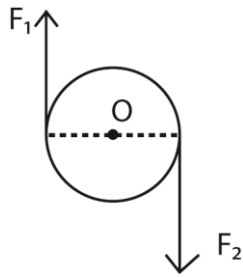

A **couple** consists of two parallel forces that are equal in magnitude, opposite in sense and do not share a line of action

7. (a) What is meant by a

(i) Brittle material (01mark)

A brittle material is a substance that breaks easily when a force is exerted on it e.g. glass

(ii) Ductile material (01marks)

A ductile material is one that can be hammered, rolled or moulded into different shapes.

(b) Give one example of each of the materials in (a) (01mark)

Brittle material: glass, clay, cast iron, stone

Ductile material: copper, aluminium

(c) Explain why bicycle frame are hollow (02mark)

Bicycle frame is hollow to reduce weight while maintain strength. A tube is significantly tougher to bend than a rod.

(d) (i) Sketch a labelled graph of stress against strain for a ductile material (02marks)

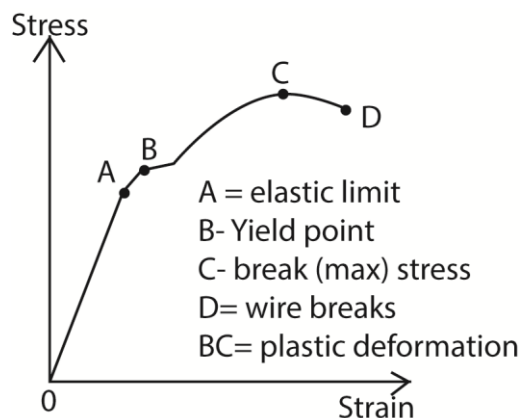

(ii) Explain the main features of the graph in (d)(i) (04marks)

- OA – stress is proportional to strain and the material regains its length
- AB - stress is not proportional to strain but the material regains its length
- Beyond B the material becomes permanently stretched
- CD the material undergoes plastic deformation
- Beyond D the material breaks

(e) Derive the expression for the energy stored per unit volume in a rod of length, L, Young's Modulus, Y, when stretched through distance, e. (04marks)

$$\text{Energy stored in the rod} = \frac{1}{2} Fe$$

$$\therefore \text{Energy stored per unit volume} = \frac{\frac{1}{2} Fe}{AL}$$

$$\text{But } F = \frac{Y Ae}{L}$$

$$\text{Energy stored per unit volume} = \frac{1}{2} \times \frac{Y Ae \cdot e}{AL^2} = \frac{1}{2} Y \left(\frac{e}{L} \right)^2$$

Or

For a small extension, dx

$$\text{Work done, } dw = F dx$$

From Hooke's law, $F = kx$

$$\therefore dw = kx dx \Rightarrow \text{Total work done, } w = \int dw$$

$$w = \int_0^e kx dx$$

$$\text{Energy stored} = \left| \frac{kx^2}{2} \right|_0^e, \text{ but } k = \frac{YA}{L}$$

$$\Rightarrow \text{Energy stored} = \frac{1}{2} \times \frac{Y Ae^2}{L}$$

$$\text{Energy stored per unit volume} = \frac{1}{2} \times \frac{Y Ae \cdot e}{AL^2} = \frac{1}{2} Y \left(\frac{e}{L} \right)^2$$

(f) A load of 5kg is placed on top of a vertical brass rod of radius 10mm and length 50cm. if

(i) decrease in length (03marks)

$$F = mg = 5 \times 9.81$$

$$A = \pi r^2 = \pi (10 \times 10^{-3})^2$$

$$e = \frac{FL}{AY} = \frac{5 \times 9.81 \times 0.5}{\pi (10 \times 10^{-3})^2 \times 3.5 \times 10^{10}} = 2.23 \times 10^{-6} \text{ m}$$

(ii) energy stored in the rod. (02marks)

$$E = \frac{1}{2} Fe = \frac{1}{2} \times 5 \times 9.81 \times 2.23 \times 10^{-3} = 5.47 \times 10^{-5} \text{ J}$$

8. (a) Define the following:

(i) Angular velocity

Angular velocity is the rate of change of angular displacement.

(ii) Period

Period is the time taken to make one complete oscillation

(b) An object moves in a circular path of radius, r, with a constant velocity, V. Derive an expression for its acceleration. (04marks)

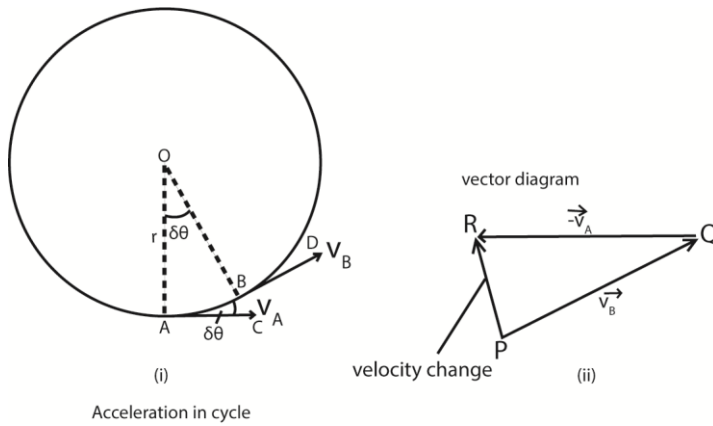

Acceleration in cycle

The velocity change from A to B = $v_B - v_A$ or $v_B + (-v_A)$.

In figure 2(ii) above, PQ represents v_B in magnitude (v) and direction BD; QR represents $-v_A$ in magnitude (v) and direction (CA).

Velocity change = $v_B + (-v_A) = PR$

When δt is small, the angle AOB or $\delta\theta$ is small;
Also angle PQR equal to $\delta\theta$ is small

PR or acceleration then points toward O, the centres of the circle.

$$a = \frac{\text{velocity change}}{\text{time}} = \frac{PR}{\delta t} = \frac{v\delta\theta}{\delta t}$$

$$\text{but } \frac{\delta\theta}{\delta t} = \omega \text{ and } v = r\omega$$

$$a = r\omega \times \omega = r\omega^2 \text{ but } \omega = \frac{v}{r}$$

$$- a = \frac{v^2}{r}$$

(c) (i) State two factors on which the rate of flow of a fluid through a tube depends.
(02marks)

- viscosity of fluid
- diameter/radius or cross sectional area of the tube
- pressure difference between its end

(ii) Describe an experiment to measure the coefficient of viscosity of a liquid using Ponselle's formula

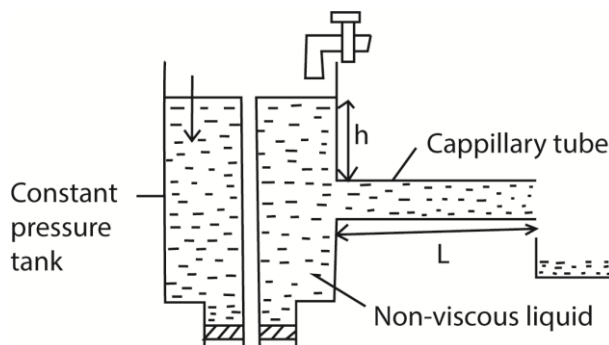

- the liquid of density, ρ , passes slowly from a constant head tank through a capillary tube of length, l and radius r .
- for a height, h , of the tube, the volume V is collect in time t .
- the flow rate $R = \frac{V}{t}$ is calculated
- the experiment is repeated for different value of V and h .
- a graph of R against h is plotted and slope S is obtained

$$\text{For steady flow, } S = \frac{\pi r^4 P}{8\eta l}$$

$$\text{But } P = h\rho g$$

$$r = \frac{d}{2}$$

$$S = \frac{\pi \left(\frac{d}{2}\right)^4 P}{8\eta l}$$

$$\eta = \frac{\pi \left(\frac{d}{2}\right)^4 h\rho g}{8Sl}$$

(d) Find the time take for an oil drop of diameter 6.0×10^{-3} mm to fall through a distance of 4.0 cm in air of coefficient of viscosity 1.8×10^{-5} Pa.

[The density of oil and air are 8.0×10^3 kgm⁻³ and 1kgm⁻³ respectively]

$$v = \frac{2r^2(P - \sigma)g}{9\eta} = \frac{2(3.0 \times 10^{-6})^2(800-1) \times 9.81}{9 \times 1.8 \times 10^{-5}} = 8.7 \times 10^{-4} \text{ms}^{-1}$$

$$\text{time} = \frac{\text{distance}}{\text{speed}} = \frac{4 \times 10^{-2}}{8.7 \times 10^{-4}} = 45.98 \text{s}$$

9. (a) (i) State Newton's laws of motion. (03marks)

- A body continues in its state of rest or uniform motion in a straight line unless acted upon by an external force
- The rate of change of momentum of a body is directly proportional to applied force and takes place in the direction of the force
- For every action, there is an equal and opposite reaction

(ii) A molecule of a gas contained in a cube of side L strikes the wall of the cube repeatedly with a velocity u . Show that the average force F on the wall is given by

$$F = \frac{mu^2}{L}; \text{ where } m \text{ is the mass of the molecule (04marks)}$$

$$\text{Change of momentum} = mu - (-mu) = 2mu$$

$$\text{Time between collision} = \frac{2l}{u}$$

$$\text{Force} = \frac{\text{change in momentum}}{\text{time}} = 2mu \div \frac{2l}{u} = \frac{mu^2}{l}$$

(b) (i) Define linear momentum and state the law of conservation of linear momentum. (02marks)

- Linear momentum is the product of mass and its velocity
- The law of conservation of linear momentum: if the resultant force on a system of interacting bodies is zero; total linear momentum is conserved.

- (ii) A body of mass m_1 moving with velocity u , collides with another body of mass m_2 at rest. If they stick together after collision, find the common velocity with which they move (04marks)

$$\text{Initial momentum} = m_1u + m_2 \times 0 = m_1u$$

$$\text{Final total momentum} = (m_1 + m_2)v$$

By conservation of linear momentum

$$m_1u = (m_1 + m_2)v$$

$$v = \frac{m_1u}{(m_1 + m_2)}$$

- (c) A bullet of mass 10g is fired horizontally with a velocity of 300ms^{-1} into a block of wood of mass 290g which rests on a rough horizontal floor. After impact, the block and the bullet move together and come to rest when the block has travelled a distance of 15m. Calculate the coefficient of sliding friction between the block and the floor. (07marks)

By conservation of linear momentum

$$\frac{10}{1000} \times 300 + \frac{290}{1000} \times 0 = \frac{(10+290)v}{1000}$$

$$v = 10\text{ms}^{-1}$$

$$\text{From } v^2 = u^2 + 2as$$

$$0 = 10^2 + 2a \times 15$$

$$a = -3.33\text{ms}^{-2}$$

Retarding force = frictional

$$\text{Force} = ma = \frac{300}{1000} \times \frac{10}{3} = 1\text{N}$$

$$\Rightarrow \frac{F}{mg} = \frac{1}{\frac{300}{1000}g} = 0.34$$

10. (a) State Kepler's laws of planetary motion. (03marks)

- Planets describe ellipses about the sun as one focus
- The imaginary line joining the sun and planet sweeps out equal areas in equal time intervals
- The square of the periodic time of revolution of planets about the sun are proportional to the cubes of their mean distance from the sun

- (b) Use Newton's law of gravity to derive the dimension of the universal gravitational constant (03marks)

$$F = \frac{GMm}{r^2}$$

$$\Rightarrow [G] = \frac{[F][r^2]}{[M][m]} = \frac{MLT^{-2} \cdot L^2}{M^2} = M^{-1}L^3T^{-2}$$

- (c) A satellite is revolving at a height, h , above the surface of the earth with period T .

- (i) Show that the acceleration due to gravity, g , on the earth's surface is given by

$$g = \frac{4\pi^2(r_e+h)^3}{T^2r_e^2}$$

where r_e is the radius of the earth. (06marks)

$$m(r_e + h)\omega^2 = \frac{GM_E m}{(r_e+h)} \text{ but } \omega = \frac{2\pi}{T}$$

$$\frac{4\pi^2}{T^2} = \frac{GM_E}{(r_e+h)^2} \text{ also, } GM_E = gr_e^2$$

$$\frac{4\pi^2}{T^2} = \frac{gr_e^2}{(r_e+h)^2}$$

$$g = \frac{4\pi^2(r_e+h)^2}{T^2r_e^2}$$

(ii) What is meant by parking orbit? (02marks)

Parking orbit of a satellite that it appears to be stationary to the observer on the earth's surface. The period of revolution of the satellite is equal to the period of revolution of the earth; i.e. $T = 24$ hours

(d) A satellite revolves in a circular orbit at a height of 600km above the earth's surface.

Calculate the

(i) speed of the satellite. (03marks)

$$v = \sqrt{\frac{gr_e^2}{R}} = \sqrt{\frac{9.81 \times (6.4 \times 10^6)^2}{(6.4 \times 10^6 + 6 \times 10^5)}} = 7.5764 \times 10^3 \text{ms}^{-1}$$

(ii) period of the satellite. (03marks)

$$T = \frac{2\pi((r_e+h))}{v} = \frac{2\pi(6.4 \times 10^6 + 6 \times 10^5)}{7.5764 \times 10^3} = 5802.2\text{s}$$

Or

$$T = \frac{2\pi}{r_e} \sqrt{\frac{(r_e+h)^3}{g}} = \frac{2\pi}{6.4 \times 10^6} \sqrt{\frac{(6.4 \times 10^6 + 6 \times 10^5)^3}{9.81}} = 5802.2\text{s}$$

11. (a)(i) Define Simple harmonic motion. (01mark)

Simple harmonic motion is the periodic motion of a body whose acceleration is directly proportional to the displacement of a body from a fixed point and it is directed towards the fixed point.

(ii) Sketch a displacement-time graph for a body performing simple harmonic motion. (01mark)

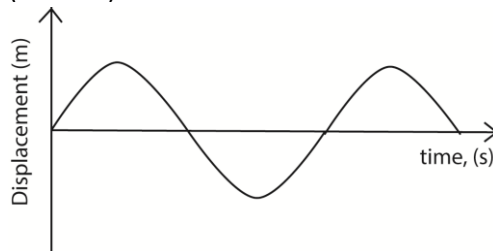

(b) A uniform cylindrical rod of length 16cm and density 920kgm^{-3} floats vertically in a liquid of density 1000kgm^{-3} . The rod is depressed through a distance of 7mm and then released.

(i) Show that the rod performs simple harmonic motion (06marks)

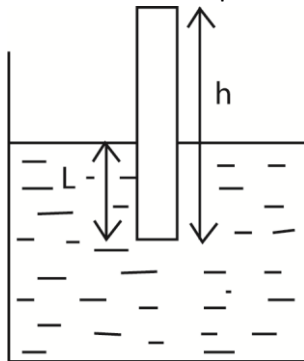

- Let A be the cross section area of the rod and ρ be the density of the liquid
- Weight of the liquid displaced = up thrust.
- The volume of the liquid displaced = AL and therefore up thrust, $u = AL\rho g$
- When the rod is slightly displaced through a distance x , the new up thrust, $u' = A(L+x)\rho g$
- Resultant force, $F + AL\rho g - A(L+x)\rho g = -A\rho gx$

But force, $F = ma = -A\rho gx$

$$\therefore a = -\left(\frac{A\rho g}{m}\right)x = -kx$$

Since $a \propto x$; the rod performs simple harmonic motion

(ii) Find the frequency of the resultant oscillations. (04marks)

$$\omega^2 = \frac{A\rho g}{m}; m = Ah\sigma \text{ (}\sigma \text{ = density of the rod)}$$

$$\omega^2 = \frac{A\rho g}{Ah\sigma} = \frac{\rho g}{h\sigma}; \text{ also } \omega = 2\pi f$$

$$f = \frac{1}{2\pi} \sqrt{\frac{\rho g}{h\sigma}} = \frac{1}{2\pi} \sqrt{\frac{1000 \times 9.81}{920 \times 0.16}} = 1.3 \text{ Hz}$$

(iii) Find the velocity of the rod when is at a distance of 5mm above the equilibrium position (03marks)

$$v = \omega \sqrt{(r^2 - x^2)} = 2\pi f \sqrt{(r^2 - x^2)} = 2\pi \times 1.3 \sqrt{0.007^2 - 0.005^2} = 0.04 \text{ ms}^{-1}$$

(c) What is meant by potential energy? (01mark)

Potential energy is the energy possessed by the body by the virtue of its position or state

(d) Describe the energy changes which occur when a

(i) ball thrown upwards in air (03marks)

Chemical energy \rightarrow P.E \rightarrow K.E + P.E \rightarrow P.E \rightarrow K.E + P.E \rightarrow K.E \rightarrow sound + heat

(ii) loud speaker vibrating (01mark)

Electrical energy \rightarrow mechanical energy \rightarrow sound

12. (a)(i) Define elastic deformation and plastic deformation (02marks)

- Elastic deformation is when a material is deformed and it regains its original shape and size when the deforming force is removed.
- Plastic deformation occurs when a force is applied and the material does not regain its original shape and size when the force is removed

(ii) Explain what is meant by work hardening. (02marks)

Work hardening is the strengthening of a material by repeatedly deforming it.

Atomic planes slide over each other, this increases plane dislocations which prevent further sliding of planes.

(b) (i) Sketch using the same axes, stress-strain curves for ductile material and for rubber (03marks)

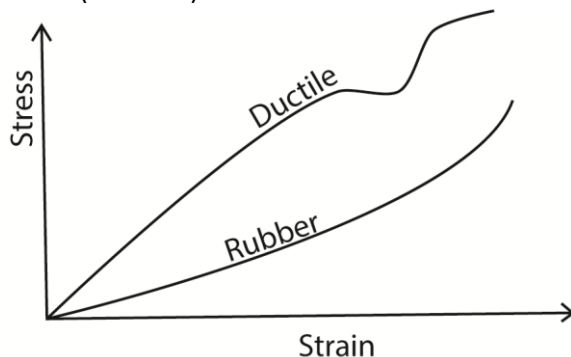

(ii) Explain the features of the curve for rubber. (03marks)

Rubber does not obey Hooke's law except for a very small range; it stretches easily without breaking and has a greatest range of elasticity. It does not undergo plastic deformation

Unstretched rubber consist of coiled molecules when a tensile force is applied, they uncoil, become straight and hard. Any further increase in tensile force makes the rubber to break.

- (c) A capillary tube is held in a vertical position with one end dipping in a liquid of surface tension γ and density ρ . If the liquid rises to a height, h , derive an expression for h in terms of γ , ρ and radius r of the tube assuming the angle of contact is zero. (04marks)

The liquid rises until the vertical component of the upward forces due to surface tension is equal to the weight of the liquid column.

$$F\gamma\cos\theta = W \text{ but } \theta = 0$$

$$\Rightarrow F\gamma = W$$

$$\gamma = \frac{F}{L}$$

$$F = \gamma L$$

$$L = 2\pi r$$

But $W = mg$ and $m = V\rho$ (where ρ is the density of the liquid in kg/m^3)

$$W = v\rho g = 2\pi r^2 h\rho g$$

$$F\gamma = 2\pi r^2 h\rho g$$

$$\gamma \cdot 2\pi r = 2\pi r^2 h\rho g$$

$$h = \frac{2\gamma}{r\rho g}$$

γ – coefficient of surface tension

θ – angle of contact

r – radius of capillary tube

ρ – density of the liquid

- (d) A mercury drop of radius 2mm falls vertically and on hitting the ground, it splits into two drops each of radius 0.5mm. Calculate the change in surface energy given that the surface tension of mercury is 0.52Nm^{-1} . (05marks)

$$\text{Surface area of a drop} = 4\pi r^2$$

$$\text{Surface area of a big drop} = 4\pi(0.002)^2 = 5.03 \times 10^{-5}\text{m}^2$$

$$\text{Surface area of two small drops} = 2 \times 4\pi(0.0005)^2 = 6.28 \times 10^{-6}\text{m}^2$$

$$\text{Change in area} = 5.03 \times 10^{-5} - 6.28 \times 10^{-6}\text{m}^2 = 4.402 \times 10^{-5}\text{m}^2$$

$$\text{Change in surface energy} = \text{change in area} \times \text{coefficient of surface tension}$$

$$= 4.402 \times 10^{-5} \times 0.52$$

$$= 2.289 \times 10^{-5}\text{J}$$

- (e) State the effect of temperature on surface tension of a liquid. (01mark)

Increase in temperature lowers surface tension

13. (a) (i) Define dimensions of a physical quantity. (01mark)

Dimensions of a physical quantity is the way it is related to fundamental quantities; mass, length and time

- (ii) In the gas equation

$$\left(P + \frac{a}{V^2}\right)(V - b) = RT$$

Where P = pressure, V = volume, T = absolute temperature and R = gas constant, what are the dimensions of the constants a and b ? (04mark)

$$\left[\frac{a}{V^2}\right] = [P] \text{ since it is added to } P$$

$$[P] = \frac{[Force]}{[Area]} = \frac{MLT^{-2}}{L^2} = ML^{-1}T^{-2}$$

$$[V] = L^3$$

$$\Rightarrow \frac{[a]}{[L^6]} = ML^{-1}T^{-2} \Rightarrow [a] = ML^5T^{-2}$$

$$[b] = [V] \text{ since } b \text{ is subtracted from } V$$

$$[b] = L^3$$

(b) A particle is projected from a point on horizontal plane with a velocity, u , at an angle, θ , above the horizontal. Show that the maximum horizontal range R_{\max} is given by,

$$R_{\max} = \frac{u^2}{g} \text{ where, } g, \text{ is the acceleration due to gravity. (04marks)}$$

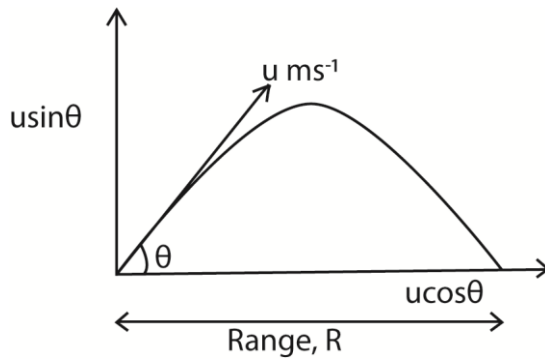

$$R = u \cos \theta \times \text{time of flight}$$

$$\text{Time of flight} = \frac{2u \sin \theta}{g}$$

$$\therefore \text{Range} = u \cos \theta \times \frac{2u \sin \theta}{g} = \frac{u^2 \sin 2\theta}{g}$$

$$\text{Form maximum range } \sin 2\theta = 1$$

$$\Rightarrow R_{\max} = \frac{u^2}{g}$$

(c) (i) Define elastic limit of a material. (01marks)

Elastic limit is the maximum load which a material can experience and still regain its original size and shape once the load has been removed.

(ii) Describe an experiment to determine Young's Modulus of a steel wire. (06marks)

Experiment to determine Young's Modulus for a metal wire

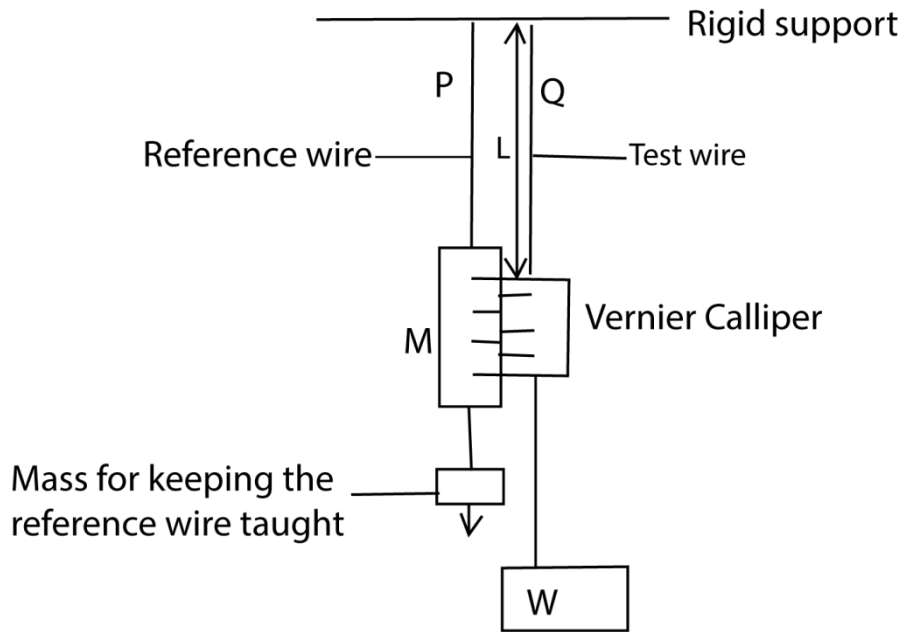

- (i) Two thin, long wires of the same material and length P and Q are suspended from a rigid support.
- (ii) P carries a scale M in mm and it's straightened by attaching a weight at its end.
- (iii) Q carries a Vernier scale which is alongside scale M
- (iv) Various loads are added to the test wire and corresponding extensions caused are read off from a vernier scale.
- (v) The diameter ($2r$) of the wire is obtained by a micrometre screw gauge, and the cross section area of the wire $A = 4\pi r^2$
- (vi) A graph of mass (m) of the load against extension e is plotted

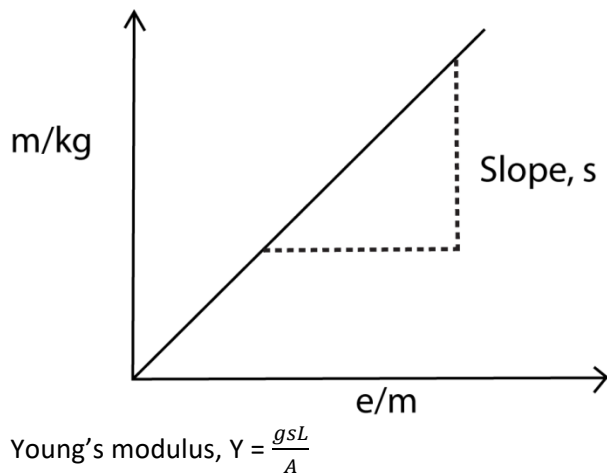

(d) Explain why tyres of a vehicle travelling on a hard surfaced road may burst. (04marks)

When the car moves on a hard surface, friction between the tyres and the surface causes overheating and the temperature inside the tyres increase. The increase in temperature increases the pressure inside the tyre which may lead to bursting.

14. (a) (i) What is meant by efficiency of a machine? (01mark)

Efficiency is the ratio of useful work done by a machine to the energy used by the machine; (expressed as percentage)

(ii) A car of mass $1.2 \times 10^3 \text{ kg}$ moves up an incline at a steady velocity of 15 ms^{-1} against a frictional force of $6.0 \times 10^3 \text{ N}$. The incline is such that the car rises 1.0 m for every 10 m along the incline. Calculate the output power of the car engine. (04marks)

$$F = mg \sin \theta + Fr$$

$$= 1.2 \times 10^3 \times 9.81 \times \frac{1}{10} + 6000 = 7177.2 \text{ N}$$

$$P = Fv$$

$$= 7177.2 \times 15 = 1.077 \times 10^5 \text{ W}$$

(b) (i) Define the impulse and momentum. (02marks)

- Impulse is a product of force and time of action of the force
- Momentum is a product of mass and its velocity

(ii) An engine pumps water such that the velocity of the water leaving the nozzle is 15 ms^{-1} . If the water jet is directed perpendicularly on a wall and comes to a stop at the wall, calculate the pressure exerted on the wall. (03marks)

$$\text{Force exerted on the wall, } F = \rho AV^2$$

$$\text{Pressure} = \frac{F}{A} = \rho V^2 = 1000 \times 15^2 = 2.25 \times 10^5 \text{ Nm}^{-2}$$

(c) (i) Define inertia. (01mark)

Inertia is the reluctance of a body to start moving once at rest or to stop moving once it has begun to move.

(ii) Explain why a body placed on a rough plane will slide when the angle of inclination is increased. (04marks)

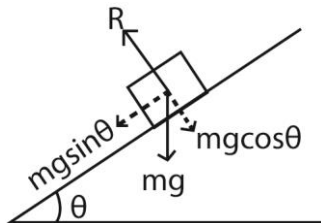

A body of mass, m placed on a plane inclined at an angle θ above the horizontal has its component $mg \sin \theta$ downwards along the plane. Since the plane is rough, $mg \sin \theta$ causes the frictional force F_r which prevents the body from sliding.

As θ increases, $mg \sin \theta$ exceeds maximum F_r and the body slides.

(d) (i) State the conditions for a body to be in equilibrium under action of coplanar forces. (02marks)

- Resultant force on the body is zero
- Algebraic sum of moments at any point is zero.

(ii) Briefly explain the three states of equilibrium (03marks)

- When a body in stable equilibrium is slightly displaced, its centre of gravity is raised. When released, it returns to its original position.
- When a body in stable equilibrium is slightly displaced, its centre of gravity is lowered and it continues to fall on release- topples.
- For neutral equilibrium, the centre of gravity remains the same on displacement.

15. (a) (i) What is meant by conservative forces? (01mark)

A conservative force is one for which the work done to move a body from one point to another is independent of the path taken and only depends on initial and final position of the body.

(ii) Give two examples of conservative forces (02marks)

- Mechanical energy
- Work done to move the body round a closed path.

(b) Explain the following

(i) damped oscillations (02marks)

Damped oscillations are oscillations in which the oscillatory system loses energy to the surroundings due to dissipative forces. The amplitude of the oscillations reduces with time.

(ii) Forced oscillations (02marks)

Force oscillations are those which are maintained by external force.

(c) (i) State Newton's law of gravitation (01mark)

Newton's law of gravitation states that every particle of matter attracts every other particle with a force which is directly proportional to the product of their masses and inversely proportional to the square of their distance apart.

(ii) Show that Newton's law of gravitation is consistent with Kepler's third law. (05marks)

Consider a planet of mass M_P moving around the sun of mass M_S in a circular orbit of radius r .

$$\text{Force due to gravitation, } F = \frac{GM_P M_S}{r^2}$$

$$\text{Force from circular motion, } F = \frac{M_P V^2}{r}$$

$$\text{But } \frac{GM_P M_S}{r^2} = \frac{M_P V^2}{r}$$

$$V^2 = \frac{GM_S}{r} \text{ also } V = \frac{2\pi r}{T}$$

$$\Rightarrow \left(\frac{2\pi r}{T}\right)^2 = \frac{GM_S}{r}$$

$$T^2 = \frac{4\pi^2 r^3}{GM_S} \text{ or } T^2 \propto r^3$$

(d) If the earth takes 365 days to make one revolution around the sun, calculate the mass of the sun (04marks)

$$M_S = \frac{4\pi^2 r^3}{GT^2} = \frac{4 \times \pi^2 \times (1.5 \times 10^{11})^3}{6.67 \times 10^{-11} \times (365 \times 24 \times 60 \times 60)^2} = 2.01 \times 10^{30} \text{ kg}$$

(e) Explain briefly how satellites are used in world-wide radio or television communication. (04marks)

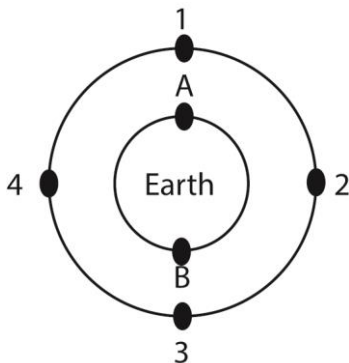

- A set of satellites is launched in parking orbit as shown in the diagram above.
- A radio signal from A is transmitted to a geosynchronous satellite 1

- The signals are retransmitted from satellite 1 to geosynchronous satellite 2, then to 3 and finally to B.
16. (a) (i) What is meant by fluid element and flow line as applied to fluid flow? (02mark)
- A fluid element is a molecule (the smallest volume) of the fluid which follows the flow.
 - A flow line is the path which individual molecule in a fluid element describes.
- (ii) Explain why some fluids flow more easily than others (03marks)
- Fluid flow involves different parts of a fluid moving at different velocities. Different parts of the fluid therefore slide past each other in layers. There exists frictional force between the layers which affects the flow rate. Liquids with low friction or viscosity flow faster than those with high viscosity.
- (b) (i) state Bernoulli's Principle. (01mark)
- Bernoulli's Principle states that for a streamline motion of an incompressible non viscous fluid, the sum of pressure at any point, the kinetic energy per unit volume is always constant.
- (ii) Explain how a Pilot-static tube works (04marks)

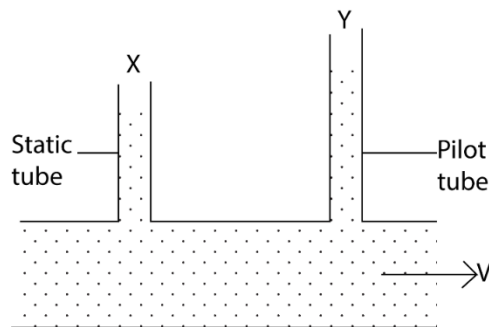

Pilot-static tube consists of a static tube which measure the static pressure and the pilot tube that measures the total pressure. Total pressure is the sum of static and dynamic pressure.

$$\text{From } P + \frac{1}{2}\rho v^2 + \rho gh = \text{constant}$$

$$\text{Static pressure} = P + \rho gh$$

$$\text{Dynamic pressure} = \frac{1}{2}\rho v^2$$

$$\text{Total pressure, } P_y = \text{static pressure } (P_x) + \text{dynamic pressure}$$

$$= P + \frac{1}{2}\rho v^2 + \rho gh$$

For horizontal tube, h is constant

$$\text{But, Total pressure, } P_y = \text{static pressure } (P_x) + \text{dynamic pressure}$$

$$P_y = P_x + \frac{1}{2}\rho v^2$$

$$(P_y - P_x) = \frac{1}{2}\rho v^2$$

$$v = \sqrt{\left(\frac{2(P_y - P_x)}{\rho}\right)}$$

- (c) Air flowing over the upper surface of an air craft's wing causes a lift force of $6.4 \times 10^5 \text{N}$. The air flows under the wing at a speed of 120ms^{-1} over an area of 28m^2 . Find the speed of air flow over an equal area of the upper surface of the air craft's wings. [Assume density of air = 1.2kgm^{-3}] (04marks)

$$P_b + \frac{1}{2}\rho V_b^2 = P_u + \frac{1}{2}\rho V_u^2$$

$$P_b A - P_u A = \frac{1}{2}\rho(V_u^2 - V_b^2)$$

$$6.4 \times 10^4 = \frac{1}{2} \times 1.2(V_u^2 - 120^2)$$

$$V_u = 121.6 \text{ms}^{-1}$$

(d) (i) What is meant by surface tension and angle of contact of a liquid? (02marks)

- Surface tension is the force per metre length acting in the surface at right angles to one side of the line drawn in the surface.
- Angle of contact is the angle between the solid surface and the tangent plane to the liquid surface measured through the liquid.

(ii) A water drop of radius 0.5cm is broken up into other drops of water each of radius 1mm. assuming isothermal conditions, find the total work done to break up the water drop. (04marks)

$$\text{Number of drops formed} = \frac{\frac{4}{3}\pi(0.5)^3}{\frac{4}{3}\pi(0.1)^3} = 125$$

$$\text{Total surface area} = 125 \times 4\pi r^2 = 125\pi \times 4 \times (0.1 \times 10^{-2})^2 = 1.57 \times 10^{-3} \text{m}^2$$

$$\text{Initial surface area} = 4\pi R^2 = 4\pi(0.5 \times 10^{-2})^2 = 3.14 \times 10^{-4} \text{m}^2$$

$$\begin{aligned} \text{Work done} &= \gamma \times \text{change in surface area} \\ &= 7.0 \times 10^{-2} (1.57 \times 10^{-3} - 3.14 \times 10^{-4}) \\ &= 8.8 \times 10^{-5} \text{J} \end{aligned}$$

17. (a) (i) what is meant by conservative force? (01mark)

Conservative force are forces for which the work done in moving a body around a closed path is zero.

Or

Conservative force is the one for which the work done in moving a body from one point to another is independent of the path taken.

(ii) Give two examples of conservative forces. (01mark)

- Gravitational force, magnetic force, electric force, elastic force

(b) (i) State the law of conservation of mechanical energy. (01mark)

The sum of kinetic energy and potential energy is constant in the absence of dissipative forces.

(ii) A body of mass, m, is projected vertically upwards with speed, u. show that the law of conservation of mechanical energy is obeyed throughout its motion. (05marks)

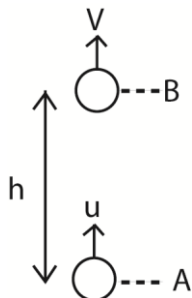

$$\text{At A, K.E} = \frac{1}{2}mu^2, \text{ P.E} = 0$$

$$\text{Total energy at A} = \text{K.E} + \text{P.E} = \frac{1}{2}mu^2 + 0 = \frac{1}{2}mu^2$$

$$\text{At B, K.E} = \frac{1}{2}mv^2; \text{ P.E} = mgh$$

$$\text{Total energy at B,} = \frac{1}{2}mv^2 + mgh$$

But $v^2 = u^2 - 2gh$

Total energy at B = $\frac{1}{2}m(u^2 - 2gh) + mgh = \frac{1}{2}mu^2$

∴ Total energy at A = total energy at B

(iii) Sketch a graph showing variation of kinetic energy by the body with time. (01 mark)

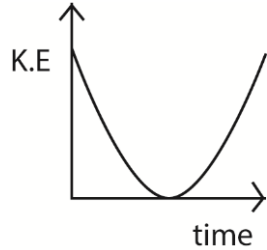

(c) (i) Describe an experiment to measure the coefficient of static friction. (04marks)

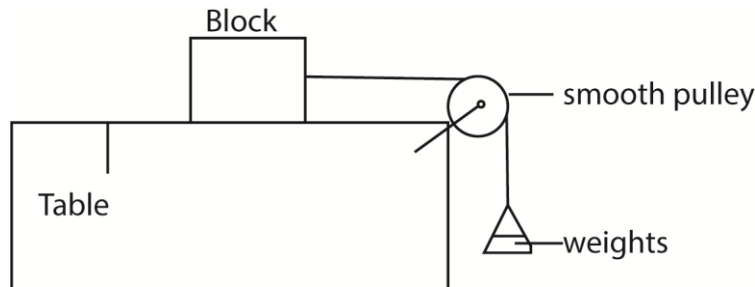

- A block of mass m is placed on a flat table and connected to a scale pan as shown in the diagram above.
- Small weights are added in bits on to the scale pan until the block just starts to move. The total weight of the scale pan and weights added is obtained, W_f .
- The coefficient of static friction, $\mu = \frac{W_f}{m.g}$

Alternative method

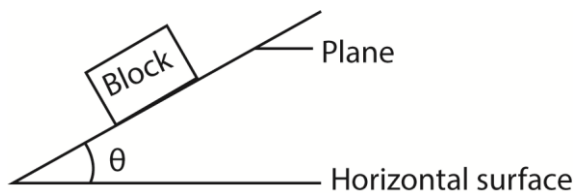

- A block is placed on horizontal plane. The plane is tilted gently until the block just start to slide
- The angle of tilt θ is measured
- The coefficient of static friction, $\mu = \tan\theta$

(ii) State two disadvantages of friction. (01mark)

- Wastes energy
- Causes wear and tear
- Causes noise
- Generates unnecessary heat

(d) A bullet of mass 20g moving horizontally strikes and get embedded in a wooden block of mass 500g resting on a horizontal table. The block slides through a distance of 2.3m before coming to rest. If the coefficient of kinetic friction between the block and table is 0.3, calculate

(i) friction force between the block and the table. (02marks)

$$F = \mu mg = 0.3 \times 0.52 \times 9.81 = 1.53\text{N}$$

(ii) velocity of the bullet just before it strikes the block. (04marks)

$$F = ma$$

$$-1.53 = 0.52a$$

$$a = -2.94\text{ms}^{-2}$$

$$v^2 = u^2 - 2as$$

$$0 = v_1^2 - 2 \times 2.94 \times 2.3$$

$$v_1 = 3.68\text{ms}^{-1}$$

$$Mu = (m + m_1)v_1$$

$$0.02u = 0.502 \times 3.68$$

$$u = 95.7\text{ms}^{-1}$$

18. (a) (i) State the principle of moments. (01mark)

When a body is in mechanical equilibrium, the sum of clockwise moments about any point is equal to the sum of anticlockwise moments about the same point

(ii) Define the terms centre of gravity and uniform body. (02marks)

- Centre of gravity is the point where the resultant force on the body due to gravity acts.
- A uniform body is one whose centre of gravity is the same as the geometrical centre.

(b) Figure below shows a body, M of mass 20kg supported by a rod of negligible mass horizontally hinged to a vertical wall and supported by a string fixed at 0.5m from the other end of the rod.

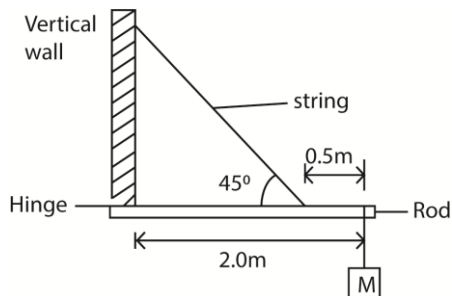

Calculate the

(i) Tension in the string (03marks)

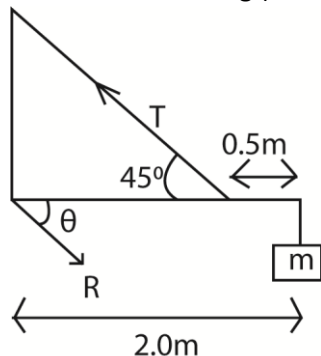

$$T \sin 45 \times 1.5 = 20 \times 9.81 \times 2$$

$$T = 370\text{N}$$

(ii) Reaction of the hinge (03marks)

$$R \cos \theta = 370 \cos 45 \dots\dots\dots(i)$$

Taking moments about O

$$R \sin \theta \times 1.5 = 20 \times 9.81 \times 0.5 \dots\dots(ii)$$

Eqn. (i) and (ii)

$$\theta = 14^\circ$$

- (iii) Maximum additional mass which can be added to the mass of 20kg before the string can break given that the string cannot support a tension of more than 500N. (02marks)

Taking moments about the hinge

$$500 \sin 45 \times 1.5 = X \times 9.81 \times 2$$

$$X = 27 \text{kg}$$

$$\text{extra mass} = 27 - 20 = 7 \text{kg}$$

- (c) (i) Define Young's modulus. (01marks)

Young's modulus is the ratio of tensile stress to tensile strain

- (ii) Explain the precautions taken in determinations of Young's modulus of a wire. (06marks)

- After each reading, the load is removed to check that the wire returns to its original length, to ensure that elastic limit is not exceeded.
- Long wires are used to achieve measurable expansion
- Thin wires are used to produce high tensile stress
- Identical wires are used to eliminate error of expansion or contraction due to changes in temperature.

- (iii) Explain why a piece of rubber stretches much more than a metal wire of the same length and cross section (02marks)

Rubber consist of coiled molecules while metal does not. When load is applied to rubber, the molecules uncoil leading to a larger extension

19. (a) State Kepler's laws of planetary motion (03marks)

- Planets revolve in elliptical orbits with the sun at the focus.
- The imaginary line joining the sun to any planet sweeps out equal areas in equal time intervals
- The square of the period of revolution of a planet is proportional to the cube of the mean distance from the sun to planet

- (b) (i) what is a parking orbit? (01mark)

A parking orbit is the path in space followed by a satellite whose period of revolution is equal to the period of rotation of the earth.

- (ii) Derive an expression for the period, T, of a satellite in a circular orbit of radius, r, above the earth in terms of mass of earth, m, gravitational constant, G and r. (04marks)

$$\frac{GmM_s}{r^2} = M_s r \omega^2 \text{ but } \omega = \frac{2\pi}{T}$$

$$\frac{Gm}{r^2} = r \left(\frac{4\pi^2}{T^2} \right)$$

$$T = 2\pi \sqrt{\frac{r^3}{Gm}}$$

- (c) (i) A satellite of mass 200kg is launched in a circular orbit at a height of $3.59 \times 10^7 \text{m}$ above the earth's surface. Find the mechanical energy of the satellite. (03marks)

$$\text{M.E} = \frac{-GMm}{2r} = \frac{-6.67 \times 10^{-11} \times 5.97 \times 10^{24} \times 200}{2(3.59 \times 10^7 + 6.4 \times 10^6)} = -9.41 \times 10^8$$

- (ii) Explain what will happen to the satellite if its mechanical energy was reduced.
(03marks)

When mechanical energy, $M.E = \frac{-GMm}{2r}$; is reduced, the satellite falls to orbit of smaller radius

- (d) Describe laboratory method of determining the universal gravitational constant, G.
(06marks)

Determining gravitational constant

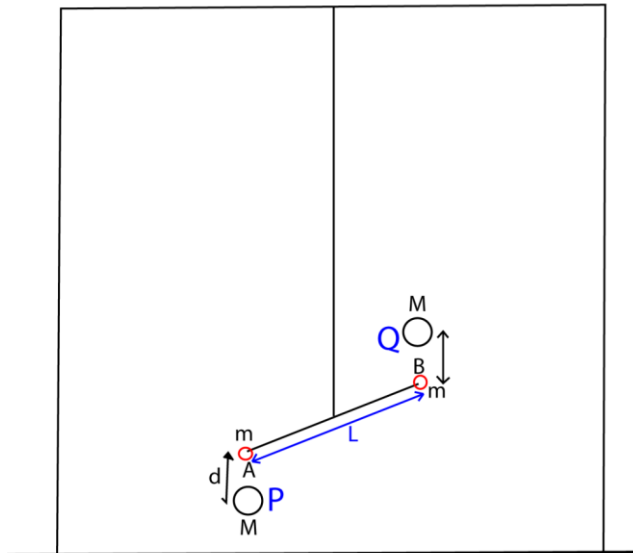

- Two equal lead spheres A and B each of mass, m, are attached to end of a bar AB of length, L.
- The bar AB is suspended from a ceiling.
- Large spheres P and Q are brought towards A and B respectively from the opposite side
- Large spheres P and Q alter small spheres A and B respectively by equal and opposite gravitational forces give rise to gravitational torque, F, which in turn twist the suspended through angle θ .
- A resting torque of the wire opposes the twisting of the wire from equilibrium position

Then

$$F = C\theta = \frac{GMm}{d^2}$$

$$G = \frac{C\theta d^2}{MmL}$$

Where

d = distance between the centre of A and P or B and Q.

C = the twisting couple per unit twist ($\theta = 1$)

20. (a) (i) Distinguish between surface tension and surface energy (01mark)

- Surface tension is a force per unit length acting at right angle to one side of an imaginary line drawn in the liquid surface
- Surface energy is the work done in increasing area of the surface by $1m^2$ under isothermal conditions.

- (ii) Show the surface energy and surface tension are numerically equal. (03marks)

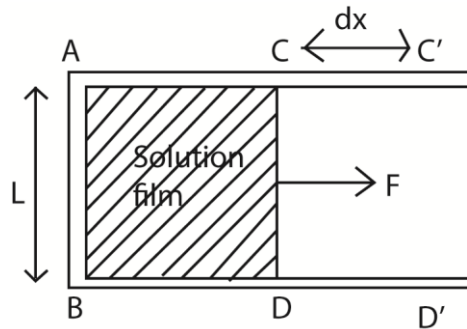

- F a wire frame ABCD is put in a solution of surface tension γ and a film of the solution forms on ABCD; and if a force F is used to extend the film to ABC'D' ;
 - Then surface tension, $\gamma = \frac{F}{2L}$
 - Surface energy, $\sigma = \frac{Fdx}{2Ldx} = \frac{2\gamma Ldx}{2Ldx} = \gamma$
- \therefore Surface energy, $\sigma =$ surface tension, γ

(iii) Explain why water dripping out of a tap does so in spherical shapes. (03marks)
 For any given volume, a sphere is a shape that offer minimum surface area and therefore the most stable

(b) Two soap bubbles of radius 2.0cm and 4.0cm respectively coalesce under isothermal conditions. If the surface tension of the soap solution is $2.5 \times 10^{-2} \text{Nm}^{-1}$, calculate the excess pressure inside the resulting soap bubble. (04marks)

$$2(\pi r_1^2) + 2(\pi r_2^2) = 2(\pi R^2)$$

$$R = \sqrt{r_1^2 + r_2^2} = \sqrt{2^2 + 4^2} = 4.47 \text{ cm}$$

$$P_1 - P_0 = \frac{4\gamma}{R} = \frac{4 \times 2.5 \times 10^{-2}}{4.47 \times 10^{-2}} = 2.24 \text{ Pa}$$

(c) (i) State Bernoulli's principle (0marks)

Bernoulli's Principle states that for a streamline motion of an incompressible non viscous fluid, the sum of pressure at any point and kinetic energy per unit volume is always constant.

(ii) Explain how wind at a high speed over the roof of a building can cause the roof to be ripped off the building. (03marks)

Wind blowing at a high speed over the roof of a building causes pressure above the roof to decrease below the pressure in the building where the wind is slow. This difference in pressure causes a resultant force that pushes the roof off the building.

(iii) An aeroplane has a mass of 8,000kg and wing area of 8.0m^2 . When moving through still air, the ratio of its velocity to that of the air above its wings is 0.25. At what velocity will the aeroplane be able to just lift off the ground? (Density of air = 1.3kgm^{-3})

- Minimum force to lift an aeroplane = $8000 \times 9.81 = 78480 \text{N}$
 - If v is the velocity of the aeroplane, then velocity of air below the wings $v_b = v$.
 - Velocity of the air above the aeroplane = $v_a = \frac{v}{0.25} = \frac{v_b}{0.25}$ or $v_a = 4v$
 - From Bernoulli's Principle, $P_b + \frac{1}{2}\rho v_b^2 = P_a + \frac{1}{2}\rho v_a^2$
- $$P_b - P_a = \frac{1}{2}\rho(v_a^2 - v_b^2) = \frac{1}{2} \times 1.3 ((4v)^2 - v^2) = 9.75v^2$$
- But force = pressure x area
- $$\Rightarrow 78480 = 9.75v^2 \times 8$$

$$v = 31.72\text{ms}^{-1}$$

21. (a)(i) What is projectile motion? (01 marks)

Projectile motion is motion of the body which after being given an initial velocity moves under the influence of gravity.

(ii) A bomb is dropped from an aeroplane when it is directly above a target at a height of 1402.5m. The aeroplane is moving horizontally with a speed of 500kmh⁻¹. Determine whether the bomb will hit the target. (05marks)

$$Y = ut + \frac{1}{2} at^2$$

$$-1402.2 = 0 + \frac{1}{2} \times 9.81 \times t^2$$

$$t = 16.9\text{s}$$

$$\text{Horizontal velocity of the plane} = 500\text{kmh}^{-1} = \frac{500 \times 1000}{60 \times 60} = 138.89\text{ms}^{-1}$$

$$\text{Distance of the bomb from the target} = 138.89 \times 16.9 = 2347.2\text{m}$$

Hence the bomb misses the target by 2347.2m

(b) (i) Define angular velocity. (01mark)

Angular velocity is the rate of change of angle for a body moving in a circular path.

(ii) A satellite is revolving around the earth in a circular orbit at an altitude of 6 x 10⁵m where the acceleration due to gravity is 9.4 ms⁻². Assuming that the earth is spherical, calculate the period of the satellite. (03marks)

$$Mg = mr\omega^2$$

$$g = \frac{4\pi^2 r}{T^2}$$

$$T = \sqrt{\left(\frac{4\pi^2(6.4 \times 10^6 + 6.0 \times 10^5)}{9.4}\right)} = 5.42 \times 10^3\text{s}$$

(c) (i) State Newton's laws of motion (03marks)

- A body continues in its state of rest or uniform motion in a straight line unless acted upon by an external force
- The rate of change of momentum of a body is directly proportional to applied force and takes place in the direction of the force
- For every action, there is an equal and opposite reaction

(ii) Explain how a rocket is kept in motion. (04marks)

Fuel is burnt in a combustion chamber and exhaust gases are expelled at high velocity. This causes a large backward momentum. From the principle of conservation of linear momentum, an equal forward momentum is gained by the rocket.

Due to continuous combustion of the fuel, there is a large change in forward momentum which leads to the thrust, hence maintaining the motion of the rocket.

(iii) Explain why passengers in a bus are thrown backwards when the bus suddenly starts moving (03marks)

Passengers are thrown backwards because of inertia. When the bus sets off the passengers tend to stay at rest because the force acts on the bus does not act on the passengers.

22. (a) (i) What is meant by Young's modulus? (03marks)

Young's Modulus is the ratio of tensile stress to tensile strain of a material

(ii) State Hooke's law (01mark)

Hooke's law states that the extension of a material is proportional to the stretching force provided the elastic limit is not exceeded.

- (iii) Derive an expression for energy released in a unit volume a stretched wire in terms of stress and strain. (04marks)

Suppose a force, F , stretches the wire by extension x

Work done, $W = \text{average force} \times \text{extension} = \frac{1}{2}Fx = \text{stored energy}$

Energy stored per unit volume $= \frac{W}{AL}$; where AL is the volume of the wire

Hence energy store $= \frac{1}{2} \times \left(\frac{F}{A}\right) \left(\frac{x}{L}\right) = \frac{1}{2} \times \text{stress} \times \text{strain}$

- (b) A steel wire of length 0.6m and cross-section area $1.5 \times 10^{-6} \text{m}^2$ is attached at B to a copper wire BC of length 0.39m and cross section area $3.0 \times 10^{-6} \text{m}^2$. The combination is suspended vertically from a fixed point at A and supports a weight of 250N at C. find the extension in each of the wires, given that Young's Modulus for steel is $2.0 \times 10^{11} \text{Nm}^{-2}$ and that of copper is $1.3 \times 10^{11} \text{Nm}^{-2}$. (05marks)

From $e = \frac{FL}{AE}$

For steel, $e_1 = \frac{250 \times 0.6}{1.5 \times 10^{-6} \times 2.0 \times 10^{11}} = 5.0 \times 10^{-4} \text{m}$

For copper, $e_2 = \frac{250 \times 0.39}{3.0 \times 10^{-6} \times 1.3 \times 10^{11}} = 2.5.0 \times 10^{-4} \text{m}$

- (c) With the aid of a labelled diagram, describe an experiment to determine the Young's Modulus of a steel wire (07marks)

Experiment to determine Young's Modulus for a metal wire

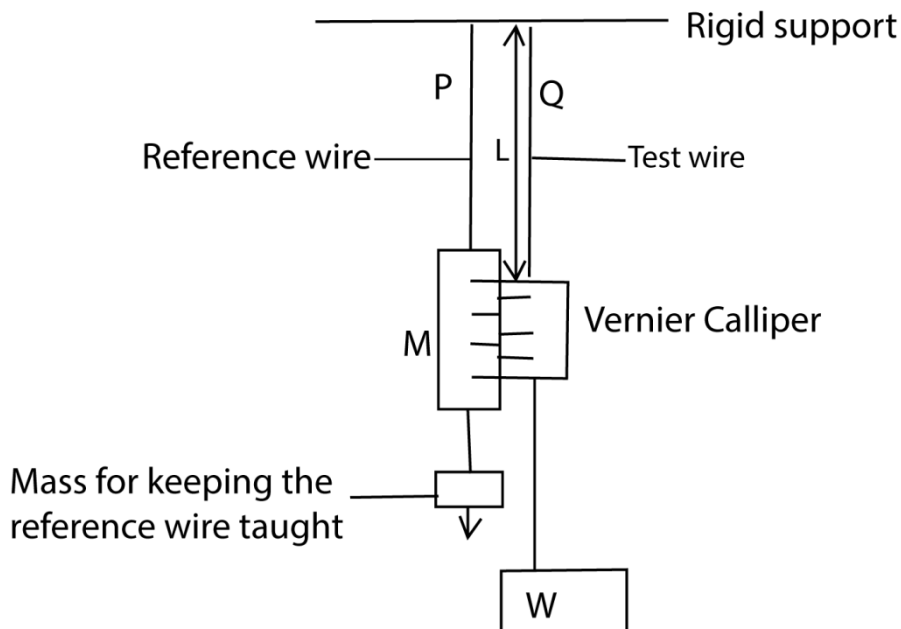

- (i) Two thin, long wires of the same material and length P and Q are suspended from a rigid support.
(ii) P carries a scale M in mm and it's straightened by attaching a weight at its end.

- (iii) Q carries a Vernier scale which is alongside scale M
- (iv) Various loads are added to the test wire and corresponding extensions caused are read off from a vernier scale.
- (v) The diameter ($2r$) of the wire is obtained by a micrometre screw gauge, and the cross section area of the wire $A = 4\pi r^2$
- (vi) A graph of mass (m) of the load against extension e is plotted

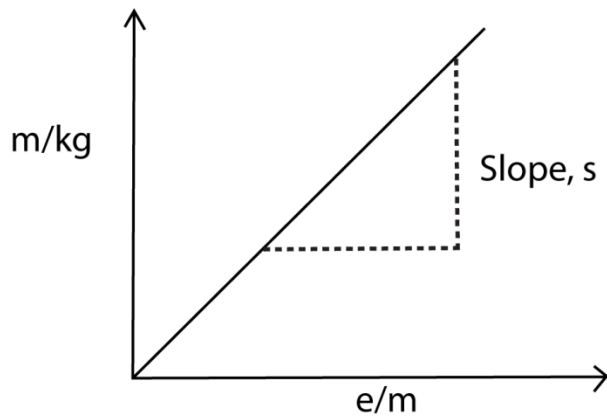

Young's modulus, $Y = \frac{gL}{A}$

- (d) Explain the term plastic deformation in metals (02marks)

During plastic deformation, some crystal planes slide over each other. The movement of dislocation takes place and on removing the stress, the original shape and size are not recovered due to energy loss in form of heat.

23. (a) Define work and energy (02marks)

Work is a product of force and distance moved in the direction of force.

Energy is the ability to do work

- (b) Explain whether a person carrying a bucket of water does any work on the bucket while walking on a levelled road. (03marks)

There is no net force on the bucket in horizontal direction. The only force he exerts on the bucket is against the weight mg of the bucket perpendicular to the direction of motion.

From work = $F\cos 90 = 0$, there is no work done on the bucket

- (c) A pump discharges water through a nozzle of diameter 4.5cm with speed of 62ms^{-1} into a tank 16m above the intake.

- (i) Calculate the work done per second by the pump in raising the water if the pump is ideal. (04marks)

$$\begin{aligned} \text{Total work done per second} &= \text{P.E} + \text{K.E} \\ &= mgh + \frac{1}{2} mv^2 \\ &= 10^3\pi(2.25 \times 10^{-2})^2 \times 62(9.81 \times 16 + \frac{1}{2} \times 62^2) \\ &= 2.05 \times 10^5 \text{Js}^{-1} \end{aligned}$$

- (ii) Find the power wasted if the efficiency of the pump is 73% (02marks)

$$\text{Efficiency} = \frac{P_{out}}{P_{in}} \times 100 = 73$$

$$P_{in} = \frac{2.05 \times 10^5}{73} = 2.81 \times 10^6 \text{W}$$

$$\text{Power lost} = P_{in} - P_{out} = 2.81 \times 10^6 - 2.05 \times 10^5 = 7.6 \times 10^4 \text{W}$$

- (iii) Account for the power loss in (c)(ii) (02marks)

Power is lost in overcoming friction and some is converted into sound and heat

(d) (i) State work-energy theorem. (01mark)

It states that work done by the net force acting on a body is equal to the change in its kinetic energy.

(ii) Prove the work-energy theorem for a body moving with constant acceleration. (03marks)

From $v^2 = u^2 + 2as$

$$s = \frac{v^2 - u^2}{2a}$$

Work done = $F \times s$ but $F = ma$

$$\begin{aligned} &= ma \left(\frac{v^2 - u^2}{2a} \right) \\ &= \frac{1}{2}mv^2 - \frac{1}{2}mu^2 \end{aligned}$$

Therefore work done = change in kinetic energy

(e) Explain briefly what is meant by internal energy of a substance. (03marks)

The internal energy of a body or a substance is the total sum of kinetic energy and potential energy of the particles of a substance is the internal energy of a substance

24. (a) Define coefficient of viscosity and state its units. (02marks)

Coefficient of viscosity is the frictional force on unit area of a liquid in a region of unit velocity gradient. Units Pas or Nsm^{-2}

(b) Explain the origin of viscosity in air and account for the effect of temperature on it. (05marks)

In air, molecules are further apart and have negligible intermolecular forces. Therefore the molecules move randomly colliding with one another and continuously transferring momentum to the neighbouring layers. The transfer of momentum constitute viscosity of air. When the temperature increases the molecules move faster, their kinetic energy increases and make more frequent collision. This increases the transfer of momentum and lead to increase in viscosity.

(c) Describe, stating the necessary precautions an experiment to measure the coefficient of viscosity of a liquid using Stroke's law. (07marks)

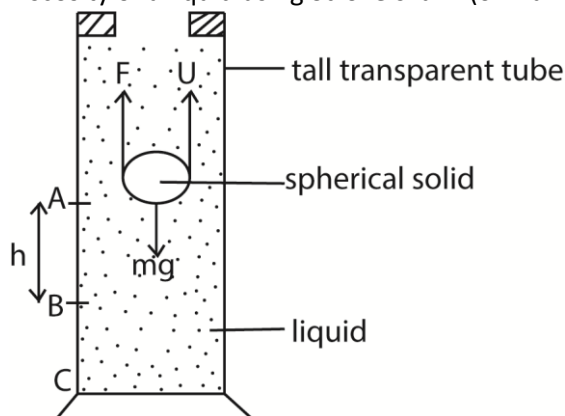

- A liquid of known density, ρ , is put in a tall transparent glass with reference marks A and B, h metres apart
- A spherical solid of radius a and density, σ , is dropped into the liquid and time t taken to drop from A to B is determined.
- Terminal velocity, $v_0 = \frac{h}{t}$

$$\text{The coefficient viscosity, } \eta = \frac{2r^2(\sigma - \rho)g}{9v_0}$$

Assumptions

The spherical solid moves with terminal velocity by the time it reaches A

Precautions

- The glass tube should be very wide compared to the diameter of the ball.
- The point C should be far away from the top of the tube
- Temperature is constant

(d) A steel ball bearing of diameter 8.0mm falls steadily through oil and covers a vertical height of 20.0cm in 0.56s. If the density of steel is 7800kgm^{-3} and that of oil is 900kgm^{-3} , calculate the

(i) up thrust on the ball (03marks)

$$U = \frac{4}{3}\pi r^3 \rho g = \frac{4}{3}\pi \times (4 \times 10^{-3})^3 \times 900 \times 9.81 = 2.37 \times 10^{-3}\text{N}$$

(ii) viscosity of the oil (03marks)

$$\text{From } \eta = \frac{2r^2(\sigma - \rho)g}{9v_0}$$

$$\eta = \frac{2(4 \times 10^{-3})^2 \times 9.81(7800 - 900)}{9 \times 0.357} = 0.674\text{Nsm}^{-2}$$

25. (a) Using the molecular theory, explain the laws of friction between solid surfaces. (06marks)

- For any two solid surfaces in contact, there are small humps and hollows that form contact points.
- Therefore, the actual area of contact is indeed small which creates very high pressure at the points of contact.
- This pushes the molecules very close that the forces of attraction between them welds the surfaces at these points.
- Thus, a force that opposes motion in any direction is created.

(b) With the aid of a labelled diagram, describe how the coefficient of static friction for an interface between a rectangular block of wood and a plane surface can be determined. (06marks)

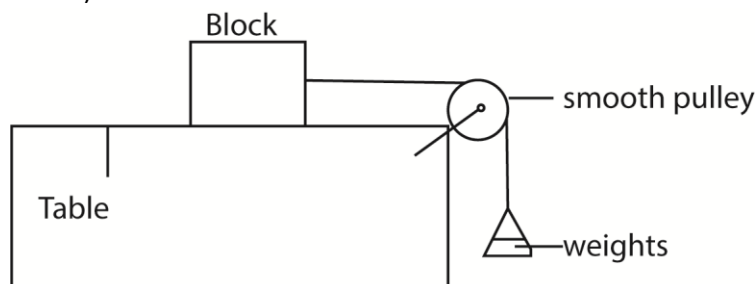

- A block of mass m is placed on a flat table and connected to a scale pan as shown in the diagram above.

- Small weights are added in bits on to the scale pan until the block just starts to move. The total weight of the scale pan and weights added is obtained, W_f .
- The coefficient of static friction, $\mu = \frac{W_f}{m.g}$

Alternative method

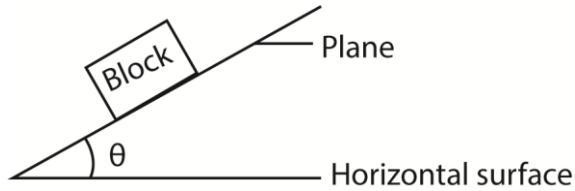

- A block is placed on horizontal plane. The plane is tilted gently until the block just start to slide
- The angle of tilt θ is measured
- The coefficient of static friction, $\mu = \tan\theta$

(c) The diagram below shows three masses connected by inextensible strings which pass over smooth pulleys. The coefficient of friction between the table and the 12.0kg mass is 0.25.

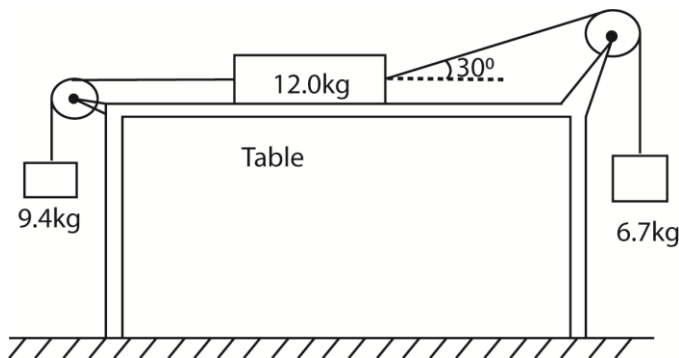

If the system is released from rest, determine the
(i) Acceleration of the 12.0kg mass (05marks)

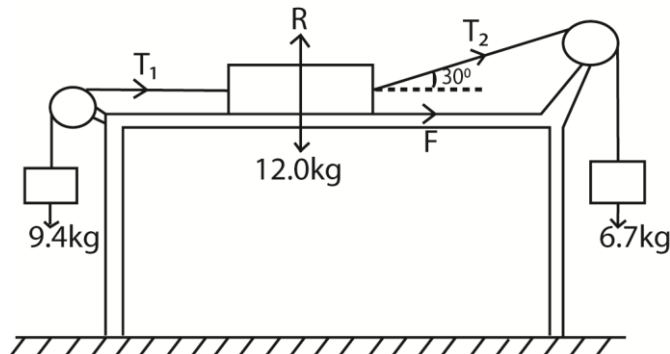

$$9.4g - T_1 = 9.4a \dots\dots\dots (i)$$

$$T_1 - T_2 \cos 30^\circ - F = 12a \dots\dots\dots (ii)$$

$$T_2 - 6.7g = 6.7a \dots\dots\dots (iii)$$

$$F = \mu R = 0.25(12g - T_2 \times 0.5) = 3g - \frac{T_2}{8}$$

$$a = 0.53 \text{ms}^{-2}$$

(ii) Tension in each string (03marks)

$$T_2 = 6.7a + 6.7g = 6.7(0.53 + 9.81) = 69.3\text{N}$$

$$T_1 = 9.4g - 9.4a = 9.4(9.81 - 0.53) = 87.2\text{N}$$

26. (a) Define terminal velocity (01mark)

Terminal velocity is the maximum velocity attained by a body falling through a viscous fluid.

(b) Explain laminar flow and turbulent flow (03marks)

Laminar flow is the type of flow where equidistant layers of fluid from the axis of flow have the same velocity flow lines are parallel to the axis of flow and the flow is orderly.

Turbulent flow is the type of flow where equidistant layers of a fluid from the axis of flow have varied velocities. The flow lines are not parallel and the flow is disorderly.

(c) Describe an experiment to measure the coefficient of viscosity of water using Ponselle's formula. (07marks)

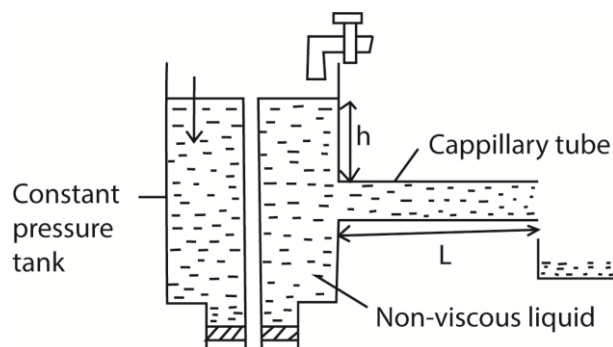

- the liquid of density, ρ , passes slowly from a constant head tank through a capillary tube of length, l and radius r .
- for a height, h , of the tube, the volume V is collect in time t .
- the flow rate $R = \frac{V}{t}$ is calculated
- the experiment is repeated for different value of V and h .
- a graph of R against h is plotted and slope S is obtained

$$\text{For steady flow, } S = \frac{\pi r^4 P}{8\eta l}$$

$$\text{But } P = h\rho g$$

$$r = \frac{d}{2}$$

$$S = \frac{\pi \left(\frac{d}{2}\right)^4 P}{8\eta l}$$

$$\eta = \frac{\pi \left(\frac{d}{2}\right)^4 h\rho g}{8Sl}$$

(d) (i) State Bernoulli's principle (01 mark)

For non-viscous incompressible fluid flowing steadily, the sun of pressure plus kinetic energy per unit volume Plus potential energy per unit volume is constant.

(ii) Explain why a person standing near a railway line is sucked towards the railway line when a fast moving train passes. (03marks)

Between the man and the train, the velocity of air is increased due to the motion of the train resulting in a decrease in pressure according to Bernoulli's Principle. Behind the man, the flow velocity is lower and pressure is higher. This results in a resultant force towards the train, hence the man is sucked in

- (e) A horizontal pipe of cross sectional area 0.4m^2 , tapers to a cross section area of 0.2m^2 . The pressure at the large section of the pipe is $8.0 \times 10^4\text{Nm}^{-2}$ and the velocity of water through the pipe is 11.2ms^{-1} . If the atmospheric pressure is $1.01 \times 10^5\text{Nm}^{-2}$, find the pressure at the small section of the pipe. (05marks)

$$A_1V_1 = A_2V_2$$

$$0.4 \times 11.2 = 0.2 \times V_2$$

$$V_2 = 24.4\text{ms}^{-1}$$

$$P_1 + \frac{1}{2}\rho V_1^2 + \rho gh_1 = P_2 + \frac{1}{2}\rho V_2^2 + \rho gh_2$$

Since $h_1 = h_2$

$$P_1 + \frac{1}{2}\rho V_1^2 = P_2 + \frac{1}{2}\rho V_2^2$$

$$8.0 \times 10^4 + \frac{1}{2} \times 10^3 \times 11.2^2 = P_2 + \frac{1}{2} \times 10^3 \times 24.4^2$$

$$P_2 = 7.784 \times 10^4\text{Pa}$$

27. (a) (i) State the law of conservation of linear momentum (01mark)

If no external force acts on a system of colliding objects, the total momentum of the objects in a given direction before collision is equal to the total momentum in the same direction after collision

- (ii) A body explodes and produces two fragments of mass m and M . If the velocities of the fragments are u and v respectively. Show that the ratio of the kinetic energies of the fragments is

$$\frac{E_1}{E_2} = \frac{M}{m} \text{ where } E_1 \text{ is the kinetic energy of } m \text{ and } E_2 \text{ is the kinetic energy of } M.$$

$$E_1 = \frac{1}{2}mu^2 \text{ and } E_2 = \frac{1}{2}Mv^2$$

From the principle of conservation of linear momentum $mu = -Mv$

$$v = \frac{-mu}{M}$$

$$E_2 = \frac{1}{2}M \left(\frac{-mu}{M}\right)^2 = \frac{1}{2}M \times \frac{m^2u^2}{M^2} = \frac{1}{2}mu^2 \times \frac{m}{M} = E_1 \frac{m}{M}$$

$$\frac{E_1}{E_2} = \frac{M}{m}$$

- (b) Show that the centripetal acceleration of an object moving with constant velocity, v , in a circle of radius, r is $\frac{v^2}{r}$. (04marks)

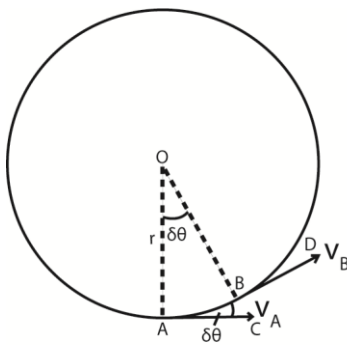

(i)

Acceleration in circle

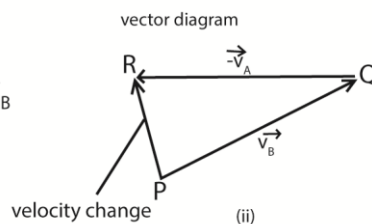

(ii)

The velocity change from A to B = $v_B - v_A$ or $v_B + (-v_A)$.

In figure 2(ii) above, PQ represents v_B in magnitude (v) and direction BD; QR represents $-v_A$ in magnitude (v) and direction (CA).

Velocity change = $v_B + (-v_A) = PR$

When δt is small, the angle AOB or $\delta\theta$ is small;

Also angle PQR equal to $\delta\theta$ is small

PR or acceleration then points toward O, the centres of the circle.

$$a = \frac{\text{velocity change}}{\text{time}} = \frac{PR}{\delta t} = \frac{v\delta\theta}{\delta t}$$

but $\frac{\delta\theta}{\delta t} = \omega$ and $v = r\omega$

$$a = r\omega \times \omega = r\omega^2 \text{ but } \omega = \frac{v}{r}$$

$$\therefore a = \frac{v^2}{r}$$

- (c) A car of mass 1000kg moves round a banked track at constant speed of 108kmh⁻¹. Assuming the total reaction at the wheels is normal to the track, and the radius of curvature of the truck is 100m, calculate the:

- (i) angle of inclination of the track to the horizontal (04marks)

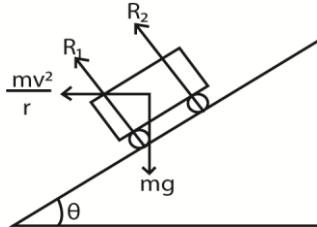

$$Fr\theta m \tan\theta = \frac{v^2}{rg}$$

$$v = 108\text{kmh}^{-1} = \frac{108 \times 1000}{60 \times 60} = 30\text{ms}^{-1}$$

$$\tan\theta = \frac{30^2}{100 \times 9.81}$$

$$\theta = 42.5^\circ$$

- (ii) reaction at the wheels (02marks)

$$\text{From } (R_1 + R_2) \sin\theta = \frac{mv^2}{r}$$

$$\Rightarrow R_1 + R_2 = \frac{mv^2}{r \sin\theta} = \frac{1000 \times 30^2}{100 \sin 42.5^\circ} = 1.33 \times 10^4 \text{N}$$

- (d) (i) Define uniformly accelerated motion (01mark)

Uniformly accelerated motion is where velocity changes by the same amount in the same time interval

- (ii) A train starts from rest at station A and accelerates at 1.25ms^{-2} until it reaches a speed of 20ms^{-1} . It then travels at this steady speed for a distance of 1.56km and then decelerates at 2ms^{-2} to come to rest at station B. Find the distance from A to B. (04marks)

For accelerated motion using $v^2 = u^2 + 2as$

$$20^2 = 0^2 + 2(1.25)s$$

$$s = 160\text{m}$$

For deceleration:

$$0 = 20^2 - 2 \times 2 \times s$$

$$s = 100\text{m}$$

$$\text{Total distance} = 160 + 1560 + 100 = 1820\text{m}$$

28. (a)(i) State Kepler's laws of planetary motion. (03marks)

- Planets describe ellipses about the sun as one focus
- The imaginary line joining the sun and planet sweeps out equal areas in equal time intervals
- The square of the periodic time of revolution of planets about the sun are proportional to the cubes of their mean distance from the sun

- (ii) Estimate the mass of the sun, if the orbit of the earth around the sun is circular. (04marks)

$$M = \frac{4\pi^2 r^3}{GT^2} = \frac{4\pi^2 \times (1.5 \times 10^{11})^3}{6.67 \times 10^{-11} \times (365 \times 24 \times 60 \times 60)} = 2.0 \times 10^{30}\text{kg}$$

- (b) Explain Brownian motion (03marks)

Continuous random and haphazard (zig-zag) motion of fluid particles caused by repeated collision of particles exerting a resultant force on each other which changes in magnitude and direction.

- (c) Explain the energy changes which occur when a pendulum is set into motion. (03marks)

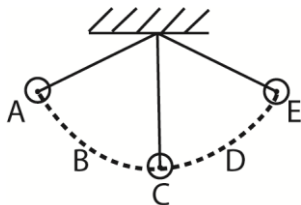

Potential energy at A → Kinetic + potential energy at B → kinetic at C → Kinetic + potential energy at D → potential energy at E

- (d) A simple pendulum of length 1m has a bob of mass 100g . It is displaced from mean position A to position B so that the string makes an angle of 45° with the vertical. Calculate the

(i) maximum potential energy of the bob. (03marks)

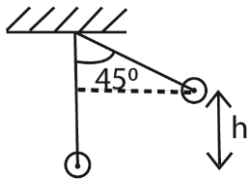

$$h = 1 - \cos 45 = 0.293$$

$$P.E = mgh = 0.1 \times 9.81 \times 0.293 = 0.287\text{J}$$

(ii) velocity of the bob when the string makes an angle of 30° with the vertical. [Neglect air resistance]

$$\text{Height of the ball when the string makes } 30^\circ = 1 - \cos 30 = 0.134$$

$$\text{Potential energy at this point} = mgh = 0.1 \times 9.81 \times 0.134 = 0.122\text{J}$$

$$\text{Kinetic energy} = \text{change in potential energy} = 0.287 - 0.122 = 0.165\text{J}$$

Let the velocity be v

$$\Rightarrow \frac{1}{2} \times 0.1 \times v^2 = 0.165$$

$$v = 1.8\text{ms}^{-1}$$

29. (a) State Hooke's law. (01mark)

Hooke's law states that extension is proportional to the load provided the proportionality limit is not exceeded.

(b) A copper wire is stretched until it breaks.

(i) Sketch a stress-strain graph for the wire and explain the main features of the graph. (04marks)

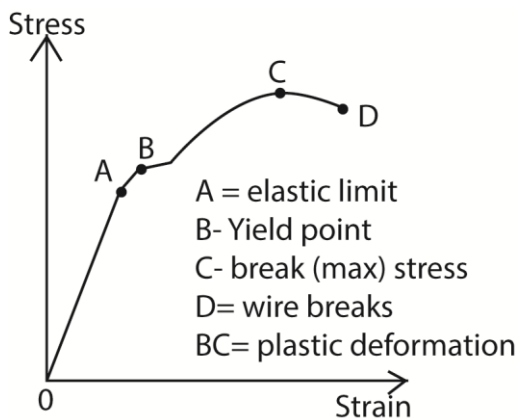

- OA – stress is proportional to strain and the material regains its length
- AB - stress is not proportional to strain but the material regains its length
- Beyond B the material becomes permanently stretched
- CD the material undergoes plastic deformation
- Beyond D the material breaks

(ii) Explain what happens to the energy used to stretch the wire at each stage. (04marks)

- During elastic deformation, atoms are slightly displaced from equilibrium position. When the load is applied to the wire, energy used to stretch wire becomes elastic potential energy
- When the wire is stretched beyond elastic limit, permanent displacement of atoms occurs. The energy is used to break some interatomic bond and some is released as heat.
- At the breaking point, energy is used to break the interatomic bonds.

(iii) Derive the expression for the work done to stretch a spring of force constant, k, by a distance, x. (03marks)

$$dw = Fdx$$

$$\text{Work done} = \int_0^e Fdx$$

$$\text{But } F = kx$$

$$\therefore W = \int_0^e kx dx = \frac{1}{2} ke^2$$

(c)(i) Define Young's Modulus. (01mark)

Young's Modulus is the ratio of tensile stress to tensile strain

(ii) Two identical steel bars A and B of radius 2.0mm are suspended from the ceiling. A mass of 2.0kg is attached to the free end of bar A. Calculate the temperature to which B should be raised so that the bars are again equal in length.

[Young's Modulus of steel = $1.0 \times 10^{11} \text{Nm}^{-2}$]

[Linear expansivity of steel = $1.2 \times 10^{-5} \text{K}^{-1}$] (05mark)

$$e = \frac{Fl}{AE}, \text{ also } e = \alpha \Delta\theta \text{ where } \Delta\theta \text{ is temperature change}$$

$$\Rightarrow \Delta\theta = \frac{F}{AE\alpha} = \frac{2 \times 9.81}{\pi(2.0 \times 10^{-3})^2 \times 1.0 \times 10^{11} \times 1.2 \times 10^{-5}} = 1.4 \text{K}$$

(d) Why does an iron roof make cracking sound at night? (02marks)

During the day, the roof is heated, it expands and buckles since it is fixed. At night, the roof contracts due to fall in temperature. As it straightens again sound is produced.

30. (a) Define the following terms as applied to oscillatory motion

(i) Amplitude (01mark)

Amplitude is the maximum displacement of a particle from equilibrium or mean position

(ii) Period (01mark)

Period is the time taken to make 1 cycle.

(b) State four characteristics of simple harmonic motion. (02marks)

- A periodic motion
- Acceleration is proportional to displacement
- Acceleration is directed towards a fixed point
- Mechanical energy is conserved.

(c) A mass, m is suspended from a rigid support by a straight string of length L. The mass is pulled aside so that the string makes an angle, θ , with the vertical and then released.

(i) Show that the mass executes simple harmonic motion with a period $T = 2\pi \sqrt{\frac{L}{g}}$.

Suppose a body of mass, m, attached to a string is displaced through a small angle θ

and then released. The resultant force on the body towards O is $mg\sin\theta$.

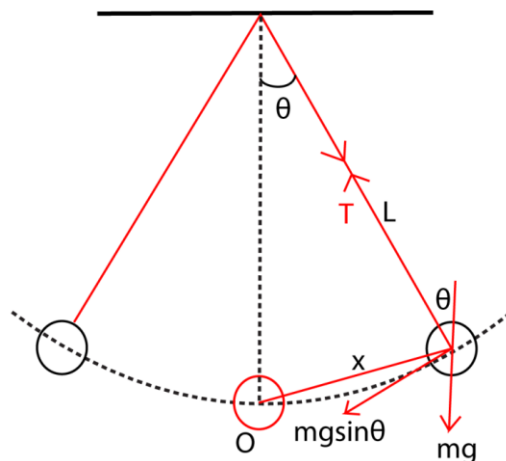

By Newton's 2nd law

$$ma = -mg\sin\theta$$

$$a = -g\sin\theta$$

If θ is small and measured in radians $\theta \approx \sin\theta = \frac{x}{L}$

$$a = g\frac{x}{L}$$

But $a = -\omega^2x$

$$\omega = \sqrt{\frac{L}{g}}$$

$$T = \frac{2\pi}{\omega}$$

$$T = 2\pi\sqrt{\frac{L}{g}}$$

(ii) Explain why this mass comes to a stop after a short time. (02marks)

The mass comes to a stop due to the presence of dissipative forces leading to loss of energy and amplitude reduces with time.

(d) A piston in a car engine performs a simple harmonic motion of frequency 12.5Hz. If the mass of the piston is 0.50kg and its amplitude of vibration is 45mm, find the maximum force on the piston. (03marks)

$$\text{Maximum force} = m\omega^2A \text{ but } \omega = 2\pi f$$

$$\text{Maximum force, } F = 0.5 \times (2\pi \times 12.5)^2 \times 0.045 = 138.8\text{N}$$

(e) Describe an experiment to determine the acceleration due to gravity, g , using a spiral spring, of known constant. (06marks)

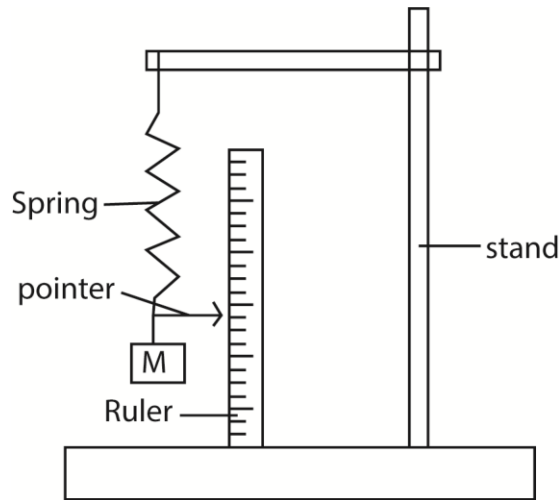

- Clamp the spring on a retort stand
- Fix a horizontal pin at free end of the spring to act as a pointer.
- Place a vertical meter rule next the pointer and note the initial pointer position, P_1 .
- Suspend a known mass, M , to the free end of the spring, note and record the new position of the pointer, P_2 .
- Calculate extension, $e = P_2 - P_1$.
- Find the extensions for different masses
- Plot a graph of e against M
- Calculate the slope, S of the graph
- Calculate the acceleration due to gravity, $g = kS$ ($k = \text{force constant}$)

31. (a) Explain what is meant by centripetal force. (02marks)

Centripetal force is the force that keeps a body moving in a circular path. It's directed towards the centre of the path.

(b)(i) Derive an expression for centripetal force acting on a body of mass, M , moving in a circular path of radius, r . (06marks)

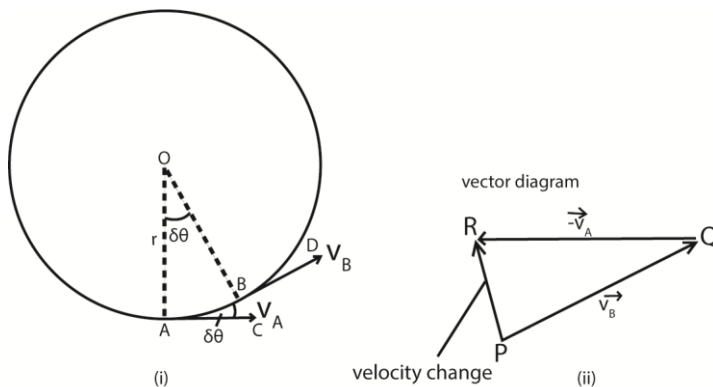

Acceleration in cycle

The velocity change from A to B = $v_B - v_A$ or $v_B + (-v_A)$.

In figure 2(ii) above, PQ represents v_B in magnitude (v) and direction BD; QR represents $-v_A$ in magnitude (v) and direction (CA).

Velocity change = $v_B + (-v_A) = PR$

When δt is small, the angle AOB or $\delta\theta$ is small;

Also angle PQR equal to $\delta\theta$ is small

PR or acceleration then points toward O, the centres of the circle.

$$a = \frac{\text{velocity change}}{\text{time}} = \frac{PR}{\delta t} = \frac{v\delta\theta}{\delta t}$$

$$\text{but } \frac{\delta\theta}{\delta t} = \omega \text{ and } v = r\omega$$

$$a = r\omega \times \omega = r\omega^2 \text{ but } \omega = \frac{v}{r}$$

$$- a = \frac{v^2}{r}$$

$$\text{Centripetal force} = ma = \frac{mv^2}{r} = mr\omega^2$$

- (ii) A body moving in a circular path of radius 0.5m makes 40 revolutions per second. Find the centripetal force if the mass is 1kg (03marks)

$$F = mr\omega^2 \text{ but } \omega = 2\pi f$$

$$= 1 \times 0.5 \times (2\pi \times 40)^2 = 1.36 \times 10^4 \text{N}$$

- (c) Explain the following

- (i) A mass attached to a string rotating at constant speed in a horizontal circle will fly off at a tangent of the string breaks. (02marks)

If the string breaks, the mass will not have any centripetal force and will continue in a straight line along the tangent.

- (ii) A cosmonaut in a satellite which is in a free circular orbit around the earth experiences the sensation of weightlessness even though there is influence of gravitational field on earth. (03marks)

The sensation of weight is caused by the reaction of the floor on a person. In orbit, the cosmonaut and the floor have the same acceleration towards the centre of the earth.

The floor exerts no supporting force on the cosmonaut. (i.e. the reaction, $R = 0$)

- (d) (i) Derive an expression for maximum horizontal distance travelled by a projectile in terms of the initial speed, u , and the angle of projection, θ , to the horizontal. (02marks)

$$\text{Horizontally, } x = ut\cos\theta$$

$$\text{Vertically, } y = utsin\theta - \frac{1}{2}gt^2$$

$$\text{But } y = 0; t = \frac{2usin\theta}{g}$$

$$\therefore \text{Range} = \frac{2u^2sin\theta cos\theta}{g} = \frac{u^2sin2\theta}{g}$$

- (ii) Sketch a graph to show the relationship between kinetic energy and height above the ground in a projectile. (02marks)

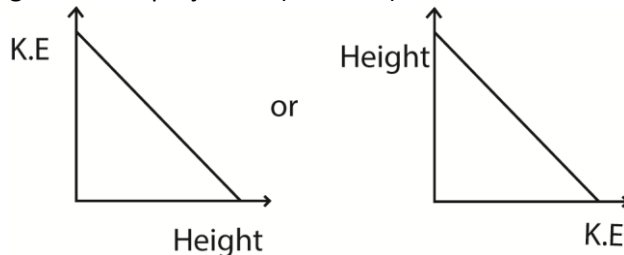

32. (a)(i) What is meant by the following terms, steady flow and viscosity? (02marks)

- Steady flow is the flow where the velocity of the liquid past any given point is constant.

- Viscosity is the friction between layers of a fluid.

(ii) Explain the effect of increase in temperature on viscosity of a liquid. (03marks)

- When temperature rises, the molecular separation of liquid molecules increases and the intermolecular forces decrease. The resistance to flow then decreases hence a decrease in viscosity.

(b) (i) Show that the pressure, P , exerted at a depth, h , below the free surface of a liquid of density, ρ , is given by $P = h\rho g$. (03marks)

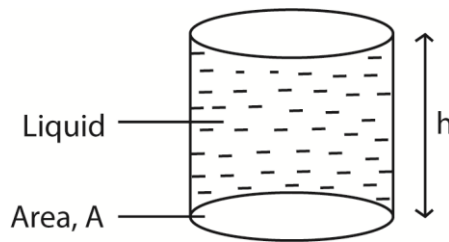

Weight of a liquid above $A = mg$

But $= Ah\rho$

\Rightarrow Weight = Force = $Ah\rho g$

$$\text{Pressure} = \frac{F}{A} = \frac{Ah\rho g}{A} = h\rho g$$

(ii) Define relative density. (01mark)

Relative density is the ratio of the mass of any volume of a substance to the mass of an equal volume of water

(iii) A U-tube whose ends are open to atmosphere, contains water and oil as shown in the figure below

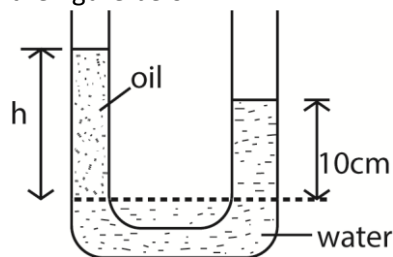

Given the density of oil is 800kgm^{-3} , find the value of h .

Pressure of oil and that of water at the dotted line are equal, if the density of oil = σ and that of water = ρ , then

$$h\sigma g = 0.1\rho g$$

$$h = \frac{0.1\rho}{\sigma} = \frac{0.1 \times 1000}{800} = 0.125\text{m} = 12.5\text{cm}$$

(c) A metal ball of diameter 10mm is timed as it falls through oil at a steady speed. It takes 0.5s to fall through a vertical distance of 0.3m. Assuming that the density of metal is 7500kgm^{-3} and that of oil is 900kgm^{-3} , find

(i) the weight of the ball (02marks)

Weight = volume x density of the ball x acceleration due to gravity

$$= \frac{4}{3}\pi r^3 \sigma g = \frac{4}{3}\pi (5 \times 10^{-3})^3 \times 7500 \times 9.81 = 3.85 \times 10^{-2} \text{N}$$

(ii) the up thrust on the ball (02marks)

Up thrust = volume of water displaced x density of water x acceleration due to gravity

$$= \frac{4}{3}\pi r^3 \rho g = \frac{4}{3}\pi (5 \times 10^{-3})^3 \times 1000 \times 9.81 = 4.62 \times 10^{-3} \text{N}$$

(iii) the coefficient of viscosity of the oil (03marks)

$$W = U + F$$

$$mg = U + 6\pi r \eta v_0$$

$$\text{But } v_0 = \frac{0.30}{0.6} = 0.6 \text{ms}^{-1}$$

$$\eta = \frac{mg - U}{6\pi r v_0} = \frac{3.85 \times 10^{-2} - 4.62 \times 10^{-3}}{6\pi \times (5 \times 10^{-3}) \times 0.6} = 0.6 \text{Pa (or } 0.6 \text{Nm}^{-2}\text{s)}$$

[Assume the viscous force = $6\pi r \eta v_0$ where η is the coefficient of viscosity, r is the radius of the ball, v_0 is the terminal velocity]

33. (a) Define the following terms

(i) Uniform acceleration (01mark)

Uniform acceleration is a constant rate of change of velocity

(ii) Angular velocity (01mark)

Angular velocity is the rate of change of angular displacement

(b) (i) What is meant by banking a track? (01mark)

Banking of roads is defined as the phenomenon in which the edges are raised for the curved roads above the inner edge to provide the necessary centripetal force to the vehicles so that they take a safe turn.

(ii) Derive an expression for the angle of banking θ for a car of mass, m , moving at speed, v , round a banked track of radius, r . (04marks)

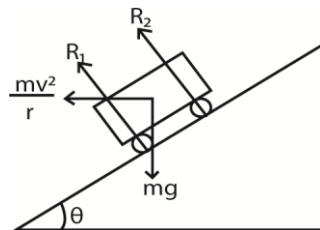

$$\text{Resolving horizontally: } (R_1 + R_2)\sin\theta = \frac{mv^2}{r} \dots\dots\dots (i)$$

$$\text{Resolving vertically: } (R_1 + R_2)\cos\theta = mg \dots\dots\dots (ii)$$

Eqn. (i) and Eqn. (ii);

$$\tan \theta = \frac{v^2}{rg}$$

$$\theta = \tan^{-1}\left(\frac{v^2}{rg}\right)$$

(c) A bob of mass, m is tied to an inelastic thread of length, L , and whirled with constant speed in a vertical circle

(i) With the aid of a sketch diagram, explain the variation of tension in the string along the circle. (05 marks)

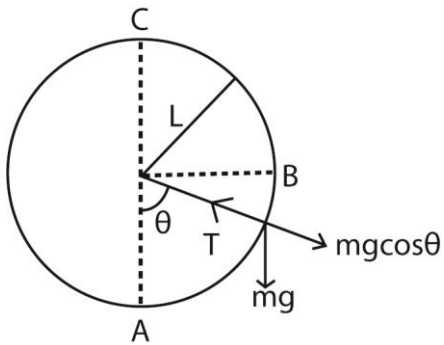

At A, $\theta = 0$

$$\Rightarrow T = \frac{mv^2}{L} + mg$$

At B, $\theta = 90^\circ$

$$\Rightarrow T = \frac{mv^2}{L}$$

At C, $\theta = 180^\circ$

$$\Rightarrow T = \frac{mv^2}{L} - mg$$

(ii) If the string breaks at one point along the circle, state the most likely position and explain the subsequent motion of the bob.

The string breaks at the lowest point, A of the circle because tension the string is highest. Motion is tangential to the circle and when the string breaks, the bob follows a parabolic path.

(d) A body of mass 15kg is moved from earth's surface to a point 1.8×10^6 m above the earth. If the radius of the earth is 6.4×10^6 m and the mass of the earth is 6.0×10^{24} kg; calculate the work done in taking the body to that point (06marks)

$$\text{On earth, P.E}_1 = \frac{-GmM}{R_s}$$

$$\text{Above the earth P.E}_2 = \frac{-GmM}{r}, r = ((6.4 + 1.8) \times 10^6) = 8.2 \times 10^6 \text{m}$$

$$\text{Work done} = GmM\left(\frac{1}{R_s} - \frac{1}{r}\right)$$

$$= 6.67 \times 10^{-11} \times 6.0 \times 10^{24} \times 15\left(\frac{1}{6.4 \times 10^6} - \frac{1}{8.2 \times 10^6}\right)$$

$$= 2.06 \times 10^8 \text{J}$$

34. (a) State Newton's laws of motion. (03marks)

- A body continues in its state of rest or uniform motion in a straight line unless acted upon by an external force
- The rate of change of momentum of a body is directly proportional to applied force and takes place in the direction of the force
- For every action, there is an equal and opposite reaction

(b) Use Newton's laws of motion to show that when two bodies collide their momentum is conserved. (04marks)

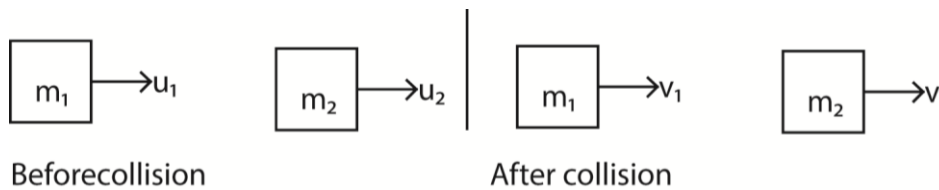

During collision, each body exerts a force of impact on each other according to Newton's second law of motion.

Let I be the impulse on A, then the impulse on B = -I.

$$I = M_1 v_1 - m_1 u_1 \dots\dots\dots (i)$$

$$-I = m_2 v_2 - m_2 u_2 \dots\dots\dots (ii)$$

Equation (i) + equation (ii)

$$0 = M_1 v_1 - m_1 u_1 + m_2 v_2 - m_2 u_2$$

$$m_1 u_1 + m_2 u_2 = m_1 v_1 + m_2 v_2$$

(c) Two balls P and Q travelling in the same line in opposite directions with speeds of 6ms^{-1} and 15ms^{-1} respectively make a perfect collision. If the masses of P and Q are 8kg and 5kg respectively, find the

(i) final velocity of P, (04marks)

$$m_1 u_1 + m_2 u_2 = (m_1 + m_2) v$$

$$-8 \times 6 + 5 \times 15 = (8 + 5) v$$

$v = - 2.08\text{ms}^{-1}$ in the same direction as that of Q

(ii) change in kinetic energy. (04marks)

Change in kinetic energy = initial K.E – Final K.E

$$= \left(\frac{1}{2} \times 8 \times 6^2 - \frac{1}{2} \times 5 \times 15^2 \right) - \frac{1}{2} \times 13 \times 2.08^2$$

$$= 678.38\text{J}$$

(d) (i) What is an impulse of a force? (01marks)

An impulse is a product of force and time of action of force

(ii) Explain why a long jumper should normally land on sand. (04marks)

By landing on sand, the time take to come to rest is increased and hence the rate of change of momentum is reduced. Therefore the force on the jumpers legs is reduced thus less pain in the legs.

35. (a) (i) What is meant by viscosity. (01mark)

Viscosity is the frictional force per unit area of a liquid where the velocity gradient is unity.

- (ii) Explain the effect of temperature on viscosity of a liquid. (03marks)

Increase in temperature of a liquid increases the separation between the molecules and reduce the intermolecular attraction leading to a decrease in viscosity.

- (b) Derive an expression for terminal velocity of a sphere of radius, a , falling in a liquid of viscosity, η . (04marks)

At terminal velocity, $mg = U + F_v$

$$\Rightarrow \frac{4}{3}\pi a^3 \sigma g = \frac{4}{3}\pi a^3 \rho g - 6\pi a \eta v_0$$

$$v_0 = \frac{2ga^2(\sigma - \rho)}{9\eta} \text{ where;}$$

σ = density of the sphere

ρ = density of the liquid

η = viscosity of the fluid

g = acceleration due to gravity

- (c) Explain why velocity of a liquid at a wide part of a tube is less than that at a narrow part. (02marks)

Volume flow per second is constant, so by the equation of continuity $AV = \text{constant}$, the velocity is inversely proportional to cross section area.

- (d) A solid weighs 237.5g in air and 12.5g when totally immersed in a fluid of density $9.0 \times 10^2 \text{kgm}^{-3}$. Calculate the density of the liquid in which the sold would float with one fifth of its volume exposed above the liquid surface.

$$\text{Up thrust} = \frac{(237.5 - 12.5)}{1000} = 0.225 \text{kg}$$

$$\text{Volume} = \frac{0.225}{900}$$

$$\text{Volume the liquid displaced} = \frac{4}{5} \times \frac{0.225}{900}$$

$$\text{The } \frac{4}{5} \times \frac{0.225}{900} \rho = 237.5$$

$$\rho = 1187.5 \text{kgm}^{-3}$$

- (e) Describe an experiment to measure the coefficient of static friction between a rectangular block of wood and a plane surface. (04marks)

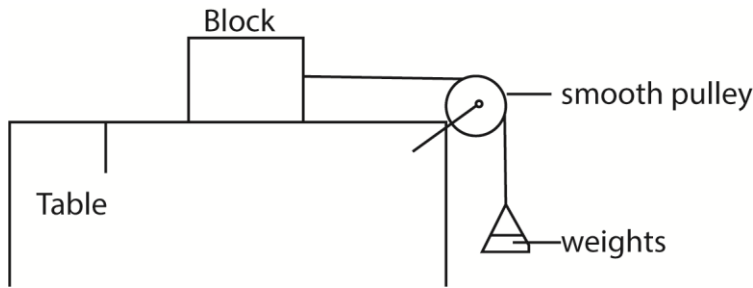

- A block of mass m is placed on a flat table and connected to a scale pan as shown in the diagram above.
- Small weights are added in bits on to the scale pan until the block just starts to move. The total weight of the scale pan and weights added is obtained, W_f .
- The coefficient of static friction, $\mu = \frac{W_f}{m.g}$

Alternative method

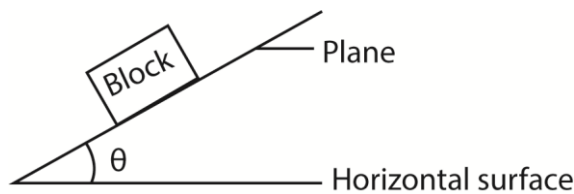

- A block is placed on horizontal plane. The plane is tilted gently until the block just start to slide
- The angle of tilt θ is measured
- The coefficient of static friction, $\mu = \tan\theta$

36. (a) (i) What is meant by simple harmonic motion? (01mark)

Simple harmonic motion is the periodic motion of a body whose acceleration is proportional to the displacement from a fixed point and directed towards the fixed point.

(ii) State two practical examples of simple harmonic motion. (01mark)

- Motion of pistons in an engine
- Motion of balance wheel of a pendulum clock

(iii) Using graphical illustrations, distinguish between under damped and critically damped oscillations (04marks)

(i) **Under damped oscillation**

These are oscillations in which the system experiences low resistance/dissipative forces such that it loses energy gradually and amplitude of oscillations decrease gradually until the system finally comes to rest.

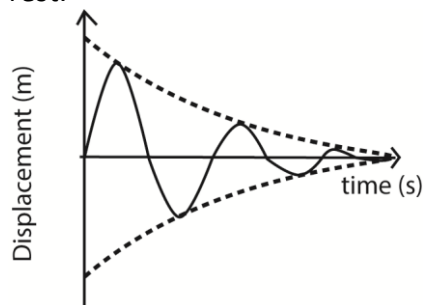

(ii) Critically damped

These are oscillation which occur when a system is displaced but does not oscillate and return to equilibrium position in the minimum possible time. The magnitude of resistive forces is such that they do not allow the system to vibrate past this equilibrium position.

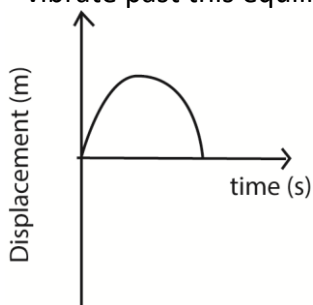

(b) (i) Describe an experiment to measure acceleration due to gravity using a spiral spring (06marks)

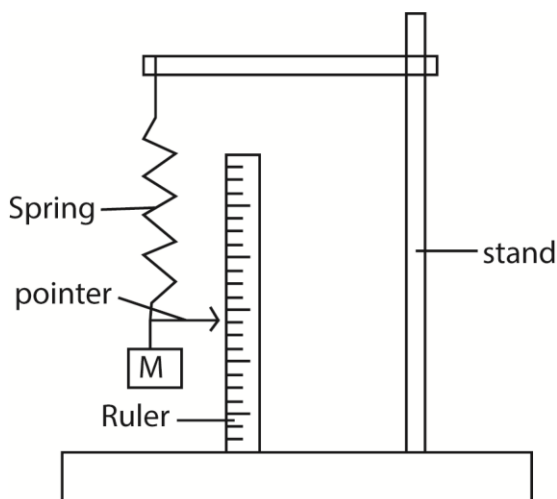

- Clamp the spring on a retort stand
- Fix a horizontal pin at free end of the spring to act as a pointer.
- Place a vertical meter rule next the pointer and note the initial pointer position, P_1 .
- Suspend a known mass, M , to the free end of the spring, note and record the new position of the pointer, P_2 .
- Calculate extension, $e = P_2 - P_1$.
- Find the extensions for different masses
- Plot a graph of e against M
- Calculate the slope, S of the graph
- Calculate the acceleration due to gravity, $g = kS$ (k = force constant)

(ii) State two limitations to the accuracy of the value obtained in (b)(i).

- Upthrust
- Accurate reading of initial and final pointer position

(c) A horizontal spring of force constant 200Nm^{-1} fixed at one end has a mass of 2kg attached to the free end and resting on a smooth horizontal surface. The mass is pulled through a distance of 40.0cm and released.

Calculate the

(i) Angular speed

$$\text{From } T = 2\pi \sqrt{\frac{m}{K}}$$

$$T = 2\pi \sqrt{\frac{2}{200}} = 0.628\text{s}$$

$$\text{But } \omega = \frac{2\pi}{T} = \frac{2\pi}{0.628} = 10\text{rad s}^{-1}$$

(ii) Maximum velocity attained by a vibrating body. (02marks)

$$v_{\text{max}} = \omega A$$

$$= 10 \times 4 \times 10^{-2} = 0.4\text{ms}^{-1}$$

(iii) Acceleration when the body is half way towards the centre from its initial position (02marks)

$$a = -\omega^2 x \quad \text{but } x = \frac{0.04}{2} = 0.02\text{m}$$

$$a = -10^2 \times 0.02 = 2\text{ms}^{-2}$$

37. (a) (i) State the law of conservation of linear momentum. (01mark)

The law of conservation of linear momentum states that for a system of interacting bodies, their total momentum remains constant provided there is no external force acting.

(ii) Use Newton's law to derive the law in (a) (i) (04marks)

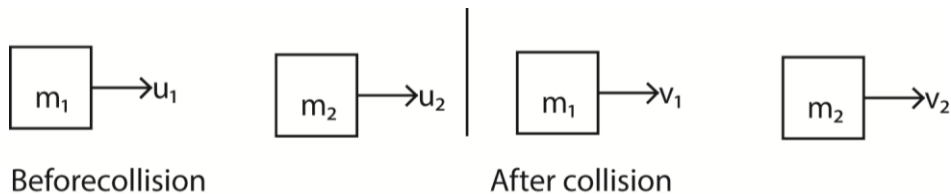

During collision, each body exerts a force of impact on each other according to Newton's second law of motion.

Let I be the impulse on A, then the impulse on B = -I.

$$I = M_1 v_1 - m_1 u_1 \dots\dots\dots (i)$$

$$-I = m_2 v_2 - m_2 u_2 \dots\dots\dots (ii)$$

Equation (i) + equation (ii)

$$0 = M_1 v_1 - m_1 u_1 + m_2 v_2 - m_2 u_2$$

$$m_1 u_1 + m_2 u_2 = m_1 v_1 + m_2 v_2$$

(b) Distinguish between elastic and inelastic collision (01mark)

- During an elastic collision, the interacting bodies separate after interaction and there is conservation of total kinetic energy.
- During inelastic collision, there is bouncing after interaction and there is loss of kinetic energy.

(c) An object X of mass M, moving with a velocity of 10ms^{-1} collides with a stationary object Y of equal mass. After collision, X moves with a speed u at an angle 30° to the initial direction, while Y, moves with a speed V at angle 90° to the new direction of X.

(i) Calculate the speeds U and V (05marks)

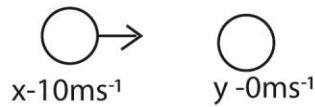

Before collision

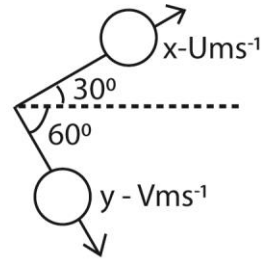

After collision

Applying the law of conservation of linear momentum in horizontal direction

$$m \times 10 = mU \cos 30^\circ + mV \cos 60^\circ$$

$$10 = U \frac{\sqrt{3}}{2} + \frac{V}{2} \dots\dots\dots (i)$$

Applying the law of conservation of linear momentum in vertical direction

$$m \times 0 = mU \sin 30^\circ - mV \sin 60^\circ$$

$$0 = \frac{U}{2} - V \frac{\sqrt{3}}{2}$$

$$U = V\sqrt{3} \dots\dots\dots (ii)$$

Eqn. (i) and Eqn. (ii)

$$U = 8.66 \text{ms}^{-1}$$

$$V = 5 \text{ms}^{-1}$$

(ii) Determine whether the collision is elastic or not. (03marks)

$$\text{Kinetic energy before} = \frac{1}{2} m \times 10^2 = 50 \text{mJ}$$

$$\text{Kinetic energy after collision} = \frac{1}{2} m \times 5^2 + \frac{1}{2} m \times 8.66^2 = 50 \text{mJ}$$

Since kinetic energy is conserved, the collision is elastic.

(d) (i) Define uniform acceleration. (01mark)

Uniform acceleration is the a constant rat of change of velocity

(ii) With the aid of a velocity-time graph, describe the motion of a body projected vertically upwards. (03marks)

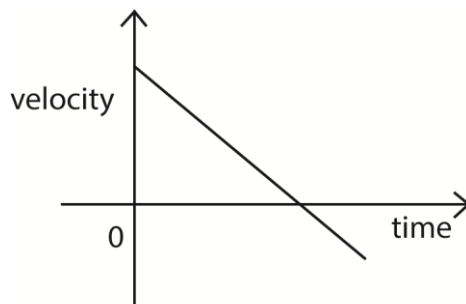

When a body is projected vertically upwards with velocity, V , it undergoes uniform retardation, g . At maximum height, the velocity becomes zero. It then accelerated uniformly downwards.

- (iii) Calculate the range of a projectile which is fired at an angle of 45° to the horizontal with a speed of 20ms^{-1} . (02marks)

$$R = \frac{u^2 \sin 2\theta}{g} = \frac{20^2 \times \sin 90}{9.81} = 40.77\text{m}$$

38. (a)(i) State Archimedes' principle. (01mark)

Archimedes' Principle state that when a body is wholly or partially immersed in a fluid, it experiences an up thrust equal to the weight of the fluid displaced.

- (ii) A solid weighs 20.0g in air, 15.0g in water and 16.0g in a liquid, R. Find the density of R (03marks)

Mass of displaced water = $20.0 - 15.0 = 5.0\text{g}$

Mass of liquid displaced = $20.0 - 16.0 = 4.0\text{g}$

Relative density of the liquid = $\frac{4}{5} = 0.8$

- (b) (i) What is meant by simple harmonic motion? (01 mark)

Simple harmonic motion is a periodic motion where the acceleration is always directed towards a fixed point and is proportional to the displacement from that point.

- (ii) Distinguish between damped and forced oscillations (02marks)

- Damped oscillation are oscillation in which the amplitude of oscillating system gradually decrease to zero due to the presence of dissipative forces like air resistance
- Forced oscillation are those whose continuity is maintained by periodic input of energy.

- (c) A cylinder of length, L , and cross section area A and density σ floats in a liquid of density, ρ . The cylinder is pushed down slightly and released.

- (i) show that it performs simple harmonic motion. (05marks)

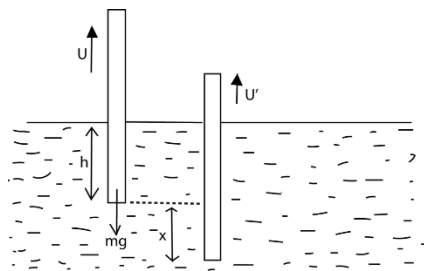

At equilibrium position, the body sinks to a height, h , below the liquid surface

Up thrust = weight of the body

But $U = Ah\rho g$

$mg = AL\sigma g$ (i)

A is the cross section area of a cylinder

When a body is displaced through a distance, x , and released,

Up thrust = $(h + x) A\rho g$

Resultant force = $mg - (h + x) A\rho g$

But, $m = Ah\rho = AL\sigma$

$$h = \frac{L\sigma}{\rho}$$

$$Ahp_a = Ahpg - Ahpg - A\rho gx$$

$$a = \frac{-A\rho gx}{Ah\rho} = \frac{-gx}{h}$$

substituting for h

$$a = -\frac{\rho g}{\sigma L}x = -kx \text{ hence simple harmonic motion}$$

(ii) Derive the expression for period of the oscillation. (02marks)

$$\omega = \sqrt{\frac{\rho g}{\sigma L}} \text{ but } T = \frac{2\pi}{\omega}$$

$$T = 2\pi \sqrt{\frac{\sigma L}{\rho g}}$$

(d) A spring of force constant 40Nm^{-1} is suspended vertically. A mass of 0.1kg suspended from the spring is pulled down a distance of 5mm and released. Find the

(i) period of the oscillation (02marks)

$$\omega = \sqrt{\frac{k}{m}} \text{ but } T = \frac{2\pi}{\omega}$$

$$T = 2\pi \sqrt{\frac{m}{k}} = 2\pi \sqrt{\frac{0.1}{40}} = 0.314\text{s}$$

(ii) maximum acceleration of the mass (02marks)

$$\omega^2 = \frac{k}{m} = \frac{400}{0.1} = 400$$

$$a_{\max} = \omega^2 x = 400 \times 5 \times 10^{-3} = 2\text{ms}^{-2}$$

(iii) net force acting on the mass when it is 2mm below the centre of oscillation. (02marks)

$$F = kx = 40 \times 2 \times 10^{-3} = 0.08\text{N}$$

39. (a) Define viscosity of a fluid (01mark)

Viscosity is the frictional force between layers of a liquid.

(b) (i) Derive an expression for terminal velocity attained by a sphere of density, σ , and radius, a , falling through a fluid of density, ρ and viscosity, η . (05marks)

At terminal velocity, $mg = U + F$

$$\Rightarrow \frac{4}{3}\pi a^3 \sigma g = \frac{4}{3}\pi a^3 \rho g - 6\pi a \eta v_0$$

$$v_0 = \frac{2ga^2(\sigma - \rho)}{9\eta} \text{ where;}$$

σ = density of the sphere

ρ = density of the liquid

η = viscosity of the fluid

g = acceleration due to gravity

v_0 = terminal velocity

(ii) Explain the variation of viscosity of a liquid with temperature. (02marks)

As temperature increases, the separation of molecules increase and the intermolecular forces decrease leading to the decrease in viscosity.

(c) (i) State the laws of friction. (02marks)

- The frictional force between two surfaces opposes their relative motion.
- The frictional force is independent of the area of contact of the given surfaces when the normal reaction is constant,
- The limiting frictional force is proportional to the normal reaction for the case of static friction. The frictional force is proportional to the normal reaction for the case of kinetic (dynamic) friction, and is independent of the relative velocity of the surfaces.

(ii) With the aid of a well labelled diagram, describe an experiment to determine the coefficient of kinetic friction between two surfaces. (05marks)

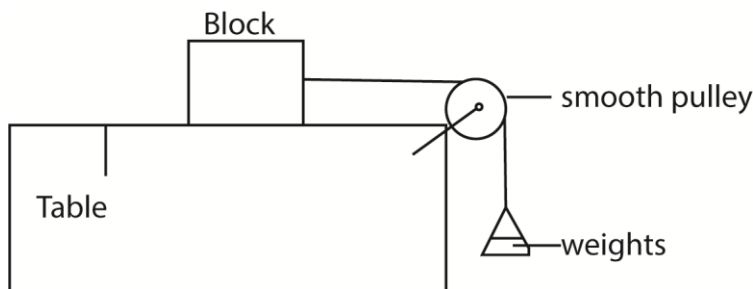

- A block of mass m is placed on a flat table and connected to a scale pan as shown in the diagram above.
- Small weights are added in bits on to the scale pan until the block just starts to move. The total weight of the scale pan and weights added is obtained, W_f .
- The coefficient of static friction, $\mu = \frac{W_f}{mg}$

Alternative method

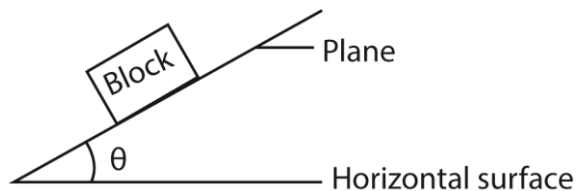

- A block is placed on horizontal plane. The plane is tilted gently until the block just start to slide
- The angle of tilt θ is measured
- The coefficient of static friction, $\mu = \tan\theta$

(d) A body slides down a rough plane inclined at 30° to horizontal. If the coefficient of kinetic friction between the body and the plane is 0.4, find the velocity after it has travelled 6m along the plane. (05marks)

$$\text{From } ma = mg\sin\theta - \mu mg\cos\theta$$

$$a = 9.81\sin 30 - 0.4 \times 9.81 \times \cos 30 = 1.5\text{ms}^{-2}.$$

$$\text{From } v^2 = u^2 - 2as$$

$$v^2 = 0 + 2 \times 1.5 \times 6$$

$$v = 4.243\text{ms}^{-1}$$

40. (a) (i) Describe the terms tensile stress and tensile strain as applied to a stretched wire. (02marks)

- Tensile stress is the ratio of the stressing force applied on the wire to the cross sectional area of the wire.
 - Tensile strain is the ratio of extension in a wire to original length of the wire.
- (ii) Distinguish between elastic limit and proportional limit. (02marks)
- Elastic limit is the point beyond which a material does not regain its original length and shape when the load is removed.
 - Proportional limit is a point beyond which the extension of a material is not proportional to the applied force or load.
- (b) With the aid of a labelled diagram, describe an experiment to investigate the relationship between tensile stress and tensile strains of a steel wire. (07marks)

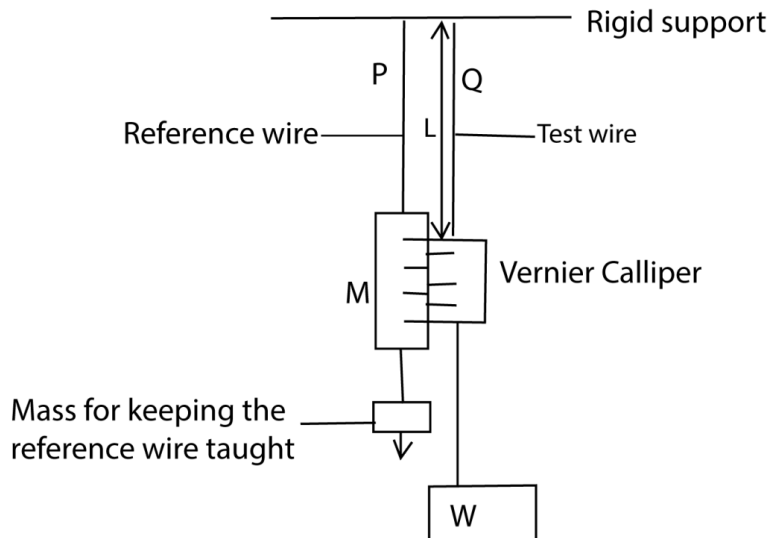

- Two thin, long wires of the same material and length P and Q are suspended from a rigid support.
 - P carries a scale M in mm and it's straightened by attaching a weight at its end.
 - Q carries a Vernier scale which is alongside scale M
 - Various loads are added to the test wire and corresponding extensions caused are read off from a vernier scale.
 - The diameter (2r) of the wire is obtained by a micrometre screw gauge, and the cross section area of the wire $A = 4\pi r^2$
 - The strain, $\frac{e}{l_0}$ and stress, $\frac{F}{A}$ are obtained
 - The procedure is repeated for different values of F and e
 - A graph of stress against strain is plotted. From the graph it is found that in the first part stress is proportional to strains up to a certain point beyond which it not proportional.
- (c)(i) A load of 60N is applied to a steel wire of length 2.5m and cross sectional area of 0.22mm^2 . If Young's Modulus for steel is 210GPa, find the expansion produced. (03marks)
- $$\Delta t = \frac{FL}{AE} = \frac{60 \times 2.5}{(0.22 \times 10^{-6} \times 210 \times 10^9)} = 3.25 \times 10^{-3}\text{m}$$
- (ii) If the temperature rise of 1K causes a fractional increase of 0.001%, find the change in length of a steel wire of length 2.5 when the temperature increases by 4K. (03marks)
- 1K causes an extension of $\frac{2.5 \times 0.001}{100}$

4K causes an extension of $\frac{2.5 \times 0.001}{100} \times \frac{4}{1} = 1 \times 10^{-4} \text{m}$

(d) The velocity, V , of a wave in a material of Young's Modulus, E and density, ρ , is given by

$$V = \sqrt{\frac{E}{\rho}}. \text{ Show that the relationship is dimensionally correct. (03marks)}$$

LHS, $[V] = \text{LT}^{-1}$ (i)

Since $[E] = \text{ML}^{-1}\text{T}^{-2}$ and $[\rho] = \text{ML}^{-3}$

$$\Rightarrow \text{RHS} = \left[\frac{\text{ML}^{-1}\text{T}^{-2}}{\text{ML}^{-3}} \right]^{\frac{1}{2}} = \text{LT}^{-1} \text{ (ii)}$$

From eqn. (i) and eqn. (ii) the relation is dimensionally consistent.

41. (a) (i) Define the term impulse (01mark)

Impulse is the product of force and time for which the force acts.

(ii) State Newton's laws of motion (03marks)

- A body continues in its state of rest or uniform motion in a straight line unless acted upon by an external force
- The rate of change of momentum of a body is directly proportional to applied force and takes place in the direction of the force
- For every action, there is an equal and opposite reaction

(b) A bullet of mass 10g travelling horizontally at a speed of 100ms^{-1} strikes a block of wood of mass 900g suspended by a light vertical string and is embedded in the block which subsequently swings freely. Find the

(i) vertical height through which the block rises. (04marks)

From $mu = (m + M)v$

$$10 \times 10^{-3} \times 100 = (10 \times 10^{-3} + 900 \times 10^{-3})v$$

$$v = 1.1\text{ms}^{-1}$$

Using $v^2 = u^2 + 2as$

$$0 = 1.1^2 - 2gh$$

$$h = 6.2 \times 10^{-2}\text{m}$$

(ii) Kinetic energy lost by the bullet (03marks)

K.E lost = K.E before collision – K.E after collision

$$= \frac{1}{2} \times 10 \times 10^{-3} \times 100^2 - \frac{1}{2} \times 910 \times 10^{-3} \times 1.1^2 = 49.45\text{J}$$

(c) Explain the terms time of flight and range as applied to projectile motion. (02marks)

- Time of flight is the time taken by the projectile to move from the point of projection to the point where it lands on a plane through the point of projection.
- Range is the horizontal distance from the point of projection to the point where the projectile lands along the plane through the point of projection.

(d) A stone is projected at an angle of 20° in horizontal and just clears a wall which is 10m high and 30m from the point of projection. Find the

(i) speed of projection. (04marks)

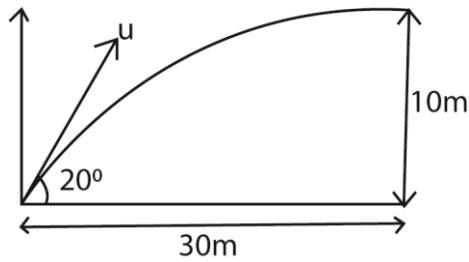

$$\text{Using } y = x \tan \alpha + \frac{gx^2 \sec \alpha}{2u^2}$$

$$10 = 30 \tan 20^\circ - \frac{9.81 \times 30^2 \sec 20^\circ}{2u^2}$$

$$u = 71.5 \text{ms}^{-1}$$

(ii) Angle which the stone makes with the horizontal as it clears the wall. (03marks)

$$u_x = 71.5 \cos 20 = 67.188 \text{ms}^{-1}$$

$$u_y = 71.5 \sin 20 - 9.81 \times \frac{30}{71.5 \cos 20} = 20.07 \text{ms}^{-1}$$

$$\tan \theta = \frac{20.07}{67.188}$$

$$\theta = 16.6^\circ$$

42. (a) Define the following terms

(i) Velocity

Velocity is the rate of change of displacement with time

(ii) Moment of a force

Moment of force is the product of the force and perpendicular distance from the point to the point of action of the force.

(b) (i) A ball is projected vertically up wards with a speed of 50ms^{-2} . on return it passes a point of projection, and falls and falls 78m below. Calculate the total time taken. (05marks)

$$\text{From } s = ut + \frac{1}{2}at^2$$

$$-78 = 50t - \frac{1}{2} \times 9.81 \times t^2; t = 11.57 \text{s}$$

(ii) State energy changes that occurred during the motion of the ball in (b)(i) above. (03marks)

K.E \rightarrow P.E + K.E \rightarrow P.E \rightarrow P.E + K.E \rightarrow K.E \rightarrow sound + heat

(c) (i) State the conditions required for mechanical equilibrium to be attained. (02marks)

The algebraic sum of moments of all forces about a point is zero

(ii) A uniform ladder of mass 40kg length 5m, rests with its upper end against a smooth vertical wall and with its lower end at 3m from the wall on a rough ground. Find the magnitude and direction of the force exerted at the bottom of the ladder. (06marks)

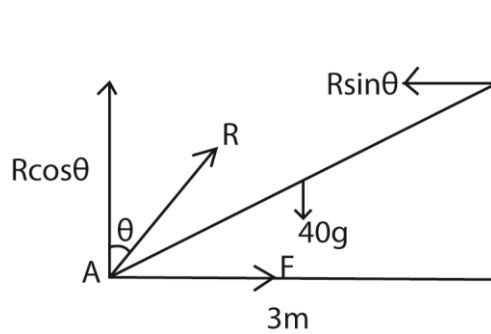

$$R \cos \theta = 40g \dots\dots\dots (i)$$

Taking moments about A

$$4R \sin \theta = 40g \times \frac{3}{2}$$

$$R \sin \theta = 15g \dots\dots\dots (ii)$$

By squaring Eqn. (i) and Eqn. (ii) and adding them;

$$R^2 \cos^2 \theta + R^2 \sin^2 \theta = 1600g^2 + 225g^2$$

$$R = 42.72g = 42.72 \times 9.81 = 420N$$

Eqn. (ii) \div Eqn. (i)

$$\tan \theta = \frac{15g}{40g} = 0.375$$

$$\theta = 20.60$$

\therefore the force at the bottom = 420N at an angle 20.6° to the vertical

(d) State four instances where increasing friction is useful. (02marks)

- Walking
- Sharpening of blades
- Lighting a match
- Braking of vehicles.

43. (a) What is meant by simple harmonic motion? (01mark)

Simple harmonic motion is a motion whose acceleration is directly proportional to the displacement from a fixed point and is directed towards the fixed point.

(b) A cylindrical vessel of cross-section area A , contains air of volume V , at pressure, P , trapped by frictionless air tight piston of mass, M . the piston is pushed down and released.

(i) If the piston oscillates with simple harmonic motion, show that its frequency, f , is given by

$$f = \frac{A}{2\pi} \sqrt{\frac{P}{MV}} \quad (06marks)$$

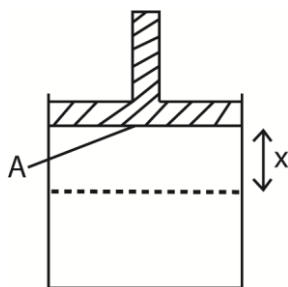

$P = \frac{F}{A}$; $F = PA = mg$ where $m =$ mass of the piston pushed through a small distance, dx .

Restoring force, $F_r = (P_2A - mg)$

$$\Rightarrow -(P_2A - mg) = ma$$

$$- (P_2A - PA) = ma \dots\dots\dots (i)$$

From Boyles's law

$$P_1V_1 = P_2V_2 = PV$$

$$\Rightarrow P_2(V-Ax) = PV$$

$$P_2 = \frac{PV}{V-Ax}$$

$$\therefore -PA\left(\frac{V}{V-Ax} - 1\right) = -PA\left(\frac{Ax}{V-Ax}\right) = ma$$

$$\text{For small } x; ma = -\left(\frac{PA^2x}{V}\right) \Rightarrow a = -\left(\frac{PA^2}{mV}\right) x;$$

Compare with $a = -\omega^2x$ for S.H.M

$$\Rightarrow \omega^2 = \left(\frac{PA^2}{mV}\right) \Rightarrow \omega = \sqrt{\frac{PA^2}{mV}} = 2\pi f$$

$$\Rightarrow f = \frac{A}{2\pi} \sqrt{\frac{P}{mV}}$$

(ii) Show that the expression for f , in (b)(i) is dimensionally correct. (03marks)

$$[f] = \left[\frac{A}{2\pi} \sqrt{\frac{P}{mV}} \right]$$

$$[\text{L.H.S}] = T^{-1}$$

$$[\text{R.H.S}] = \sqrt{\frac{L^4ML^{-1}T^{-2}}{ML^3}} = T^{-1}$$

$$[\text{L.H.S}] = [\text{R.H.S}]$$

Hence the equation is dimensionally correct

(c) A particle executing simple harmonic motion vibrates in a straight line. Given that the speeds of the particle are 4ms^{-1} and 2ms^{-1} when the particle is 3cm and 6cm respectively from the equilibrium, calculate the

(i) amplitude of oscillation. (03marks)

$$\text{From } v^2 = \omega^2(a^2 - x^2)$$

$$16 = \omega^2(a^2 - (3 \times 10^{-2})^2) \dots\dots\dots \text{(i)}$$

$$4 = \omega^2(a^2 - (6 \times 10^{-2})^2) \dots\dots\dots \text{(ii)}$$

From equations (i) and (ii)

$$a = 6.7\text{cm}$$

$$\omega = 66.67\text{rads}^{-1}$$

(ii) frequency of the particle. (03marks)

$$\text{From } \omega = 2\pi f$$

$$f = \frac{66.67}{2\pi} = 10.6\text{s}^{-1}$$

(d) Give two examples of oscillatory motion which approximate to simple harmonic motion and state the assumption made in each case. (04marks)

- Swing of a suspended pendulum bob
- Vibration of a loaded spring

44. (a) (i) State Archimedes' Principle. (01mark)

Archimedes' Principle states that when an object is wholly or partially immersed in a fluid, it experiences an up thrust equal to the weight of the fluid displaced.

(ii) Use Archimedes' Principle to derive an expression for resultant force on a body of weight, W , and density, σ , totally immersed in a fluid of density, ρ . (04marks)

$$\text{Up thrust (U) = weight of fluid displaced}$$

$$= mg$$

$$= V\rho g$$

$$\text{Resultant force } Fr = W - V\rho g \text{ but } V = \frac{W}{\sigma g}$$

$$\therefore Fr = W - \frac{W\rho g}{\sigma g} = W\left(1 - \frac{\rho}{\sigma}\right)$$

(b) A tube of uniform cross sectional area of $4 \times 10^{-3}\text{m}^2$ and mass 0.2kg is separately floated vertically in water of density $1.0 \times 10^3\text{kgm}^{-3}$ and in oil of density $8.0 \times 10^2\text{kgm}^{-3}$. Calculate the difference in the lengths immersed (04marks)

$$m = PV = \rho AL$$

$$\text{For water, } L_w = \frac{m}{A\rho} = \frac{0.2}{1000 \times 4 \times 10^{-3}} = 0.05\text{m}$$

$$\text{For oil, } L_o = \frac{m}{A\rho} = \frac{0.2}{800 \times 4 \times 10^{-3}} = 0.0625\text{m}$$

Difference in length = $0.0625 - 0.05 = 0.0125\text{m}$

(c) (i) Define surface tension in terms of work (01mark)

Surface tension is the work done to increase the surface area of a liquid under isothermal conditions.

(ii) Use the molecular theory to account for surface tension of a liquid. (04marks)

- Liquid molecules attract each other.
- The molecules within the body of the liquid (bulk) molecules is attracted equally by neighbors in all direction, hence, the force on the bulk molecules is zero,
- For a surface molecules, there is a net inward force because there are no molecules above the surface to attract them equally.

- To the surface, work must be done against the inward attractive force, hence, a molecule in the surface of a liquid has a greater potential energy than a molecule in the bulk. The potential energy stored in molecules at the surface is called free surface energy or surface tension.

- Due to the attractive forces experienced by surface molecules due to their neighbours put in a state of tension; the liquid surface behave as a stretched skin.

(iii) Explain the effect of increasing temperature of a liquid on its surface tension. (04marks)

When a liquid is heated, the average kinetic energy of its molecules increase. So the intermolecular of attraction decrease because molecules spend less time in the neighbourhood of a given molecule. At the same time, more molecule enter the liquid surface which lowers the potential energy of the surface thereby lowering the surface tension.

(iv) Calculate the excess pressure inside a soap bubble of diameter 3.0cm if the surface tension of the soap solution is $2.5 \times 10^{-2}\text{Nm}^{-1}$. (02marks)

$$\text{Excess pressure} = \frac{4\gamma}{r} = \frac{4 \times 2.5 \times 10^{-2}}{1.5 \times 10^{-2}} = 6.67\text{Pa}$$

45. (a) (i) Define the term velocity and displacement. (02marks)

Velocity is the rate of change of displacement

Displacement is the distance moved in specified direction

(ii) Sketch velocity against time for an object thrown vertically upwards. (02marks)

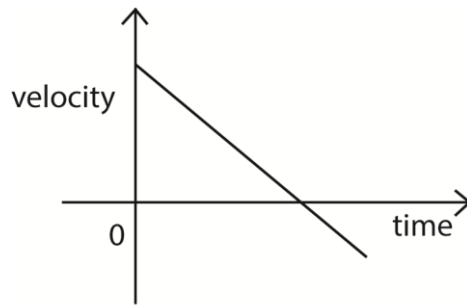

(b)

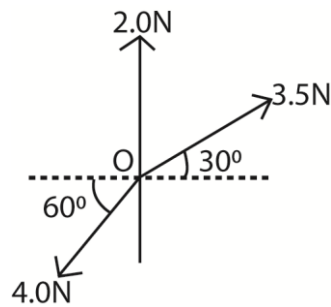

Three forces of 3.5N, 4.0N and 2.0N, act at O as shown in the figure above. Find the resultant force. (04marks)

Suppose the components of the resultant force of the x and y direction are X and Y respectively;

$$F_x = 3.5 \cos 30^\circ - 4 \cos 60^\circ = 1.031 \text{ N}$$

$$F_y = 2.0 + 3.5 \sin 30^\circ - 4.0 \sin 60^\circ = 0.286 \text{ N}$$

$$F = \sqrt{F_x^2 + F_y^2} = \sqrt{1.031^2 + 0.286^2} = 1.07 \text{ N}$$

$$\theta = \tan^{-1} \left(\frac{0.286}{1.031} \right) = 15.5^\circ$$

the resultant force is 1.07N making 15.5° with the horizontal.

(c) (i) What is meant by saying that a body is moving with velocity relative to another? (01marks)

If a body is moving with a velocity, v , relative to another means that it has velocity, v , as seen by an observer from another body.

(ii) A ship, A is travelling due north at 20 km h^{-1} and ship B is travelling due east at 15 km h^{-1} . Find the velocity of A relative to B. (03marks)

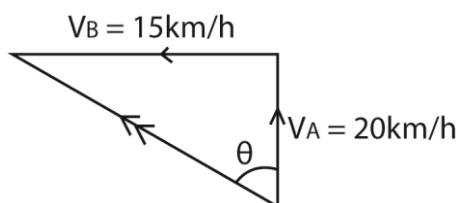

$${}_A V_B = \sqrt{20^2 + 15^2} = 25 \text{ km/h}$$

$$\theta = \tan^{-1} \left(\frac{15}{20} \right) = 36.9^\circ$$

the relative velocity of A relative to B = 25km/h in the direction N36.9°W

- (iii) If the ship B in (c)(ii) is 10km due west of A at noon. Find the shortest distance apart and when it occurs. (05marks)

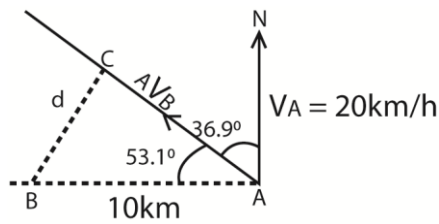

d is the shortest distance of approach

$$d = 10 \sin 53.1^\circ = 8 \text{ km}$$

$$\text{Time taken} = \frac{\text{distance along the relative path}}{\text{relative velocity}} = \frac{10 \cos 53.1^\circ}{25} = 0.24 \text{ hours.}$$

- (d) (i) What is meant by a couple in mechanics? (01mark)

A couple is a pair of equal parallel and opposite forces whose line of action do not coincide.

- (ii) State the conditions for equilibrium of a system of coplanar forces

The vector sum of all forces must be zero i.e. in translational equilibrium

Or

The algebraic sum of all the moments of the forces about any point is zero, i.e. there is not rotation equilibrium.

46. (a) (i) State the laws of friction between solid surfaces (03marks)

- The frictional force between two surfaces opposes their relative motion.
- The frictional force is independent of the area of contact of the given surfaces when the normal reaction is constant,
- The limiting frictional force is proportional to the normal reaction for the case of static friction. The frictional force is proportional to the normal reaction for the case of kinetic (dynamic) friction, and is independent of the relative velocity of the surfaces.

- (ii) Explain the origin of friction force between two solid surfaces in contact. (03marks)

- For any two solid surfaces in contact, there are small humps and hollows that form contact points.
- Therefore, the actual area of contact is indeed small which creates very high pressure at the points of contact.
- This pushes the molecules very close that the forces of attraction between them welds the surfaces at these points.
- Thus, a force that opposes motion in any direction is created.

- (iii) Describe an experiment to measure the coefficient of kinetic friction between two solid surfaces. (03marks)

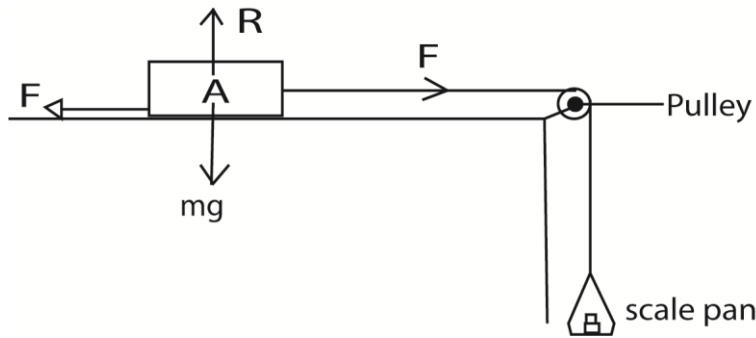

- A block of mass m is placed on a flat table and connected to a scale pan as shown in the diagram above.
- Weights are added to the scale-pan, and each time A is given a slight push.
- At one stage A continues to move with a constant velocity.
- The coefficient of kinetic friction, $\mu = \frac{W_f}{mg}$; where W_f = weight of the scale pan plus added weights.

(b) (i) A car of mass 1000kg moves along a straight surface with speed of 20ms^{-1} . When brakes are applied steadily, the car comes to rest after travelling 50m. Calculate the coefficient of friction between the surface and the tyre. (04marks)

Initial kinetic energy of the car = work done against friction

$$\frac{1}{2}mu^2 = F \times s$$

$$\frac{1}{2} \times 1000 \times 20^2 = F \times 50$$

$$F = 4000\text{N}$$

$$\text{But } F = \mu R = \mu mg$$

$$\begin{aligned} \Rightarrow 4000 &= \mu \times 1000 \times 9.81 \\ \mu &= 0.408 \end{aligned}$$

(ii) State the energy changes which occur from the time brakes are applied to the time the car comes to rest. (02marks)

Kinetic energy \rightarrow heat and sound

(c) (i) State two disadvantages of friction (01mark)

- Wears machines
- Wears shoes
- Causes unnecessary noise in moving parts of a machines.
- Produces unnecessary heat

(ii) Give one method of reducing friction between solid surfaces. (01mark)

- By lubrication
- Using ball bearings or rollers
- Making surfaces smooth

(d) Explain what happens when a small steel ball is dropped centrally in a tall jar containing oil. (03marks)

- It experiences a drag force, F and an up thrust, U , upwards and weight, W , downwards.
- Initially, $W > F + U$, so the ball accelerates downwards.
- As velocity increases, F increases until a time when $W = F + U$, and consequently ball moves with a constant terminal velocity.

47. (a) (i) Define simple harmonic motion. (01mark)

It is periodic motion in which the acceleration of the body along the path of the body is directed towards a fixed point in the line of motion and is proportional to the displacement of the body from a fixed point

(ii) A particle of mass m executes simple harmonic motion between two points A and B about equilibrium position O. sketch a graph of the restoring force acting on the particle as a function of distance, r , moved by the particle. (02marks)

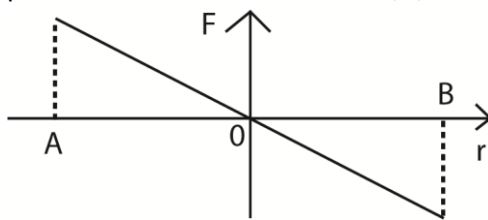

(b)

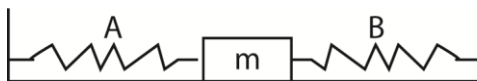

Two springs A and B of spring constant K_A and K_B respectively are connected to mass m as shown in the figure above. The surface on which the mass slides is frictionless.

(i) Show that when the mass is displaced slightly, it oscillates with simple harmonic

motion of frequency, f given by $f = \frac{1}{2\pi} \sqrt{\frac{K_A + K_B}{m}}$ (04marks)

If the body is displaced through a small displacement, x towards B;

$$\Rightarrow \text{Resultant force } F = (K_A + K_B)x$$

$$\text{From } F = ma$$

$$ma = -(K_A + K_B)x$$

$$a = -\left(\frac{K_A + K_B}{m}\right)x$$

This is of the form $a = -\omega^2 x$ where $\omega = \sqrt{\left(\frac{K_A + K_B}{m}\right)}$, hence simple harmonic motion.

(ii) If the two springs in the figure above are identical such that $K_A = K_B = 5.0 \text{ Nm}^{-1}$ and mass $m = 50 \text{ g}$, calculate the period of oscillation (03marks)

$$\omega = 2\pi f = \sqrt{\left(\frac{K_A + K_B}{m}\right)}$$

$$f = \frac{1}{2\pi} \sqrt{\left(\frac{K_A + K_B}{m}\right)}$$

$$T = \frac{1}{f} = 2\pi \sqrt{\frac{m}{K_A + K_B}} = 2\pi \sqrt{\frac{50 \times 10^{-3}}{5.0 + 5.0}} = 0.44\text{s}$$

- (c) (i) With the aid of a diagram, describe an experiment to determine the universal gravitational constant, G. (06marks)

Determining gravitational constant

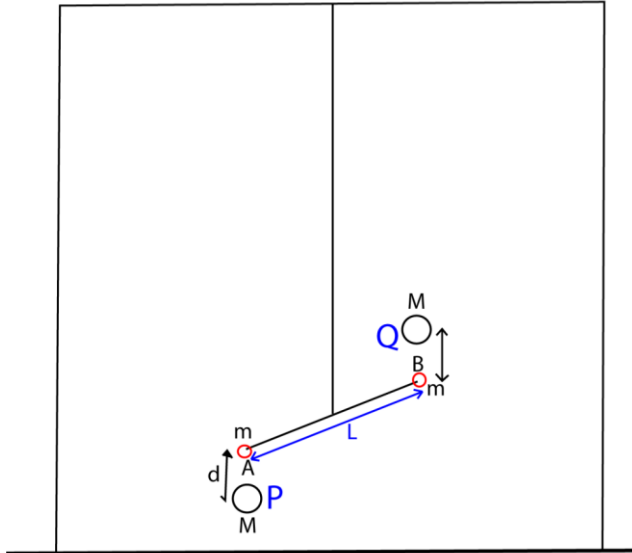

- Two equal lead spheres A and B each of mass, m, are attached to end of a bar AB of length, L.
- The bar AB is suspended from a ceiling.
- Large spheres P and Q are brought towards A and B respectively from the opposite side
- Large spheres P and Q altered small spheres A and B respectively by equal and opposite gravitational forces give rise to gravitational torque, F, which in turn twist the suspended through angle θ .
- A resting torque of the wire opposes the twisting of the wire from equilibrium position

Then

$$F = C\theta = \frac{GMm}{d^2}$$

$$G = \frac{C\theta d^2}{MmL}$$

Where

d = distance between the centre of A and P or B and Q.

C = the twisting couple per unit twist ($\theta = 1$)

- (ii) If the moon moves round the earth in a circular orbit of radius = $4.0 \times 10^8\text{m}$ and takes exactly 27.3 days to go round once, calculate the value of acceleration due to gravity, g, at the earth's surface. (04marks)

$$\frac{GmM}{R^2} = m\omega^2 R; \text{ But } GM = gr_s^2$$

$$\Rightarrow \frac{gr_s^2}{R^2} = \omega^2 R$$

$$g = \frac{\omega^2 R^3}{r_s^2}$$

$$\omega = \frac{2\pi}{T}$$

$$g = \frac{4\pi^2 R^3}{T^2 r_s^2} = \frac{4\pi^2 (4.0 \times 10^8)^3}{(27.3 \times 24 \times 60 \times 60)^2 (6.4 \times 10^6)^2} = 11.09 \text{ms}^{-2}$$

48. (a) State

(i) Newton's laws of motion (03marks)

- A body continues in its state of rest or uniform motion in a straight line unless acted upon by an external force
- The rate of change of momentum of a body is directly proportional to applied force and takes place in the direction of the force
- For every action, there is an equal and opposite reaction

(ii) The principle of conservation of momentum (01mark)

When a body is in mechanical equilibrium, the sum of clockwise moments about any point is equal to the sum of anticlockwise moments about the same point

(b) A bod A of mass m_1 moves with velocity u_1 and collides head on elastically with another body B of mass m_2 which is at rest. If the velocities of A and B are v_1 and v_2 respectively and given that $X = \frac{m_1}{m_2}$, show that

(i) $\frac{u_1}{v_1} = \frac{X+1}{X-1}$ (04marks)

From principle of conservation of momentum

$$m_1 u_1 + m_2 u_2 = m_1 v_1 + m_2 v_2 \text{ but } u_2 = 0$$

$$\Rightarrow m_1 u_1 = m_1 v_1 + m_2 v_2$$

$$v_2 = \frac{m_1 u_1 - m_1 v_1}{m_2} = X u_1 - X v_1 = X(u_1 - v_1) \dots\dots\dots (i)$$

For an elastic collision, total kinetic energy is conserved.

$$\text{Hence: } \frac{1}{2} m_1 u_1^2 = \frac{1}{2} m_1 v_1^2 + \frac{1}{2} m_2 v_2^2$$

$$m_1 u_1^2 = m_1 v_1^2 + m_2 v_2^2 \dots\dots\dots (ii)$$

Substituting Eqn. (i) in eqn (ii)

$$m_1 u_1^2 = m_1 v_1^2 + m_2 (X(u_1 - v_1))^2$$

Divide both sides by m_2

$$X u_1^2 = X v_1^2 + (X(u_1 - v_1))^2$$

$$\Rightarrow X(u_1^2 - v_1^2) = X^2 (u_1 - v_1)^2$$

$$(u_1 + v_1)(u_1 - v_1) = X(u_1 - v_1)^2$$

$$(u_1 + v_1) = X(u_1 - v_1)$$

Collecting like terms

$$v_1(X + 1) = u_1(X - 1)$$

$$\frac{u_1}{v_1} = \frac{X + 1}{X - 1}$$

(ii) $\frac{v_2}{v_1} = \frac{2X}{X-1}$ (03marks)

From $\frac{u_1}{v_1} = \frac{X + 1}{X - 1}$

$$u_1 = v_1 \left(\frac{X+1}{X-1} \right)$$

Substituting for u_1 in Eqn. (b)(i)

$$v_2 = X \left(v_1 \left(\frac{X+1}{X-1} \right) - v_1 \right)$$

$$\begin{aligned} \frac{v_2}{v_1} &= X \left(\left(\frac{X+1}{X-1} \right) - 1 \right) = X \left(\left(\frac{X+1-X+1}{X-1} \right) \right) \\ &= \frac{2X}{X-1} \end{aligned}$$

(c) Distinguish between conservative and non-conservative forces. (02marks)

For conservative forces, the work done by the force through a closed path is zero whereas for non-conservative forces, the work done through a closed path is not zero

(d) A bullet of mass 40g is fired from a gun at 200ms^{-1} and hit a block of wood of mass 2kg which is suspended by a light vertical string 2m long. If the bullet gets embedded in the wooden block.

(i) Calculate the maximum angle the string makes with the vertical. (06marks)

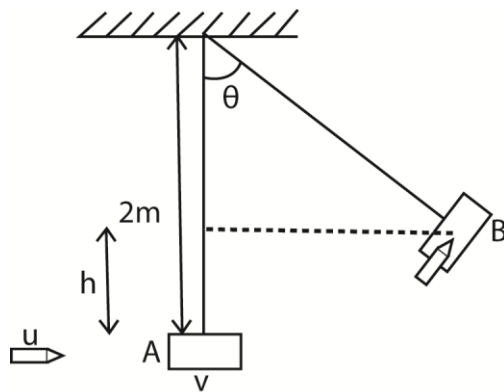

From principle of conservation of linear momentum

$$m_1 u = (m_1 + m_2) v$$

$$(40 \times 10^{-3}) \times 200 = [2 + (40 \times 10^{-3})] v$$

$$v = 3.92\text{ms}^{-1}$$

If the block after collision moves to height h to B, from the principle of conservation of mechanical energy

K.E at A = Potential energy at B

$$\frac{1}{2} m v^2 = m g h$$

$$\therefore h = \frac{v^2}{2g} = \frac{3.92^2}{2 \times 9.81} = 0.78\text{m}$$

$$\cos \theta = \frac{2-h}{2} = 0.61$$

$$\theta = 52.4^\circ$$

(ii) State a factor on which the angle of swing depends. (01mark)

- Speed of the bullet
- Length of the string
- Mass of the block

49. (a) Define simple harmonic motion (SHM). (01mark)

It is periodic motion in which the acceleration of the body along the path of the body is directed towards a fixed point in the line of motion and is proportional to the displacement of the body from a fixed point

(b) Sketch a graph of:

(i) velocity against displacement for a body executing SHM. (03marks)

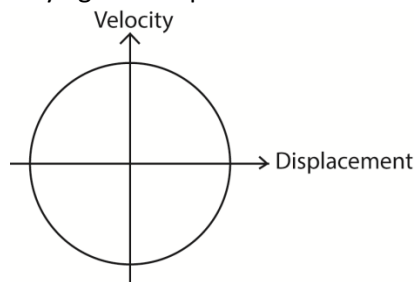

(ii) Acceleration against displacement, for a body executing SHM

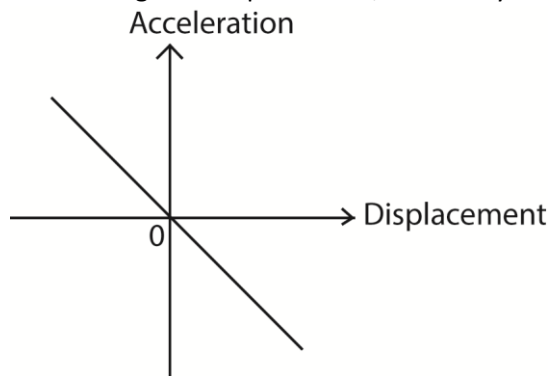

(c) A glass U-tube containing a liquid is tilted slightly and then released.

(i) Show that the liquid oscillates with simple harmonic motion. (04mark)

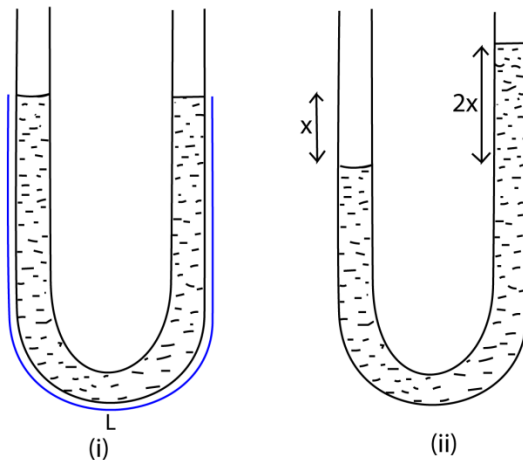

A liquid of density ρ contained in a U-tube of cross section area A and column L , if the liquid is displaced slightly through a distance x from equilibrium position

The restoring force of the liquid = $2xA\rho g$

Using Newton's 2nd law,

$$ma = -2xA\rho g$$

$$a = -\frac{2xA\rho g}{m} \text{ but, } m = AL\rho$$

$$a = -\frac{2xg}{L}$$

But $a = -\omega^2x$

$$\omega = \sqrt{\frac{2g}{L}}$$

$$T = \frac{2\pi}{\omega}$$

$$T = 2\pi\sqrt{\frac{L}{2g}}$$

$$\text{Frequency, } f = \frac{1}{T} = \frac{1}{2\pi}\sqrt{\frac{2g}{L}}$$

(ii) Explain why the oscillations ultimately come to rest. (03marks)

Resistive forces lead to loss of energy, causing a gradual decrease in amplitude and eventually oscillation die out

(d) Explain why maximum speed of a car on a banked road is higher than on an unbanked road. (04marks)

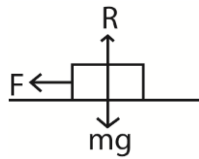

Along a circular path on a horizontal road, the frictional force provides the centripetal force

i.e. centripetal force = $\frac{mv_1^2}{r} = \mu R$

On a banked road, the centripetal force is provided by the component of normal reaction, R , and the component of friction

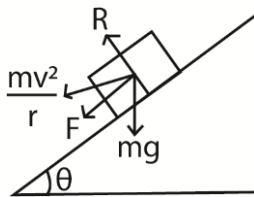

$$\text{Centripetal force} = \frac{mv_2^2}{r} = F\cos\theta + R\sin\theta$$

But $F = \mu R$

$$\text{Centripetal force} = \frac{mv_2^2}{r} = \mu R\cos\theta + R\sin\theta$$

For $0^\circ < \theta < 90^\circ$, $\mu\cos\theta + \sin\theta > \mu$

Therefore, $v_2 > v_1$

(e) A small bob of mass 0.2kg is suspended by an inextensible string of length 0.8m. The bob is then rotated in a horizontal circle of radius 0.4m. Find

(i) linear speed of the bob (03marks)

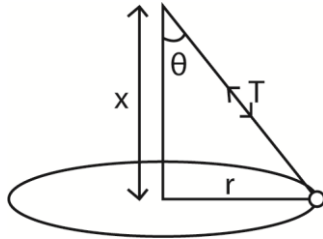

$$x^2 = 0.8^2 - 0.4^2$$

$$x = 0.692\text{m}$$

$$T \sin \theta = \frac{mv^2}{r} \dots\dots\dots (i)$$

$$T \cos \theta = mg$$

Eqn. (i) and Eqn (ii)

$$\tan \theta = \frac{v^2}{rg}$$

$$v^2 = rg \tan \theta$$

$$v = \sqrt{0.4 \times 9.81 \times \frac{0.4}{0.692}} = 1.51\text{ms}^{-1}$$

(ii) tension in the string. (02marks)

$$T = \frac{mg}{\cos \theta} = 0.2 \times 9.81 \times \frac{0.8}{0.692} = 2.29\text{N}$$

50. (a) State Kepler's laws of planetary motion. (03marks)

- Planets describe ellipses about the sun as one focus
- The imaginary line joining the sun and planet sweeps out equal areas in equal time intervals
- The square of the periodic time of revolution of planets about the sun are proportional to the cubes of their mean distance from the sun

(b) (i) A satellite moves in a circular orbit of radius, R, about a planet of mass, M, with period T. Show that $R^3 = \frac{GMT^2}{4\pi^2}$, where G is the universal gravitational constant. (04marks)

T. Show that $R^3 = \frac{GMT^2}{4\pi^2}$, where G is the universal gravitational constant. (04marks)

Force of attraction, $F = \frac{GMm}{R^2}$ where m is the mass of the satellite.

Centripetal force = $m\omega^2 R$ where $\omega = \frac{2\pi}{T}$

$$\Rightarrow \frac{GMm}{R^2} = m \left(\frac{2\pi}{T}\right)^2 R$$

$$R^3 = \frac{GMT^2}{4\pi^2}$$

(ii) The period of the moon around the earth is 27.3 days. If the distance of the moon from the Earth is $3.83 \times 10^8\text{km}$, calculate the acceleration due to gravity at the surface of the Earth. (04marks)

$$\frac{GM}{R^3} = \frac{4\pi^2}{T^2}$$

Near the earth's surface, $\frac{GMm}{r_e^2} = mg$

$$\Rightarrow GM = gr_e^2 = \frac{4\pi^2 R^3}{T^2}$$

$$g = \frac{4\pi^2 R^3}{T^2 r_e^2} = \frac{4\pi^2 (3.83 \times 10^8)^3}{(27.3 \times 24 \times 60 \times 60)^2 (6.4 \times 10^6)^2} = 9.73\text{ms}^{-2}$$

- (iii) Explain why any resistance to forward motion of an artificial satellite results into an increase in its speed. (04marks)

If the satellite encountered a resistance in orbit;

Total energy = M.E = $\frac{-GM_em_s}{2R}$ decreases. Its orbit radius R decreases to R'

$$\text{K.E} = \frac{1}{2}m_s v^2 = \frac{-GM_em_s}{2R'}$$

This means that the final kinetic energy and velocity increases.

- (c) (i) What is meant by weightlessness? (02marks)

Weightlessness is a condition of zero reaction, the body has the same acceleration as the acceleration due to gravity.

- (ii) Why does acceleration due to gravity vary with location on the surface of the earth? (03marks)

The earth is elliptical with equatorial radius bigger than the polar radius. At the equator, the body is less attracted towards the earth than at the pole. Therefore gravity at the equator is less than the gravity at the poles. The earth rotates about the polar axis. A body at the pole is practically stationary while the body towards the equator experiences a centripetal force.

$$M\omega^2 R = mg - mg'$$

$$\therefore g' = g - \omega^2 R$$

51. (a) (i) State the laws of solid friction. (03marks)

- The frictional force between two surfaces opposes their relative motion.
- The frictional force is independent of the area of contact of the given surfaces when the normal reaction is constant,
- The limiting frictional force is proportional to the normal reaction for the case of static friction. The frictional force is proportional to the normal reaction for the case of kinetic (dynamic) friction, and is independent of the relative velocity of the surfaces.

- (ii) Using molecular theory, explain the laws stated in (a)(i) (03marks)

- Actual area of contact between solid surfaces is very small. Therefore pressure at points of contact is very high; projections emerge to produce adhesion or welding. The force which oppose motion is obtained (Law I)
- The actual area of contact is the sum of the areas of tiny projections that adhere to each other and are nearly independent of the surface areas of contact.(law II)
-
- Increase in weight increases the actual area of contact and hence greater limiting frictional force.

- (b) Describe an experiment to determine the coefficient of static friction for an interface between a rectangular block of wood and plane surface. (04marks)

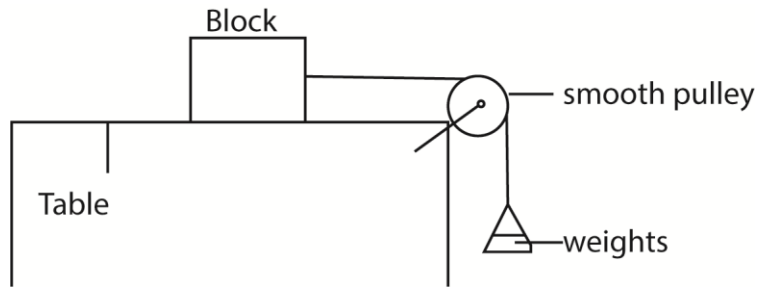

- A block of mass m is placed on a flat table and connected to a scale pan as shown in the diagram above.
- Small weights are added in bits on to the scale pan until the block just starts to move. The total weight of the scale pan and weights added is obtained, W_f .
- The coefficient of static friction, $\mu = \frac{W_f}{m.g}$

Alternative method

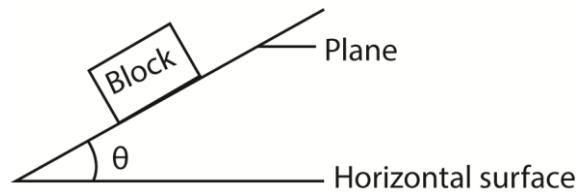

- A block is placed on horizontal plane. The plane is tilted gently until the block just start to slide
- The angle of tilt θ is measured
- The coefficient of static friction, $\mu = \tan\theta$

(c) (i) State the difference between conservative and non-conservative forces, give one example each. (03marks)

For conservative forces, the work done by force in a closed loop is zero e.g. gravitational force, magnetic force and electrostatic force

For non-conservative forces, work done by force in a closed loop is not zero. E.g. frictional force.

(ii) State the work-energy theorem. (01mark)

Work done by the resultant force on the body is equal in kinetic energy of the body

(iii) A block of mass 6.0kg is projected with a velocity of 12ms^{-1} up a rough plane inclined at 45° to horizontal. If it travels 5.0m up the plane, find the friction force. (04marks)

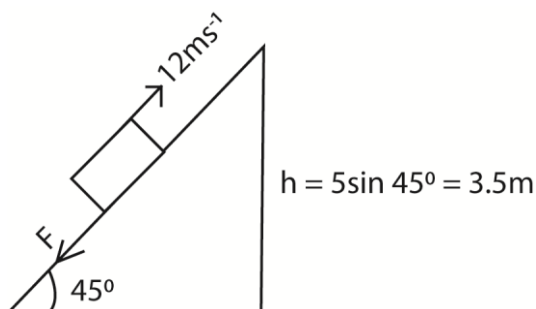

Initial kinetic energy = work done against resistance force.

$$\therefore \frac{1}{2}mv^2 = mgsin 45^\circ + F \times s$$

$$\frac{1}{2} \times 6 \times 12^2 = 6 \times 9.81 \times \sin 45^\circ + F \times 5$$

$$F = 44.8\text{N}$$

(d) Explain the effect of temperature on the viscosity of a liquid.

An increase in temperature of a liquid leads to an increase in molecular separation which weakens the intermolecular forces of attraction thereby reducing viscosity.

52. (a) (i) Define vector and scalar quantities and give one example of each. (03marks)

A vector quantity has both magnitude and direction e.g. velocity, displacement, force, acceleration due to gravity

A scalar quantity has only magnitude e.g. mass, volume, speed

(ii)

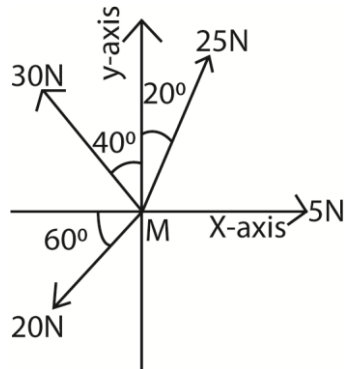

A body, M, of mass 6kg is acted on by forces of 5N, 20N, 25N and 30N as shown in the figure above. Find the acceleration of M (05marks)

Resolving horizontally: $5 + 25\cos 70^\circ - 30\cos 50^\circ - 20\cos 60^\circ = -15.73\text{N}$

Resolving vertically: $30\sin 50^\circ + 25\sin 70^\circ - 20\sin 60^\circ = 29.15\text{N}$

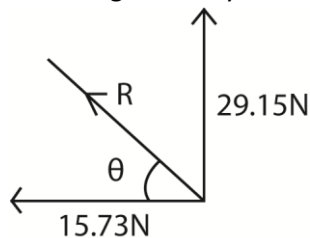

$$R = \sqrt{29.15^2 + 15.73^2} = 33.12\text{N}$$

$$\theta = \tan^{-1} \left(\frac{29.15}{15.73} \right) = 61.7^\circ$$

From $F = ma$

$$a = \frac{33.12}{6} = 5.52\text{ms}^{-1}$$

(b) (i) What is meant by acceleration due to gravity? (01mark)

Acceleration due to gravity is the force of attraction due to gravity exerted on 1kg mass. Or is the rate of change of velocity of a body moving freely under gravity.

(ii) Describe how you would use a spiral spring, a retort stand with a clamp, a pointer, seven 50g masses, a meter rule and a stop clock to determine the acceleration due to gravity. (06marks)

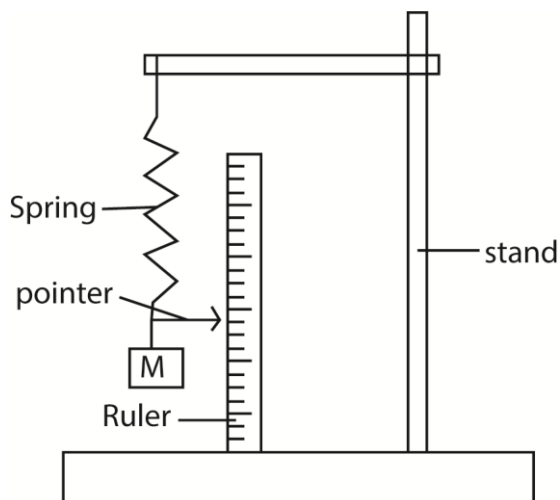

- Suspend a spiral spring from the clamp of a retort stand.
- Attach the pointer to the free end of the spring such that it is horizontal.
- Read and record the initial pointer position on a meter rule supported vertically.
- Suspend a 50g mass from the spring and record the new position of the pointer and calculate the extension, x , of the spring
- Displace the 50g mass through a small vertical distance and release it.
- Measure the time for a reasonable number of oscillations
- Calculate the period T of oscillations. Repeat the procedure for different value of masses.
- Plot a graph of T^2 against x , and find the slope, S , of the graph
- Calculate g from $g = \frac{4\pi^2}{S}$

(iii) State any two sources of error in the experiment in (b)(ii) above. (01marks)

- Reading positions of the pointer
- Determining period T

(iv) A body of mass 1kg moving with simple harmonic motion has speeds of 5ms^{-1} and 3ms^{-1} when it is at distances of 0.10m and 0.2m respectively from equilibrium point. Find the amplitude of the motion. (04marks)

$$v^2 = \omega^2(A^2 - x^2)$$

$$5^2 = \omega^2(A^2 - 0.1^2) \dots\dots\dots (i)$$

$$3^2 = \omega^2(A^2 - 0.2^2) \dots\dots\dots (ii)$$

From (i) and (ii)

$$A = 0.24\text{m}$$

53. (a)(i) What is meant by uniformly accelerated motion? (01marks)

Uniformly accelerated motion is one for which velocity increases by equal amounts in equal successive time interval

(ii) Sketch the speed against time graph for a uniformly accelerated body. (01mark)

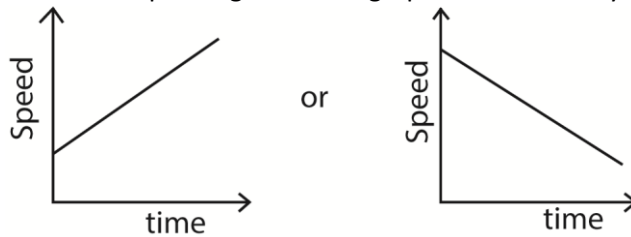

(iii) Derive the expression: $S = ut + \frac{1}{2} at^2$, for the distance, S , moved by a body which is initially travelling with speed u and is uniformly accelerated for time t .

$$s = \left(\frac{u+v}{2}\right) t \text{ but } v = u + at$$

$$s = \frac{(u+u+at)t}{2}$$

$$= ut + \frac{1}{2} at^2$$

(b) A projectile is fired horizontally from the top of a cliff 250m high. The projectile lands 1.414×10^3 m from the bottom of the cliff. Find the

(i) initial speed of the projectile. (05marks)

$$\text{From } y = u_y t + \frac{1}{2} at^2$$

$$-250 = 0 - \frac{1}{2} \times 9.81 \times t^2;$$

$$t = 7.14\text{s}$$

Horizontally, $x = u_x t$

$$1.414 \times 10^3 = 7.14 u_x$$

$$u_x = 198\text{ms}^{-1}$$

(ii) velocity of the projectile just before it hits the ground. (05marks)

$$v_y = u_y + at$$

$$= 0 - 9.81 \times 7.14 = 70\text{ms}^{-1}$$

$$v = \sqrt{u_x^2 + u_y^2} = \sqrt{198^2 + 70^2} = 210\text{ms}^{-1}$$

$$\theta = \tan^{-1}\left(\frac{70}{198}\right) = 19.5^\circ \text{ to the horizontal}$$

(c) Describe an experiment to determine the centre of gravity of a plane sheet of material having irregular shape (04marks)

- three holes are drilled around the edge of the sheet of irregular object.
- The cardboard is suspended from a pin through one of the holes. When the cardboard is freely suspended, a plumb line is suspended from the same pin.
- A line is drawn to mark the line where the plumb line passes.
- The procedure is repeated for the other two holes.

- The point of intersection of the three line is the centre of gravity

54. (a) (i) Define force and power. (02marks)

A force is something that changes or tends to change a body's state of rest or uniform motion in straight line.

Power is the rate of doing work

(ii) Explain why more energy is required to push a wheel barrow uphill than on a level ground. (03mark)

(b)

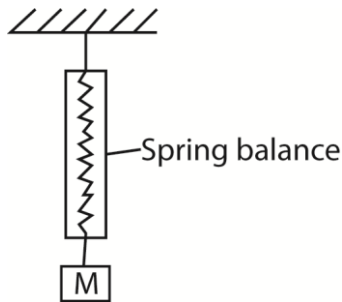

A mass, M, is suspended from a spring balance as shown in the figure above. Explain what happens to the reading of the spring balance when the setup is raised slowly to a very high height above the ground. (02marks)

On a level ground, work is only done against frictional force, while when moving uphill work is done against friction force and gravity. As the setup is raised to a greater height, acceleration due to gravity decrease; so the weight of M decreases, therefore the reading of the spring balance also decreases.

(c) (i) State the work-energy theorem (01mark)

Work done by the resultant force on the body is equal in kinetic energy of the body

(ii) A bullet of mass 0.1kg moving horizontally with a speed of 420ms^{-1} strikes a block of mass 2.0kg at rest on a smooth table and becomes embedded in it. Find the kinetic energy lost if they move together. (04marks)

$$m_1 u_1 = (m_1 + m_2)v$$

$$0.1 \times 420 = 2.1v$$

$$v = 20\text{ms}^{-1}$$

$$\begin{aligned} \text{loss in K.E} &= \frac{1}{2} m_1 u^2 - \frac{1}{2} (m_1 + m_2) v^2 \\ &= \frac{1}{2} \times 0.1 \times 420^2 - \frac{1}{2} \times 2.1 \times 20^2 \\ &= 8400\text{J} \end{aligned}$$

(d) State the condition for equilibrium of a rigid body under the action of coplanar forces. (02marks)

- the sum of forces acting in any one direction is equal to the sum of forces acting in the opposite direction (the resultant force on the body = 0)

- the sum of clockwise moments about any point is equal to the sum of anticlockwise moments about the same point.

(e) A 3m long ladder rests at an angle 60° to the horizontal against a smooth vertical wall on a rough ground. The ladder weighs 5kg and its centre of gravity is one-third from the bottom of the ladder.

(i) Draw a sketch diagram to show the forces acting on the ladder. (02marks)

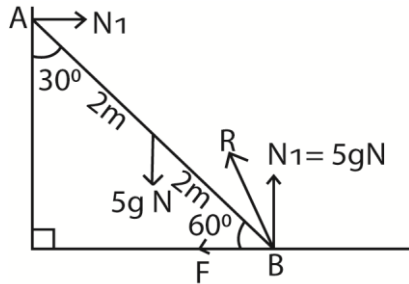

(ii) Find the reaction of the ground on the ladder (04marks)

Taking moments about A;

$$F \times 3 \cos 30^\circ + 5g \times 2 \sin 30^\circ = 5g \times 3 \sin 30^\circ$$

$$F = 9.44\text{N}$$

$$R = \sqrt{9.44^2 + (3 \times 9.91)^2} = 49.95\text{N}$$

$$\theta = \tan^{-1} \left(\frac{9.44}{49.05} \right) = 10.9^\circ \text{ to the vertical}$$

55. (a) (i) Define stress and strain (02marks)

Stress is force per unit area.

Strain is force per unit length

(ii) Determine the dimensions of Young's modulus. (03marks)

$$Y = \frac{\text{stress}}{\text{strain}} = \frac{F}{A} \div \frac{e}{L} = \frac{MLT^{-2}}{L^2} \times \frac{L}{L} = ML^{-1}T^{-2}$$

(b) Sketch a graph of stress versus strain for a ductile material and explain its features. (06marks)

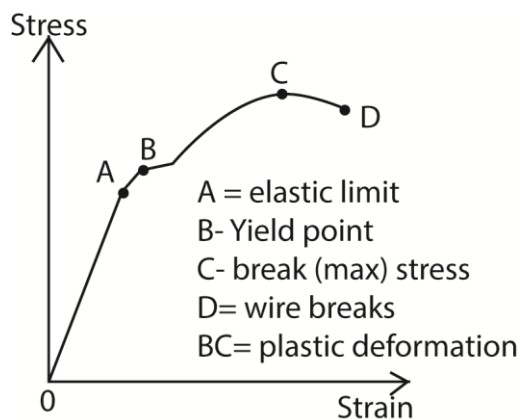

- OA – stress is proportional to strain and the material regains its length
- AB - stress is not proportional to strain but the material regains its length
- Beyond B the material becomes permanently stretched

- CD the material undergoes plastic deformation
- Beyond D the material breaks

(c) A steel wire of cross section area 1mm^2 is cooled from a temperature of 60°C to 15°C .

Find the:

(i) strain (02marks)

$$\text{Strain} = \alpha\Delta\theta = 1.1 \times 10^{-5} \times (60 - 15) = 4.95 \times 10^{-4}$$

(ii) force needed to prevent it from contracting. (03marks)

[Young's Modulus = $2.0 \times 10^{11}\text{Pa}$, Coefficient of linear expansion of steel = $1.1 \times 10^{-5}\text{K}^{-1}$]

Force = $AY\text{strain}$

$$= 10^{-6} \times 2 \times 10^{11} \times 4.95 \times 10^{-4}$$

$$= 99\text{N}$$

(d) Explain the energy changes which occur during plastic deformation (04marks)

During plastic deformation, molecular separation increase leading to a gain in elastic potential energy and heat is evolved. This heat is not recoverable when stress is reduced to zero.

56. (a) (i) State Archimedes' Principle. (01mark)

Archimedes' Principle states that when a body is fully or partially immersed in a fluid, it experiences an up thrust equal to the weight of the fluid displaced.

(ii) Describe an experiment to determine the relative density of an irregular solid which floats in water

- Weigh the solid in air = W
- Attach a sinker to irregular solid and weigh them when the solid is outside but the sinker immersed in water = W_1
- Weigh the solid and the sinker when the both completely immersed in water = W_2 .
- Upthrust on irregular solid in water = $W_1 - W_2$

$$\text{Relative density} = \frac{W}{W_1 - W_2}$$

(iii) A block of wood floats at an interface between water and oil with 0.25 of its volume submerged in oil. If the density of the wood is $7.3 \times 10^2\text{kgm}^{-2}$, find the density of oil. (04marks)

From mass = volume x density

Mass of water displaced = $0.75V \times 1000$ where V = volume of wood

Mass of oil displaced = $0.25V\rho$ where ρ = density of oil

Mass of water displaced + mass of oil displaced = mass of wood

$$0.75V \times 1000 + 0.25V\rho = 7.3 \times 10^2V$$

$$\rho = 80\text{kgm}^{-3}$$

(b) (i) State Bernoulli's Principle. (04marks)

For non- viscous incompressible fluid, flowing steadily, the sum of the pressure, kinetic energy and potential energy per unit volume is constant.

(ii) Explain the origin of the lift force on the wings of an aeroplane at take-off. (04marks)

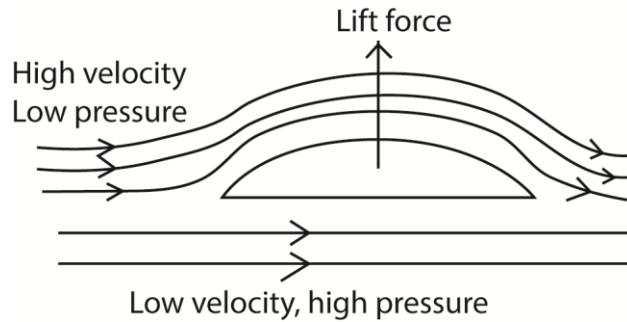

- Air flows above the wing of a plane at high velocity hence low pressure.
- Below the wings, air flows at low velocity and hence high pressure.
- The difference in pressure cause a lift force, therefore net upward force.

(c) Water flowing in a pipe on the ground with a velocity of 8ms^{-1} and at gauge pressure of $2.0 \times 10^5\text{Pa}$ is pumped into a water tank 10m above the ground. The water enters the tank at a pressure of $1.0 \times 10^5\text{Pa}$. Calculate the velocity with which the water enters the tank. (03marks)

From $P + \frac{1}{2}\rho v^2 + \rho gh = \text{constant}$ where P = atmospheric pressure+ gauge pressure

$$3 \times 10^5 + \frac{1}{2} \times 10^3 \times 8^2 + 0 = 1 \times 10^5 + \frac{1}{2} \times 10^3 \times v^2 + 10^3 \times 9.81 \times 10$$

$$V = 16.4\text{ms}^{-1}$$

(d) Describe how terminal velocity can be measured. (04marks)

- A viscous fluid is filled in a tall jar
- A spherical ball is dropped centrally into the fluid and time t taken by the ball to fall through known distance, d, between known points is determined.
- Terminal velocity, $v_0 = \frac{d}{t}$
- The experiment is repeated to obtain average value.

57. (a) Distinguish between scalar and vector quantities giving two example each. (03marks)

- A scalar quantity has magnitude but not direction e.g. volume, mass
- A vector quantity has both magnitude and direction, e.g. velocity, acceleration, displacement, force.

(b) The equation for volume, V, of a liquid flowing through a pipe in time t, under steady

flow is given by $\frac{V}{t} = \frac{\pi r^4 P}{8\eta L}$ where

r = radius of the pipe

P = pressure difference between two point of the pipe

L = length of the pipe

η = coefficient of viscosity of the liquid

If the dimensions of η are $\text{ML}^{-1}\text{T}^{-1}$, show that the above equation is dimensionally consistent.

$$[\text{L.H.S}] = \left[\frac{V}{t} \right] = \text{L}^3\text{T}^{-1}$$

$$[\text{R.H.S}] = \frac{[r^4][P]}{[\eta][L]} = \frac{\text{L}^4 \times \text{MLT}^{-2}\text{L}^{-2}}{\text{ML}^{-1}\text{T}^{-1} \times \text{L}} = \text{L}^3\text{T}^{-1}$$

Since $[\text{L.H.S}] = [\text{R.H.S}]$, the equation is dimensionally consistent.

(c) (i) define linear momentum. (01mark)

Momentum of a body is the product of its mass and velocity

- (ii) State the law of conservation of linear momentum. (01mark)

When bodies in a system interact, the total momentum remains constant provided no external force on the system.

- (iii) Show the law in (c)(ii) above follows from Newton's law of motion. (03marks)

Let bodies A and B collide

From Newton's second law of motion,

$$\text{Force on A due to B, } F_A = \frac{m_a v_a - m_a u_a}{t}$$

$$\text{Force on B due to A, } F_B = \frac{m_b v_b - m_b u_b}{t}$$

From Newton's third law; $F_A = -F_B$

$$\frac{m_a v_a - m_a u_a}{t} = - \frac{m_b v_b - m_b u_b}{t}$$

$$\Rightarrow (m_a v_a - m_a u_a) - (m_b v_b - m_b u_b) = 0$$

- (iv) Explain why, when catching a fast moving ball, the hands are drawn back while the ball is being brought to rest. (02marks)

Drawing hands back allows for a longer time of action reducing force of impact and damage to hands.

- (d) A car of mass 100kg travelling at uniform velocity of 20ms^{-1} collides perfectly inelastically with a stationary car of mass 1500kg. Calculate the loss in kinetic energy of the car as a result of the collision. (04marks)

$$m_1 u_1 = (m_1 + m_2)v$$

$$v = \frac{m_1 u_1}{(m_1 + m_2)} = \frac{1000 \times 20}{2500} = 8\text{ms}^{-1}$$

$$\begin{aligned} \text{loss in K.E} &= \frac{1}{2} m_1 u^2 - \frac{1}{2} (m_1 + m_2) v^2 \\ &= \frac{1}{2} \times 1000 \times 20^2 - \frac{1}{2} \times 2500 \times 8^2 \\ &= 1.2 \times 10^5 \text{J} \end{aligned}$$

- (e) (i) What is meant by conservation of energy? (01mark)

Energy changes from one form to another, the total amount of energy after the change must be equal to the initial amount of energy.

- (ii) Explain how conservation of energy applies to an object **falling** from rest in a vacuum. (02marks)

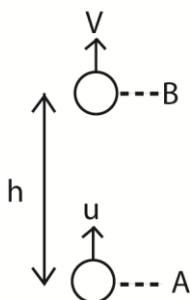

At A, K.E = $\frac{1}{2}mu^2$, P.E = 0

Total energy at A = K.E + P.E = $\frac{1}{2}mu^2 + 0 = \frac{1}{2}mu^2$

At B, K.E = $\frac{1}{2}mv^2$; P.E = mgh

Total energy at B, = $\frac{1}{2}mv^2 + mgh$

But $v^2 = u^2 - 2gh$

Total energy at B = $\frac{1}{2}m(u^2 - 2gh) + mgh = \frac{1}{2}mu^2$

∴ Total energy at A = total energy at B

58. (a) Explain the term

(i) Ductility (01mark)

Ductility is the ability of a material to be transformed into different shapes without crumbling

(ii) Stiffness (01mark)

Stiffness is the ability of a material to oppose change in shape

(b) A copper wire and steel wire each of length 1.0m and diameter 1.0mm are joined end to end to form a composite wire 2.0m long. Find the strain in each when the composite stretches by 2.0×10^{-3} m.

[Young's Modulus for copper and steel are 1.2×10^{11} Pa and 2.0×10^{11} Pa respectively]
(07marks)

$$F_1 = k_1e_1; \quad F_2 = k_2e_2$$

$$\text{But } F_1 = F_2$$

$$\therefore k_1e_1 = k_2e_2 \Rightarrow e_1 = \frac{k_2e_2}{k_1} = \frac{Y_2e_2}{Y_1} = \frac{2 \times 10^{11}}{1.2 \times 10^{11}}e_2 = 2 \times 10^{-3}$$

$$e_2 = 0.75 \times 10^{-3} \text{ m}$$

$$\text{strain in steel wire} = \frac{e_2}{l_2} = \frac{0.75 \times 10^{-3}}{1} = 0.75 \times 10^{-3}$$

$$e_1 = 1.25 \times 10^{-3} \text{ m}$$

$$\text{Strain in copper wire} = \frac{e_1}{l_1} = \frac{1.25 \times 10^{-3}}{1} = 1.25 \times 10^{-3}$$

(c) (i) Define centre of gravity (01mark)

Centre of gravity is the point through which the gravitational forces act.

(ii) Describe an experiment to find the centre of gravity of a flat irregular piece of cardboard. (03marks)

- three holes are drilled around the edge of the sheet of irregular object.
- The cardboard is suspended from a pin through one of the holes. When the cardboard is freely suspended, a plumb line is suspended from the same pin.
- A line is drawn to mark the line where the plumb line passes.
- The procedure is repeated for the other two holes.

(d) Explain the laws of solid friction using molecular theory (07marks)

- The frictional force between two surfaces opposes their relative motion, this because the actual area of contact between solid surfaces is very small. Therefore pressure at points of contact is very high; projections emerge to produce adhesion or welding. The force which oppose motion is obtained
- The frictional force is independent of the area of contact of the given surfaces when the normal reaction is constant, because the actual area of contact is the sum of the areas of tiny projections that adhere to each other and are nearly independent of the surface areas of contact.
- The limiting frictional force is proportional to the normal reaction for the case of static friction. The frictional force is proportional to the normal reaction for the case of kinetic (dynamic) friction, and is independent of the relative velocity of the surfaces. This is because increase in weight increases the actual area of contact and hence greater limiting frictional force.

59. (a) What is meant by the following terms?

(i) Velocity gradient. (01mark)

Velocity gradient is the change of velocity between two points per unit length of separation of the points.

Or

It is the rate of change of velocity with change in distance of separation.

(ii) Coefficient of viscosity (01mark)

Coefficient of viscosity is the tangential force per unit area of fluid which resists the motion of one layer over another in a region of unit velocity gradient.

(b) Derive an expression for terminal velocity of a steel ball-bearing of radius, r , and density, ρ , falling through a liquid of density, σ , and coefficient of viscosity, η . (05marks)

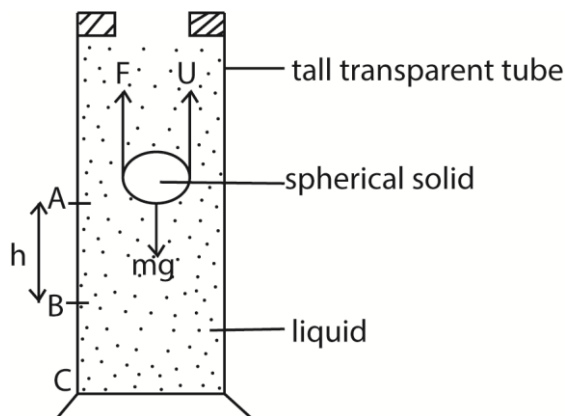

- A liquid of known density, ρ , is put in a tall transparent glass with reference marks A and B, h metres apart
- A spherical solid of radius a and density, σ , is dropped into the liquid and time t taken to drop from A to B is determined.
- Terminal velocity, $v_0 = \frac{h}{t}$

$$\text{The coefficient viscosity, } \eta = \frac{2r^2(\sigma - \rho)g}{9v_0}$$

Assumptions

The spherical solid moves with terminal velocity by the time it reaches A

Precautions

- The glass tube should be very wide compared to the diameter of the ball.
- The point C should be far away from the top of the tube
- Temperature is constant

(c) (i) Define surface tension (01mark)

Is the force acting at right angle at one side of imaginary line of length 1m drawn in the surface of a liquid.

(ii) Explain the origin of surface tension. (03marks)

- Liquid molecules attract each other.
- The molecules within the body of the liquid (bulk) molecules is attracted equally by neighbors in all direction, hence, the force on the bulk molecules is zero,
- For a surface molecule, there is a net inward force because there are no molecules above the surface to attract them equally.
- To the surface, work must be done against the inward attractive force, hence, a molecule in the surface of a liquid has a greater potential energy than a molecule in the bulk. The potential energy stored in molecules at the surface is called free surface energy or surface tension.
- Due to the attractive forces experienced by surface molecules due to their neighbours put in a state of tension; the liquid surface behave as a stretched skin.

(iii) Describe an experiment to measure surface tension of a liquid by capillary method. (06marks)

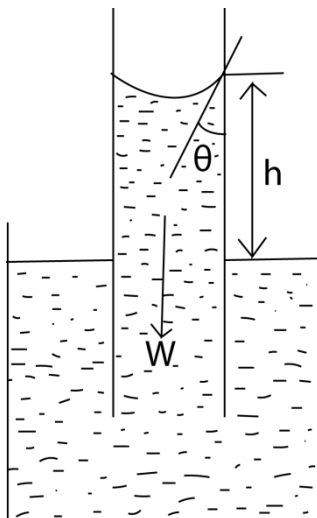

The liquid rises until the vertical component of the upward forces due to surface tension is equal to the weight of the liquid column.

$$F\gamma\cos\theta = W$$

$$\gamma = \frac{F}{L}$$

$$F = \gamma L$$

$$L = 2\pi r$$

But $W = mg$ and $m = V\rho$ (where ρ is the density of the liquid in kg/m^3)

$$W = v\rho g = 2\pi r^2 h\rho g$$

$$F\gamma\cos\theta = 2\pi r^2 h\rho g$$

$$\gamma \cdot 2\pi r \cos\theta = 2\pi r^2 h\rho g$$

$$h = \frac{2\gamma \cos\theta}{r\rho g}$$

γ – coefficient of surface tension

θ – angle of contact

r – radius of capillary tube

ρ – density of the liquid

- (d) Explain, with the aid of a diagram why air-flow over the wings of an aircraft at take-off cause a lift. (03marks)

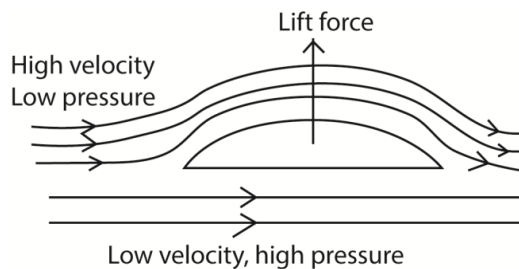

- Air flows above the wing of a plane at high velocity hence low pressure.
- Below the wings, air flows at low velocity and hence high pressure.
- The difference in pressure cause a lift force, therefore net upward force.

60. (a) (i) Define angular velocity. (01marks)

Angular velocity is the rate of change of angle of rotation of an object moving in a circular path about the centre.

- (ii) Derive an expression for the force, F , on a particle of mass, m , moving with angular velocity, ω , in a circle of radius, r . (03marks)

$$F = ma = \frac{mv^2}{r} \text{ since } a = \frac{v^2}{r}$$

$$\text{But } v = \omega r$$

$$\therefore F = \frac{m(\omega r)^2}{r} = m\omega^2 r$$

- (b) A stone of mass 0.5kg is attached to a string of length 0.5m which will break if the tension in it exceeds 20N. The stone is whirled in a vertical circle, the axis of rotation being at a vertical height of 1.0m above ground. The angular speed is gradually increased until the string breaks.

- (i) In what position is the string most likely to break? (02marks)

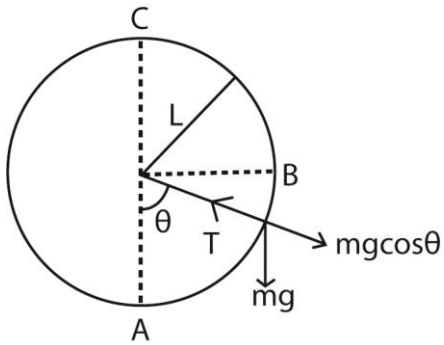

At A, $\theta = 0$

$$\Rightarrow T = \frac{mv^2}{L} + mg$$

At B, $\theta = 90^\circ$

$$\Rightarrow T = \frac{mv^2}{L}$$

At C, $\theta = 180^\circ$

$$\Rightarrow T = \frac{mv^2}{L} - mg$$

The string breaks at the lowest point, A of the circle because tension the string is highest.

(ii) At what angular speed will the string break? (03marks)

String breaks $T = m\omega^2 r + mg$

$$20 = 0.5 \times 0.5 \times \omega^2 + 0.5 \times 9.81$$

$$\Omega = 7.77 \text{ rad s}^{-1}$$

$$v = \omega r = 7.77 \times 0.5 = 3.9 \text{ m s}^{-1}$$

(iii) Find the position where the stone hits the ground when the string breaks. (03marks)

Vertical distance to be covered = 0.5m

$$s = ut + \frac{1}{2}at^2$$

but initial component of vertical velocity = 0

$$\Rightarrow 0.5 = \frac{1}{2} \times 9.81 \times t^2$$

$$t = 0.3 \text{ s}$$

$$\text{Horizontal distance} = 3.9 \times 0.3 = 1.17 \text{ m}$$

(c) Explain briefly the action of a centrifuge. (03marks)

Consider a body falling through a viscous fluid. For small speed, the liquid opposes motion with a resisting force, f , proportional to the velocity, v .

$f = kv$ where k is a constant of proportionality.

At terminal velocity, $v_t = \frac{mg}{k}$

If a container is whirled at high speed, the particles will move approximately in circles with speed, v , and acceleration = $\frac{v^2}{r}$.

When they reach their terminal velocity, v_t , relative to the fluid, the resisting force of the fluid on the particle, $f = kv_t$ must be equal to the mass of the particle multiplied by its acceleration such that the terminal velocity, v_t of the particles relative to the fluid is given by $v_t = \frac{mv^2 + r}{k}$

The terminal speed or sedimentation rate is increased by a factor of $\frac{v^2}{rg}$ which may be in thousands.

Centrifuges are used to separate cream from milk, silt from river water, blood cells from plasma, e.t.c

(d) Describe how the acceleration due to gravity can be measured using helical spring of unknown force constant, and the other relevant apparatus. (05marks)

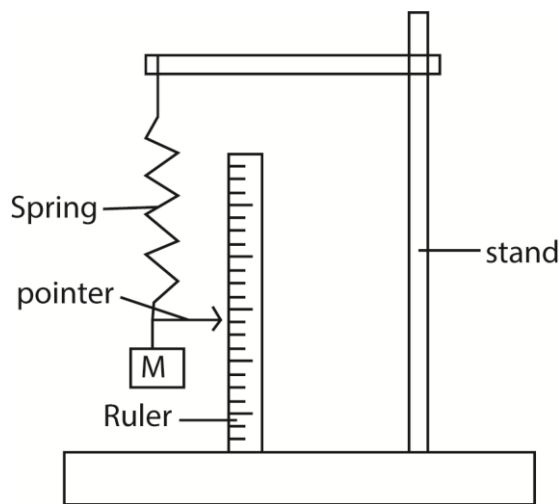

- Suspend a spiral spring from the clamp of a retort stand.
- Attach the pointer to the free end of the spring such that it is horizontal.
- Read and record the initial pointer position on a meter rule supported vertically.
- Suspend a mass, m , from the spring and record the new position of the pointer and calculate the extension, x , of the spring
- Displace the mass, m , through a small vertical distance and release it.
- Measure the time for a reasonable number of oscillations
- Calculate the period T of oscillations. Repeat the procedure for different value of masses.
- Plot a graph of T^2 against x , and find the slope, S , of the graph
- Calculate g from $g = \frac{4\pi^2}{S}$

61. (a) State the laws of friction (04marks)

- Friction force oppose relative motion between surfaces in contact.
- Friction force is independent of area of contact provided normal reaction is constant.
- The friction force is directly proportional to the normal reaction.

- (b) A block of mass 5.0kg resting on the floor is given a horizontal velocity of 5.0ms⁻¹ and comes to rest in a distance of 7.0m. Find the kinetic friction between the block and the floor. (04marks)

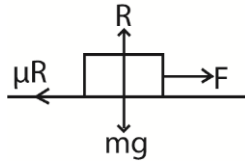

$$\text{From } v^2 = u^2 + 2as$$

$$0 = 5^2 - 2a \times 7$$

$$a = 1.79\text{ms}^{-1}$$

$$F = ma = 5 \times 1.79 = 8.95\text{N}$$

$$R = mg = 5 \times 9.81 = 49.05\text{N}$$

Also friction force, $F = \mu R$

$$\mu = \frac{F}{R} = \frac{8.95}{49.05} = 0.18$$

- (c) (i) State the law of conservation of linear momentum (01mark)

The law of conservation of momentum states that if no external force acts on a system of colliding objects, the total momentum of the objects in a given direction is constant.

- (ii) What are perfectly inelastic collision? (01mark)

Two bodies are said to be perfectly inelastic after collision if

- Momentum is conserved while kinetic energy is not conserved
- The bodies stick together and move with common velocity.
- Coefficient of restitution is equal to zero.

- (d) A car of 1500kg rolls from rest down a road inclined to the horizontal at an angle 35°, through 50m. The car collides with another car of identical mass at the bottom of the incline. If the two cars interlock on collision, and the coefficient of kinetic friction is 0.20, find the common velocity of the vehicles. (08marks)

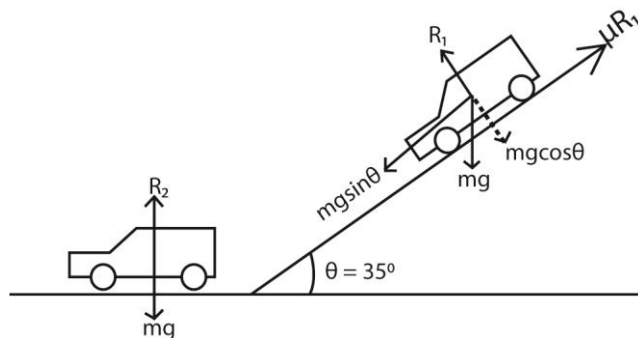

$$\text{For the vehicle } ma = mg \sin \theta - \mu R_1$$

$$ma = mg \sin \theta - \mu mg \cos \theta$$

$$a = 9.81 \sin 35^\circ - 0.2 \times 9.81 \cos 35^\circ$$

$$= 4\text{ms}^{-2}$$

The velocity of the first car before collision

$$v^2 = u^2 + 2as$$

$$v^2 = 0 + 2 \times 4 \times 50$$

$$v = 20\text{ms}^{-1}$$

Horizontal component of velocity, $u_1 = 20 \cos 35^\circ = 16.4\text{ms}^{-1}$

After collision, momentum conserved.

$$m_1 u_1 = (m_1 + m_2) v$$

$$v = \frac{1500 \times 16.4}{(1500 + 1500)} = 8.2 \text{ ms}^{-1}$$

(e) Discuss briefly the energy transformation which occur in (d) above

The potential energy of the car on the slope is converted to kinetic energy and heat due to friction. Then the kinetic energy is converted to sound and heat due to friction.

62. (a) Define angular velocity (01mark)

Angular velocity is the rate of change of the angle of rotation for an object moving in a circular path about the centre.

(b) A car of mass, m , travels round a circular track of radius, r , with velocity, V .

(i) Sketch a diagram to show the forces acting on the car. (02marks)

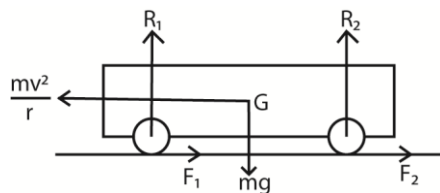

(ii) Show that the car does not overturn if $V^2 < \frac{arg}{2h}$, where a is the distance between the wheels, h , is the height of the centre of gravity above the ground and g is acceleration due to gravity. (05marks)

Suppose the car is moving with velocity, v , around a horizontal circular track of radius, r . if m is the mass of the car and R_1 and R_2 are normal reactions at the inner and outer wheels respectively and F_1 and F_2 are the corresponding frictional forces, then for circular motion:

$$F_1 + F_2 = \frac{mv^2}{r} \dots\dots\dots (i)$$

For vertical equilibrium

$$R_1 + R_2 = mg \dots\dots\dots(ii)$$

Taking moments about G

Clockwise moments = anticlockwise moments

$$(F_1 + F_2)h + R_1 \frac{a}{2} = R_2 \frac{a}{2}$$

$$(F_1 + F_2)h = \frac{a}{2} (R_2 - R_1) = \dots\dots\dots (iii)$$

Substituting Eqn. (i) into Eqn. (iii)

$$\frac{mv^2 h}{r} = \frac{a}{2} (R_2 - R_1) \dots\dots\dots(iv)$$

From (ii)

$$R_1 = mg - R_2$$

From equation (iv)

$$\frac{mv^2h}{r} = \frac{a}{2} (R_2 - (mg - R_2)) = \frac{a}{2} (2R_2 - mg)$$

$$2R_2 = \frac{2mv^2h}{ar} + mg = m\left(\frac{2v^2h}{ar} + g\right)$$

$$R_2 = \frac{m}{2} \left(\frac{2v^2h}{ar} + g\right)$$

$$\text{Also } R_2 = mg - R_1$$

From equation (iv)

$$\frac{mv^2h}{r} = \frac{a}{2} ((mg - R_1) - R_1) = \frac{a}{2} (mg - 2R_1)$$

$$2R_1 = mg - \frac{2mv^2h}{ar}$$

$$R_1 = \frac{m}{2} \left(g - \frac{2v^2h}{ar}\right)$$

When the car is about to overturn, $g = \frac{2v^2h}{ar}$, $R_1 = 0$, $v^2 = \frac{gar}{2h}$

- (c) A pendulum bob of mass 0.2kg is attached to one end of an inelastic string of length 1.2m. The bob moves in a horizontal circle with the string inclined at 30° to the vertical. Calculate

- (i) the tension in the string (02marks)

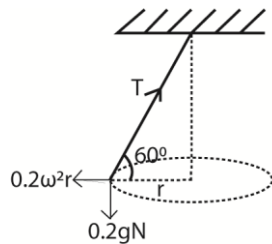

Resolving vertically

$$T \sin 60^\circ = 0.2g = 0.2 \times 9.81$$

$$T = 2.27 \text{ N}$$

- (ii) the period of motion (04marks)

$$T \cos 60^\circ = 0.2\omega^2 r; \omega = \frac{2\pi}{T}; r = 1.2 \cos 60^\circ = 0.6 \text{ m}$$

$$2.27 \cos 60^\circ = 0.2 \times \frac{4\pi^2}{T^2} \times 0.6$$

$$\text{Period, } T = 2.04 \text{ s}$$

- (d) Explain and sketch the variation of acceleration due to gravity with distance from the centre of the earth (06marks)

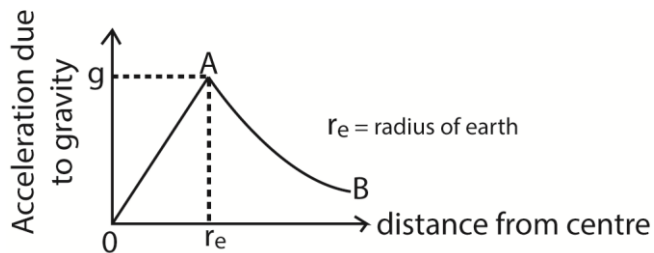

- Inside the earth, assuming uniform density, the acceleration due to gravity varies linearly with distance from the centre.
- For points outside the earth, the acceleration due to gravity varies inversely as the square distance from the centre. i.e. $g \propto \frac{1}{r^2}$ where r is the distance from the surface of the earth. Therefore outside the earth gravity decreases with height.

63. (a) (i) What is meant by simple harmonic motion? (01mark)

Simple harmonic motion is a periodic motion whose acceleration is directed towards a fixed point and is proportional to the displacement from the fixed point.

(ii) Show with the aid of a suitable sketch graph how kinetic energy of a mass attached at the end of an oscillating light spring changes with distance from equilibrium position. (04marks)

$$\text{Kinetic energy} = \frac{1}{2}mv^2; \text{ but } v = \pm\omega\sqrt{a^2 - x^2}$$

$$\Rightarrow \text{K.E} = \frac{1}{2}m\omega^2(a^2 - x^2)$$

This yields the following graph

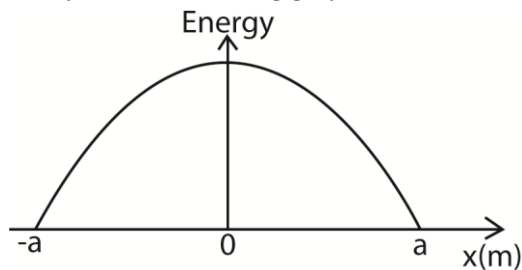

(b)

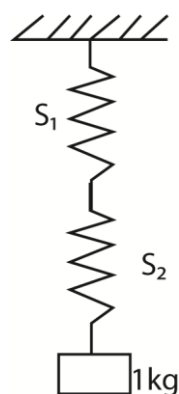

A mass of 1.0kg is hang from two springs S_1 and S_2 connected in series as shown above.

The force constant of the springs are 100Nm^{-1} and 200Nm^{-1} respectively. Find

(i) The extension produced in combination. (04marks)

At equilibrium the tension in each spring = $T = mg$

$$\Rightarrow k_1 e_1 = mg$$

$$100 \times e_1 = 1 \times 9.81$$

$$e_1 = 9.81 \times 10^{-2} \text{m}$$

Also;

$$k_2 e_2 = mg$$

$$200 \times e_2 = 1 \times 9.81$$

$$e_2 = 4.905 \times 10^{-2} \text{m}$$

$$\text{Total extension} = e_1 + e_2 = (9.81 + 4.905) \times 10^{-2} \text{m} = 0.14715 \text{m}$$

- (ii) The frequency of oscillation of the mass if it is pulled downwards through a small distance and released. (06marks)

$$T = 2\pi \sqrt{\frac{e}{g}} = 2\pi \sqrt{\frac{0.14715}{9.81}} = 0.77 \text{s}$$

$$f = \frac{1}{T} = \frac{1}{0.77} = 1.3 \text{Hz}$$

- (c) Explain with the aid of a sketch graph, what would happen to the oscillations in (b)(ii) above if the mass was immersed in a liquid such as water. (04marks)

If the mass is immersed in water, the amplitude decreases until the oscillations die away due to loss of energy arising from friction.

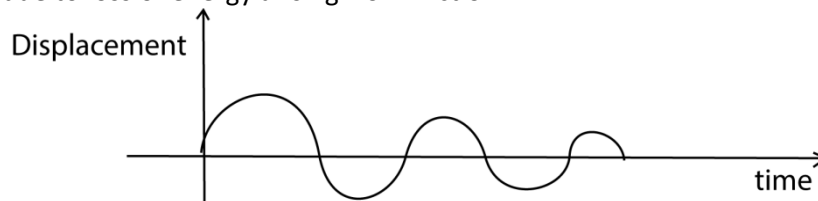

64. (a) (i) Define gravitational field strength. (01mark)

The gravitational field strength at any point in gravitational field is the gravitational force experienced by a unit mass placed at that point provided that the unit mass itself does not cause any change in the field

- (ii) Draw a sketch graph to show how the gravitational field strength varies with height, h , above the earth's surface. (02marks)

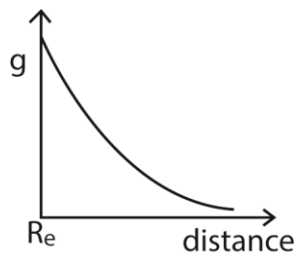

- (b) The period of simple pendulum is measured at different locations along a given longitude. Explain what is observed. (06marks)

From the equator towards the pole along a longitude the radius of the earth, R_e , decreases.

$$\text{Since } mg = \frac{GMm}{R_e^2} \Rightarrow g \propto \frac{1}{R_e^2}$$

Therefore, g increases towards the pole.

$$\text{From period, } T = 2\pi \sqrt{\frac{l}{g}} \Rightarrow T \propto \frac{1}{\sqrt{g}}$$

Therefore, Period T decrease from the equator towards the pole

- (c) Derive the expression for the escape velocity of a rocket fired from earth. (03marks)

The work done in moving a body of mass, m, from the surface of the earth to infinity is given by

$$W = -\frac{GMm}{\infty} - \frac{-GMm}{R} \text{ but } \frac{GMm}{\infty} = 0$$

$$= \frac{GMm}{R}$$

$$\Rightarrow \frac{1}{2}mv^2 \geq \frac{GMm}{R}$$

$$v = \sqrt{\frac{2GM}{R}} \text{ where } r \text{ is the radius of the earth}$$

- (d) The rings of the planet Saturn consist of a vast number of small particles, each in a circular orbit about the planet. Calculate the speed of the particles nearest to Saturn if its mass is 6.0×10^{26} kg (04marks)

Centripetal force = Gravitational force of attraction between the planet and the particle.

$$\Rightarrow \frac{GMm}{r^2} = \frac{mv^2}{r}$$

$$v = \sqrt{\frac{GM}{r}} = \sqrt{\frac{6.67 \times 10^{-11} \times 6.0 \times 10^{26}}{r}} = \frac{2.0 \times 10^8}{\sqrt{r}}$$

- (e) The moon moves in a circular orbit of radius 3.84×10^8 m around the earth with a period of 2.36×10^5 s. Calculate the gravitational field of the earth at the moon. (04marks)

If r_e and r_0 are the radii of the earth and the moon's orbit around the earth respectively, and g' is the gravitational field strength of the earth at the moon;

$$\text{From } g \propto \frac{1}{r^2}$$

$$g \propto \frac{1}{r_e^2} \text{ also } g' \propto \frac{1}{r_0^2}$$

$$\Rightarrow \frac{g'}{g} \propto \frac{r_e^2}{r_0^2}$$

$$g' = \frac{(6.4 \times 10^6)^2}{(3.84 \times 10^8)^2} \times 9.81 = 2.73 \times 10^{-3} \text{ms}^{-2}$$

65. (a) Distinguish between fundamental and derived physical quantities. Give two examples of each. (04marks)

Fundamental quantities are those physical quantities which cannot be expressed in terms of other quantities using mathematical equations. They include mass (M), length (L) and time (T).

Derived quantities are those physical quantities which can be expressed in terms of fundamental quantities, e.g., density, velocity, pressure.

- (b) (i) What is meant by scalar and vector quantities? (02marks)

A **scalar** is a physical quantity with magnitude but no direction.

A **vector** is a physical quantity with both magnitude and direction.

- (ii) A ball is thrown vertically upwards with a velocity 10m^{-1} from a point 3.0m above ground. Describe with the aid of a velocity-time sketch graph, the subsequent motion of the ball. (10marks)

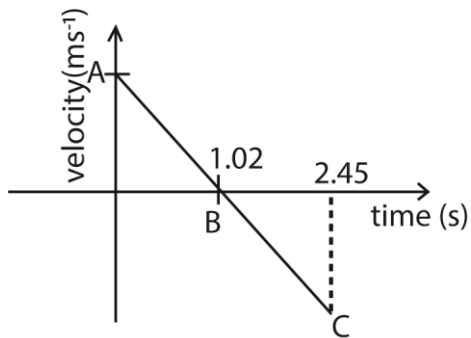

The body is projected at A, rises with uniform acceleration up to B which is at a vertical height, h , from the point of projection. At B, $v = 0$

$$\text{From } v^2 = u^2 + 2as$$

$$0 = 10^2 - 2 \times 9.81h$$

$$h = 5.1\text{m}$$

the time taken to cover the height, h , is obtained from; $v = u + at$

$$0 = 10 - 9.81t$$

$$t = 1.02\text{s}$$

From B, the ball falls with uniform acceleration and if it takes time, t s to strike C.

$$\text{From } y = ut + \frac{1}{2}at^2$$

$$-5 = 10t - 4.9t^2$$

$$t = 2.45\text{s}$$

Velocity at C

$$\text{From } v^2 = u^2 + 2as$$

$$v^2 = 0 + 2 \times 9.81 \times 10.1$$

$$v = 14.1\text{ms}^{-2}$$

(c) A boat crosses a river 3km wide flowing at 4ms^{-1} to reach a point on the opposite bank 5km upstream. The boat's speed in still water is 12ms^{-1} . Find the direction in which the boat must be headed. (04marks)

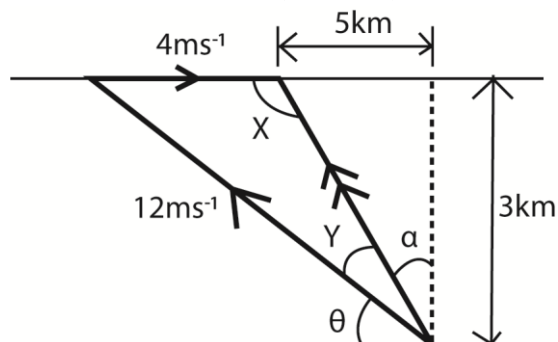

$$\alpha = \tan^{-1} \frac{5}{3} = 59.04^\circ$$

$$X = 90 + 59.04 = 149.04$$

Applying the sine rule to the vector triangle OQR

$$\frac{\sin Y}{4} = \frac{\sin 149.04}{12}; Y = 9.87^\circ$$

$$\text{But } \theta + Y + \alpha = 90^\circ$$

$$\theta = (90 - 9.87 - 59.04) = 21.09^\circ$$

therefore the boat should be steered in a direction making of 21.08° to the river up stream

66. (a) Define the following terms:

- (i) Angular velocity (01mark)
Angular velocity is the rate of change of the angle swept out by the radius joining a body to the centre of circular path.
- (ii) Centripetal acceleration (01mark)
Centripetal acceleration is the rate of change of velocity for a body describing a circular path and is always directed towards the centre of the path.

(b) (i) Explain why a racing car can travel faster on a banked road than on flat track of the same curvature. (04marks)

(ii) Derive an expression for the speed with which a car can negotiate a bend on a banked track without skidding. (03marks)

- **On a flat track**

For Suppose the car is moving with velocity, v , around a horizontal circular track of radius, r . if m is the mass of the car and R_1 and R_2 are normal reactions at the inner and outer wheels respectively and F_1 and F_2 are the corresponding frictional forces, then for circular motion:

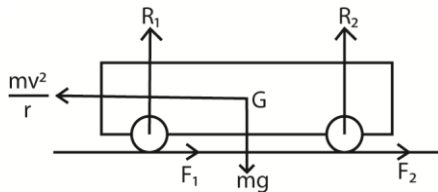

$$F_1 + F_2 = \frac{mv^2}{r} \dots\dots\dots (i)$$

For vertical equilibrium

$$R_1 + R_2 = mg \dots\dots\dots(ii)$$

Taking moments about G

Clockwise moments = anticlockwise moments

$$(F_1 + F_2)h + R_1 \frac{a}{2} = R_2 \frac{a}{2} \text{ (a = distance between the wheels, h = the height of the centre of gravity from the ground)}$$

$$(F_1 + F_2)h = \frac{a}{2} (R_2 - R_1) = \dots\dots\dots (iii)$$

Substituting Eqn. (i) into Eqn. (iii)

$$\frac{mv^2 h}{r} = \frac{a}{2} (R_2 - R_1) \dots\dots\dots(iv)$$

From (ii)

$$R_1 = mg - R_2$$

From equation (iv)

$$\frac{mv^2 h}{r} = \frac{a}{2} (R_2 - (mg - R_2)) = \frac{a}{2} (2R_2 - mg)$$

$$2R_2 = \frac{2mv^2h}{ar} + mg = m\left(\frac{2v^2h}{ar} + g\right)$$

$$R_2 = \frac{m}{2}\left(\frac{2v^2h}{ar} + g\right)$$

Also $R_2 = mg - R_1$

From equation (iv)

$$\frac{mv^2h}{r} = \frac{a}{2}((mg - R_1) - R_1) = \frac{a}{2}(mg - 2R_1)$$

$$2R_1 = mg - \frac{2mv^2h}{ar}$$

$$R_1 = \frac{m}{2}\left(g - \frac{2v^2h}{ar}\right)$$

When the car is about to overturn, $g = \frac{2v^2h}{ar}$, $R_1 = 0$, $v^2 = \frac{gar}{2h}$

The maximum velocity of a car to negotiate a bend of radius r on a flat track, $v = \sqrt{\frac{gar}{2h}}$

- On banked ground

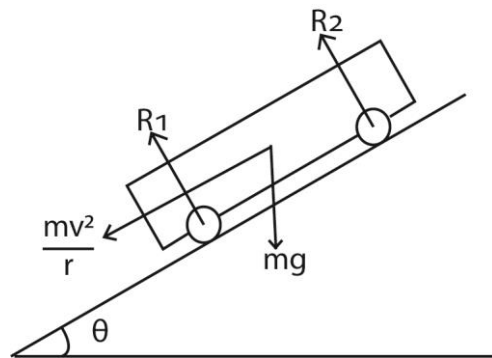

Resolving horizontally

$$(R_1 + R_2) \sin \theta = \frac{mv^2}{r} \dots\dots\dots (i)$$

Resolving vertically;

$$(R_1 + R_2) \cos \theta = mg \dots\dots\dots (ii)$$

Divide equation (i) by Eqn. (ii)

$$\tan \theta = \frac{v^2}{rg}$$

$$v = \sqrt{rg \tan \theta}$$

(c) a Show how to estimate the mass of the sun if the period and radius of one of its planets are known. (03marks)

Suppose the sun of mass M and a planet has the mass, m , in a circular orbit of radius, r

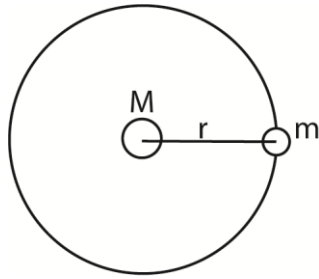

The centripetal force is provided by the gravitational force between the sun and the planet.

$$\Rightarrow \frac{GMm}{r^2} = \frac{mv^2}{r}$$

$$M = \frac{v^2 r}{G}; \text{ but } v = \omega r = \left(\frac{2\pi}{T}\right) r$$

$$M = \frac{4\pi^2 r^3}{GT^2}$$

So if r and T are known, the mass of the sun M can be calculated.

- (d) The gravitational potential, U , at the surface of a planet of mass M and radius R is given by $U = -\frac{GM}{R}$, where G is gravitational constant.

Derive an expression for the lowest velocity, V , which an object of mass, m , must have at the surface of the planet if it is to escape from the planet. (04marks)

$$W = -\frac{GMm}{\infty} - \frac{-GMm}{R} \text{ but } \frac{GMm}{\infty} = 0$$

$$= \frac{GMm}{R}$$

$$\Rightarrow \frac{1}{2}mv^2 \geq \frac{GMm}{R}$$

$$v = \sqrt{\frac{2GM}{R}} \text{ where } r \text{ is the radius of the earth and } v \text{ is the velocity of projection}$$

- (e) Communication satellites orbit the earth in synchronous orbits. Calculate the height of communication satellite above the earth. (04marks)

If the satellite has a mass, m , and moves in an orbit of radius, r , about the earth of mass M , then

$$\frac{GMm}{R} = \frac{mv^2}{r} \text{ but } v = \omega r = \left(\frac{2\pi}{T}\right) r$$

$$r = \sqrt[3]{\frac{GMT^2}{4\pi^2}} \text{ but } GM = gr_e^2$$

$$r = \sqrt[3]{\frac{gr_e^2 T^2}{4\pi^2}} = \sqrt[3]{\frac{9.81 \times (6.4 \times 10^6)^2 \times (24 \times 60 \times 60)^2}{4\pi^2}} = 4.24 \times 10^7 \text{ m}$$

$$\text{Hence height above the earth} = (4.24 \times 10^7 - 6.4 \times 10^6) = 3.6 \times 10^7 \text{ m}$$

67. (a) State the law of floatation. (01mark)

The law of floatation state that a floating body displaces its own weight of the fluid in which it floats

(b) With the aid of a diagram, describe how to measure the relative density of a liquid using Archimedes' Principle of moments (06marks)

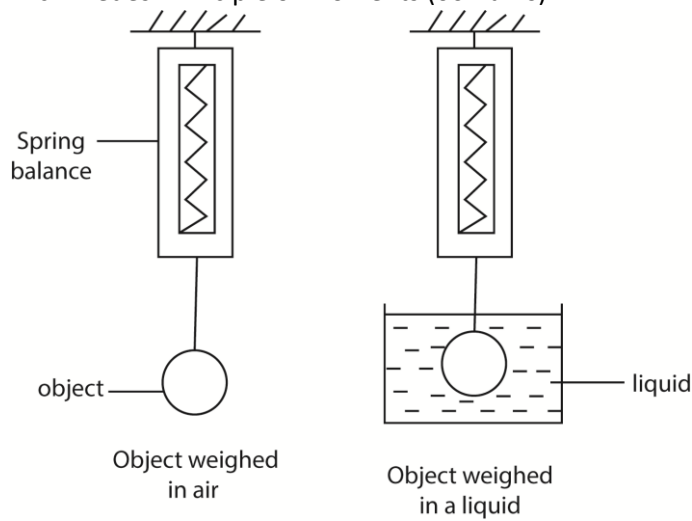

- A solid is weighed in air = M g
- Then a solid s weighed when totally immersed in a liquid whose relative density is required = m_1 g
- Then a solid s weighed when totally immersed in water = m_2 g

Calculations

$$\text{Upthrust in the liquid} = M - m_1$$

$$\text{Upthrust in water} = M - m_2$$

$$\text{Relative density of the liquid} = \frac{M - m_1}{M - m_2}$$

$$\text{Or density of the liquid} = \left(\frac{M - m_1}{M - m_2} \right) \times \text{density of water}$$

(c) A cross sectional area of a ferry at its water-line is 720m^2 .if sixteen cars of average mass 1100kg are placed on board, to what extra depth will the boat sink in the water?

(04marks)

Let the extra depth be x ;

$$\text{From } \rho = \frac{m}{V}; \Rightarrow m = \rho V; \text{ but } V = 720x$$

$$\therefore 1000 \times 720x = 16 \times 110$$

$$x = 0.034\text{m}$$

(d) (i) Define longitudinal stress and Young's Modulus of elasticity. (02marks)

Longitudinal stress is the force acting on a cross-section area of 1m^2 .

(ii) Describe how to determine Young's Modulus for steel wire. (07marks)

Experiment to determine Young's Modulus for a metal wire

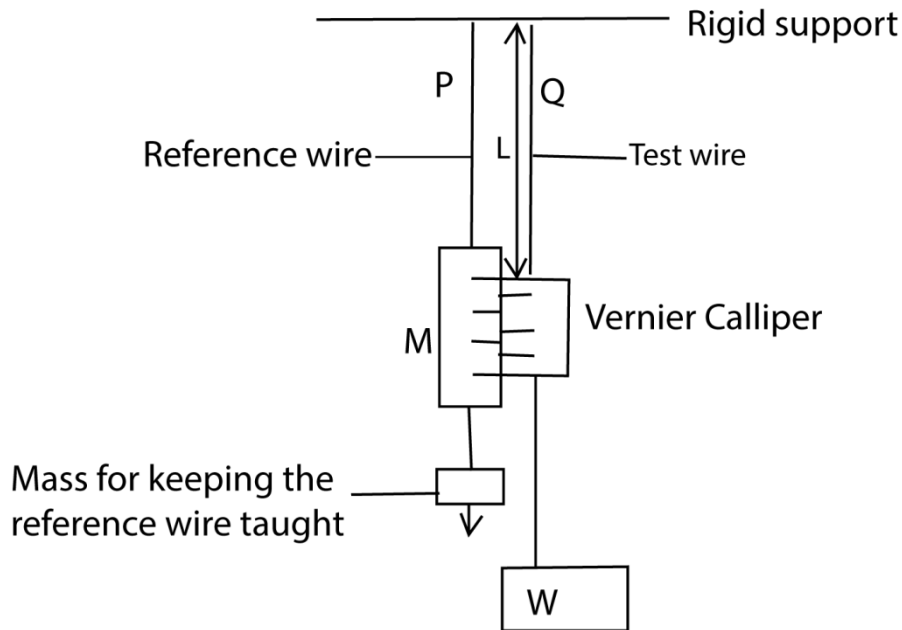

- (vii) Two thin, long wires of the same material and length P and Q are suspended from a rigid support.
- (viii) P carries a scale M in mm and it's straightened by attaching a weight at its end.
- (ix) Q carries a Vernier scale which is alongside scale M
- (x) Various loads are added to the test wire and corresponding extensions caused are read off from a vernier scale.
- (xi) The diameter ($2r$) of the wire is obtained by a micrometre screw gauge, and the cross section area of the wire $A = 4\pi r^2$
- (xii) A graph of mass (m) of the load against extension e is plotted

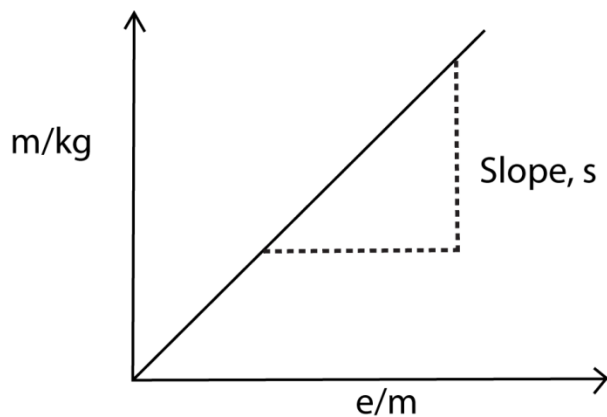

Young's modulus, $Y = \frac{gsL}{A}$

68. (a) A mass of 0.1kg is suspended from a light spring of force constant 24.5Nm^{-1} . Calculate the potential energy of the mass. (04marks)
- Elastic potential energy, $P.E = \frac{1}{2} kx^2$ (i)
- From Hooke's law, $mg = kx$
- $\Rightarrow x = \frac{mg}{k}$ (ii)
- Substituting eqn. (ii) in eqn. (i)

$$P.E = \frac{(mg)^2}{2k} = \frac{(0.1 \times 9.81)^2}{2 \times 24.5} = 1.96 \times 10^{-2} \text{J}$$

(b) (i) State four characteristics of simple harmonic motion. (04marks)

- The acceleration is always directed towards a fixed point in the motion line
- The acceleration is directly proportional to the displacement from a fixed point
- It is periodic
- Total mechanical energy is conserved.

(ii) Show that the speed of a body moving with simple harmonic motion of angular velocity, ω , is given by $V = \omega(A^2 - x^2)^{1/2}$, where A is the amplitude and x is the displacement from equilibrium position. (04marks)

If x is the displacement, from $a = -\omega^2 x$

$$a = \frac{dv}{dt} = \frac{dv}{dx} x \frac{dx}{dt} = V \frac{dv}{dx}$$

$$\Rightarrow V \frac{dv}{dx} = -\omega^2 x$$

$$\int v dv = -\omega^2 \int x dx$$

$$\frac{v^2}{2} = -\frac{\omega^2 x^2}{2} + c \dots\dots\dots (i)$$

But $x = A, v = 0$

$$\Rightarrow c = \frac{\omega^2 A^2}{2}$$

Substituting c in eqn.(i)

$$V^2 = \omega^2(A^2 - x^2)$$

Or

$$V = \omega(A^2 - x^2)^{1/2},$$

(iii) Sketch graphs to show the variation with displacement, of kinetic and potential energies of a body moving with simple harmonic motion (02marks)

Variation of kinetic and potential energy in S.H.M

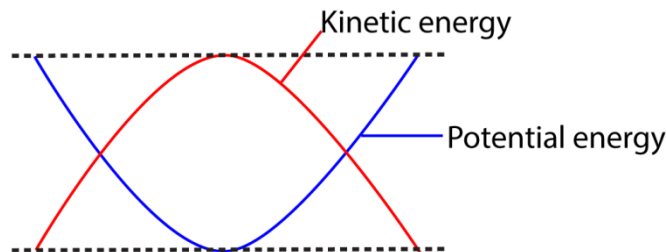

(c) A mass of 0.1kg suspended from a spring of force constant 24.5Nm^{-1} is pulled vertically downwards through a distance 5.0cm and released. Find the

(i) period of acceleration (02marks)

$$\text{From } T = 2\pi \sqrt{\frac{m}{k}}$$

$$T = 2\pi \sqrt{\frac{0.1}{24.5}} = 0.4 \text{s}$$

(ii) position of the mass 0.3s after release. (04marks)

From $x = A \sin(\omega t + \epsilon)$; where ϵ is the phase angle which is dependent on the position of the particle when the timing starts.

Given that $A = -5\text{cm} = -5 \times 10^{-2}\text{m}$ (displacement is negative because it is below the equilibrium position).

$$\therefore -5 \times 10^{-2} = 5 \times 10^{-2} \times \sin \epsilon$$

$$\epsilon = \frac{\pi}{2} \text{ radians}$$

At $t = 0.3\text{s}$

$$x = 5 \times 10^{-2} \sin(0.3\omega - \frac{\pi}{2})$$

$$\text{But } \omega = \frac{2\pi}{T} = \frac{2\pi}{0.4} = 15.7 \text{ rads}^{-1}$$

$$x = 5 \times 10^{-2} \sin(0.3 \times 15.7 - \frac{\pi}{2}) = 1.19 \times 10^{-4} \text{m}$$

69. (a) (i) what is meant by the dimensions of a physical quantity? (01mark)

Dimensions of a physical quantity is the way a physical quantity is related to the fundamental quantities of mass (M), length (L) and time (T)

(ii) For stream line flow of non-viscous, incompressible fluid, the pressure, P, at a point is related to height, h, and the velocity, V by the equation $(P-a) = \rho g(h-b) + \frac{1}{2} (\rho v^2 - d)$ where a, b, and d, are constants and ρ is the density of the fluid and g is the acceleration due to gravity. Given that the equation is dimensionally consistent, find the dimensions of a, b and d. (03marks)

$$[a] = [P] = \text{ML}^{-1}\text{T}^{-2}$$

$$[b] = [h] = \text{L}$$

$$[d] = [\rho v^2] = (\text{LT}^{-1})^2 = \text{L}^2\text{T}^{-2}$$

(b) Define simple harmonic motion. (01marks)

Simple harmonic motion is a periodic motion whose acceleration is directed towards a fixed point and is proportional to the displacement from the fixed point.

(c) Sketch the following graphs for a body performing simple harmonic motion:

(i) velocity against displacement (01mark)

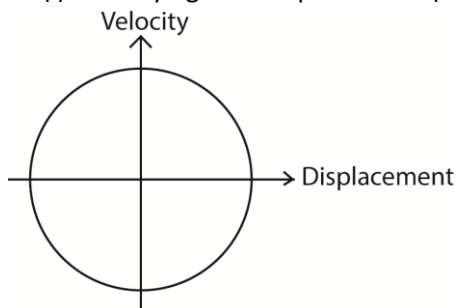

(ii) displacement against time (01mark)

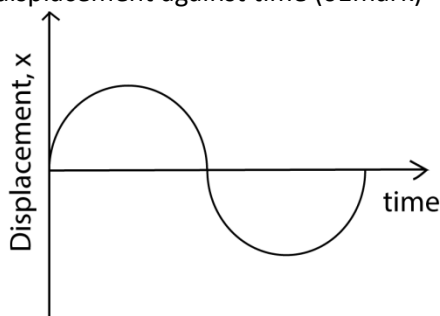

- (d) The period of oscillation of a conical pendulum is 2.0s. If the string makes 60° to the vertical at the point of suspension, calculate the
 (i) vertical height of the point of suspension above the circle. (03marks)

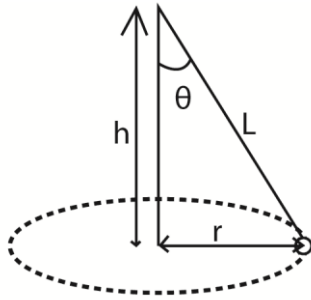

For conical pendulum, $T = 2\pi \sqrt{\frac{h}{g}}$
 $h = \frac{T^2 g}{4\pi^2} = \frac{2^2 \times 9.81}{4\pi^2} = 0.994\text{m}$

- (ii) length of the string (01 mark)

$h = L \cos \theta$
 $L = \frac{0.994}{\cos 60} = 1.1.99\text{m}$

- (iii) Velocity of the mass attached to the string (03marks)

$V = \omega r$; $r = L \sin \theta = 1.99 \sin 60 = 1.723\text{m}$

$\omega = \frac{2\pi}{T} = \pi \Rightarrow V = 1.723\pi \times = 5.41\text{ms}^{-1}$

- (e) (i) give one example of an oscillatory motion which approximates simple harmonic motion

- Simple pendulum
- Mass of helical spring
- Liquid oscillating in U-tube

- (ii) What approximation is made in (e)(i) above? (01mark)

- For simple pendulum, the angle of displacement is small and air friction is negligible
- Helical spring, displacement is small
- Oscillating liquid in U tube experience negligible friction and small displacement

- (f) Explain why the acceleration of a ball bearing falling through a liquid decreases continuously until it become zero. (04marks).

Viscous force increases with velocity until the Upthrust + viscous force = weight of the ball reducing acceleration to zero

70. (a) (i) State Newton's law of universal gravitation. (01mark)

The gravitational force of attraction between two bodies in the universe is proportional to the product of their masses and inversely proportional to the square of their distance apart.

- (iii) Show that this law is consistent with Kepler's third law. (03marks)

By Newton's law of gravitation, $F = \frac{GMm}{r^2}$

From uniform circular motion, $mr\omega^2 = \frac{GMm}{r^2}$; but $\omega = \frac{2\pi}{T}$

Thus $\frac{GMm}{r^2} = \left(\frac{mr \times 4\pi^2}{T^2}\right)$

$\Rightarrow T^2 = \left(\frac{4\pi^2}{GM}\right)r^3$

Thus $T^2 \propto r^3$ - Kepler's law.

(iii) Two alternative units for gravitational field strength are Nkg^{-1} and ms^{-2} . Use the method of dimensions to show that the two units are equivalent. (03marks)

Nkg^{-1} is the unit of $\frac{\text{Force}}{\text{mass}}$

$\frac{[\text{Force}]}{[\text{mass}]} = \frac{MLT^{-2}}{M} = LT^{-2}$

Also $[\text{ms}^{-2}] \equiv LT^{-2}$

Hence the two units are equivalent

(b) (i) Derive an expression for speed of a body moving uniformly in a circular path. (03marks)

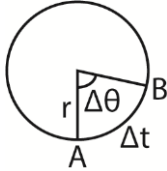

Let the body move from A to B in time Δt such that the radius sweeps through a small angle $\Delta\theta$

Average speed = $\frac{\text{distance}}{\text{time}} = \frac{r\Delta\theta}{\Delta t}$

For small values of $\Delta\theta$ and Δt , $\frac{d\theta}{dt} = \omega$

Hence average speed, $v = r\omega$

(ii) Explain why a force is necessary to maintain a body moving with constant speed in a circular path. (02marks)

To provide centripetal force

(c) A small mass attached to a string suspended from a fixed point moves in a circular path at constant speed in horizontal plane.

(i) Draw a diagram showing the force acting on the mass. (01mark)

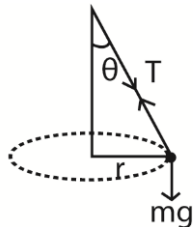

(ii) Derive an equation showing the angle of inclination of the string depends on the speed of the mass and radius of the circular path. (03marks)

Resolving horizontally, $T\sin\theta = \frac{mv^2}{r}$ (i)

Resolving vertically, $T\cos\theta = mg$ (ii)

Combining eqn. (i) and eqn (ii)

$\tan\theta = \frac{v^2}{rg}$

(d) (i) Define moment of force. (01mark)

Moment of force is the product of force and the perpendicular distance from axis of rotation to the line of action of force.

(ii) A wheel of radius 0.2m is pivoted at its centre. A tangential force of 4.0N acts on the wheel so that the wheel rotates with uniform velocity. Find the work done by the force to turn the wheel through 10 revolutions. (03marks)

$$\text{Work done} = F \times 2\pi r \times \text{number of revolutions} = 4 \times 0.5 \times 2\pi \times 10 = 151\text{J}$$

71. (a) (i) Show that the weight of a fluid displaced by an object is equal to up thrust on the object. (05marks)

Consider a vertical cylinder of cross section area, A, immersed in a liquid of density ρ as shown in the diagram below

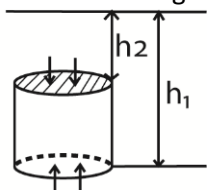

If H is the atmospheric pressure.

$$\text{Pressure on top} = h_2\rho g + H$$

$$\text{Pressure at the base} = h_1\rho g + H$$

$$\text{Force on the base} = (h_1\rho g + H)A$$

$$\text{Force on the top} = (h_2\rho g + H)A$$

$$\text{Resultant force} = (h_1 - h_2)\rho g A$$

But $(h_1 - h_2)A = \text{volume of the cylinder} = \text{volume of liquid displaced.}$

$$\therefore (h_1 - h_2)\rho g A = \text{weight of the liquid displaced} = \text{Upthrust.}$$

(ii) A piece of metal of mass $2.60 \times 10^{-3}\text{kg}$ and density $8.4 \times 10^3\text{kgm}^{-3}$ is attached to a block of wax of mass $1.0 \times 10^{-2}\text{kg}$ and density $9.2 \times 10^2\text{kgm}^{-3}$. When the system is placed in a liquid, it floats with wax just submerged. Find the density of the fluid. (04marks)

Let the density of the liquid = ρ

Upthrust = weight of the system

$$V\rho g = (2.6 \times 10^{-3} + 1 \times 10^{-2})g$$

$$\left(\frac{2.6 \times 10^{-3}}{8.4 \times 10^3} + \frac{1.0 \times 10^{-2}}{9.2 \times 10^2} \right) \rho = 1.26 \times 10^{-2}$$

$$\rho = 1.13 \times 10^3\text{kgm}^{-3}$$

(b) Explain the

(i) term laminar flow and turbulent flow. (04marks)

Laminar flow: Equidistant fluid layers from the axis of flow have the same velocity. Lines of flow are always parallel to the axis of flow

Turbulent flow: equidistant fluid layers from the axis of flow have different velocities. Lines of flow cross each other.

(ii) effects of temperature on viscosity of liquids and gases. (03marks)

- In liquids increasing temperature increases molecular speed and separation. This reduces the molecular attractive forces and viscosity reduces.

- In gases increase in temperature increases molecular speed and therefore momentum transfer when they collide increases. This increases viscosity.

(c) (i) distinguish between static pressure and dynamic pressure. (02marks)

- **Static pressure** at a point is the pressure which the fluid would have if were at rest.
- **Dynamic pressure** is the pressure due to fluid motion.

(ii) A pilot-static tube fitted with a pressure gauge is used to measure the speed of a boat at sea. Given that the speed of the boat does not exceed 10mms^{-1} and the density of water is 1000kgm^{-3} , calculate the minimum pressure on the gauge. (02marks)

$$\text{Maximum pressure} = \frac{1}{2}\rho v^2 = \frac{1}{2} \times 1050 \times 10^2 = 5.25 \times 10^4\text{Pa}$$

72. (a) Define the terms surface tension and surface energy. (01mark)

It is the work done per unit area in increasing surface area of a liquid under isothermal conditions.

(b) (i) Calculate the work done against surface tension in blowing a soap bubble of diameter 15mm, if the surface tension of soap solution is $3.0 \times 10^{-2}\text{Nm}$. (03marks)

$$\text{New surface area created} = 2 \times 4\pi r^2$$

$$\begin{aligned} \text{Energy required} &= \gamma A = 3.0 \times 10^{-2} \times 2 \times 4\pi \times (7.5 \times 10^{-3})^2 \\ &= 4.24 \times 10^{-5}\text{J} \end{aligned}$$

(ii) A soap bubble of radius r_1 is attached to another bubble of radius r_2 . If r_1 is less than r_2 . Show that the radius of curvature of the common interface is $\frac{r_1 r_2}{r_2 - r_1}$. (05marks)

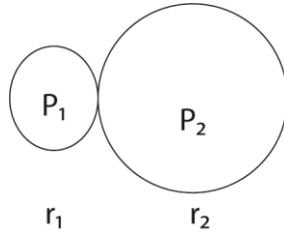

For A

$$P_1 - H = \frac{4\gamma}{r_1} \dots\dots\dots (i)$$

For B

$$P_2 - H = \frac{4\gamma}{r_2} \dots\dots\dots (ii)$$

From equations (i) and (ii)

$$P_1 - P_2 = \frac{4\gamma}{r_1} - \frac{4\gamma}{r_2} \dots\dots\dots (iii)$$

$$P_1 - P_2 = \frac{4\gamma}{r} \dots\dots\dots (iv)$$

From equation (iii) and (iv)

$$\frac{4\gamma}{r} = \frac{4\gamma}{r_1} - \frac{4\gamma}{r_2}$$

$$\frac{1}{r} = \frac{1}{r_1} - \frac{1}{r_2}$$

$$\frac{1}{r} = \frac{r_2 - r_1}{r_2 r_1}$$

$$r = \frac{r_2 r_1}{r_2 - r_1}$$

- (c) (i) Define coefficient of viscosity of a liquid. (01mark)
It is the tangential stress per unit velocity gradient.
- (ii) Describe an experiment to demonstrate streamline and turbulent flow in liquids. (06marks)

Experiment to demonstrate laminar and turbulent flow

Reynold's experiment

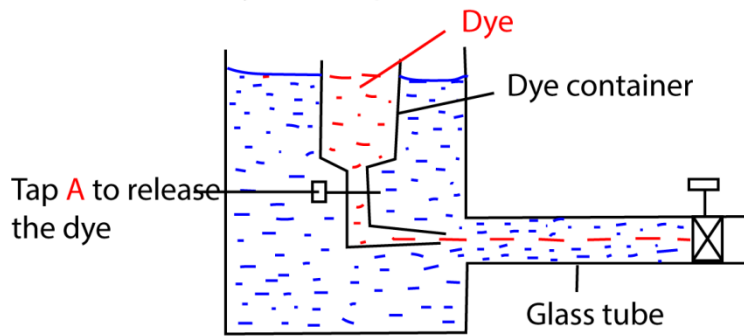

- Water is kept flowing at a constant velocity from a constant water tank.
- The rate of flow of a dye is controlled by a tap A.
- At low water velocity a streamline of a dye is observed flowing through water. This is laminar flow
- A turbulent flow is observed when the velocity of water is increased here the dye mixes with water.

- (d) (i) Sketch a graph of potential energy against separation of two molecules of a substance. (01mark)

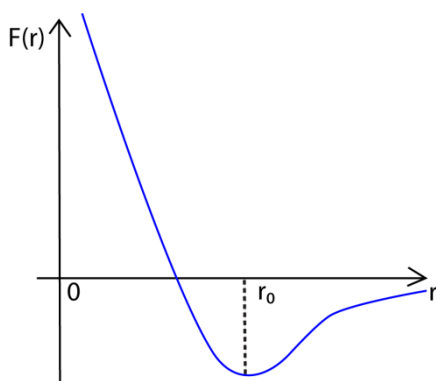

- (ii) Explain the main features of the graph in (d)(i). (03marks)

At $r = r_0$, the resultant force is zero and the corresponding potential energy is minimum. So r_0 is the equilibrium separation

For $r < r_0$, the net force is repulsive, whereas $r > r_0$, the net force is attractive in order to

restore the e separation to the equilibrium separation of r_0 .

73. (a) (i) State the principle of conservation of mechanical energy. (01mark)

The total mechanical energy (K.E + P.E) of a body in an isolated system is constant.

(ii) Show that a stone thrown vertically upwards obeys the principle in (a)(i) above throughout its upward motion. (04marks)

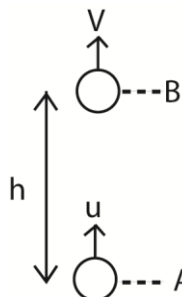

At A, K.E = $\frac{1}{2}mu^2$, P.E = 0

Total energy at A = K.E + P.E = $\frac{1}{2}mu^2 + 0 = \frac{1}{2}mu^2$

At B, K.E = $\frac{1}{2}mv^2$; P.E = mgh

Total energy at B, = $\frac{1}{2}mv^2 + mgh$

But $v^2 = u^2 - 2gh$

Total energy at B = $\frac{1}{2}m(u^2 - 2gh) + mgh = \frac{1}{2}mu^2$

∴ Total energy at A = total energy at B

(b)(i) A wind turbine made of a blade of radius, r , is driven by wind of speed, V . If σ is the density of air, derive an expression for minimum power, P , which can be developed by the turbine in terms of σ , r and V . (03marks)

$$\text{K.E} = \frac{1}{2}mv^2$$

Volume of air striking blade per second = πr^2v

Mass of air striking the blade per second = $\pi r^2v^3\sigma$

∴ Power available = K.E of air per second

$$= \frac{1}{2}\pi r^2v^3\sigma$$

(ii) Explain why the power attained is less than the maximum value in (b)(i) above. (02marks)

- Velocity of air is not reduced to zero as assumed in the calculation which means that not all the K.E of the air per second is passed on to the blade
- Some power is wasted as heat due to friction forces in the parts

(c) State the conditions under which the following will be conserved in collision between two bodies

(i) linear momentum (10mark)

- no external force on interacting bodies

(ii) kinetic energy (01mark)

- The interaction must be perfectly elastic or must move separately after collision

(d) Two pendulum bobs A and B of equal length L , and masses $3M$ and M respectively. The pendula are hung with bobs in contact as shown below

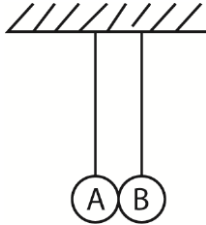

The bob A is displaced such that the string makes an angle θ with the vertical and released. If A makes a perfectly inelastic collision with B, find the height to which B rises. (08marks)

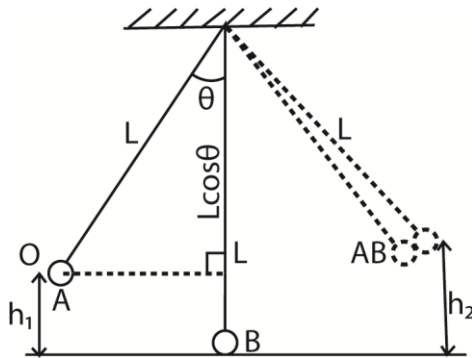

Let h_1 be the height of A above the ground when the string is inclined at an angle θ to the vertical

$$h_1 = L - L \cos \theta$$

K.E of A before collision = Initial P.E of A at O

$$\text{Initial P.E at O} = 3Mgh_1 = 3MgL(1 - \cos \theta) \dots\dots\dots (i)$$

If u_1 is the velocity of A before collision

$$\frac{1}{2}(3M)u_1^2 = 3MgL(1 - \cos \theta)$$

$$u_1 = \sqrt{2gL(1 - \cos \theta)}$$

Momentum is conserved after collision, if v is the velocity after collision

$$3M\sqrt{2gL(1 - \cos \theta)} = (3M + M)v$$

$$v = \frac{3}{4}\sqrt{2gL(1 - \cos \theta)}$$

From conservation of energy, kinetic energy before collision = maximum potential energy gained.

$$\frac{1}{2} \times (3M + M) \left(\frac{3}{4}\sqrt{2gL(1 - \cos \theta)} \right)^2 = (3M + M)gh_2$$

$$\frac{1}{2} \times \frac{9}{16} (2gL(1 - \cos\theta)) = gh_2$$

$$h_2 = \frac{9}{16} gL(1 - \cos\theta)$$

74. (a) Define the following terms

(i) Stress (01mark)

Stress is the force acting per unit cross sectional area

Strain is the extension per unit original length.

(ii) Strain (01mark)

(b) The velocity, V , of sound travelling along a rod made of a material of Young's Modulus,

Y , and density, ρ is given by $V = \sqrt{\frac{Y}{\rho}}$.

Show that the formula is dimensionally consistent. (03marks)

$$[V] = LT^{-1}$$

$$[Y] = \frac{[F][L]}{[A][e]} = \frac{MLT^{-2}L}{L^2.L} = MLT^{-2}$$

$$[\rho] = ML^{-3}$$

$$[V] = \sqrt{\frac{[Y]}{[\rho]}} = \sqrt{\frac{MLT^{-2}}{ML^{-2}}} = LT^{-1}$$

Hence the formula is dimensionally consistent.

(c) State the measurement necessary in the determination of Young's Modulus of a metal wire. (02marks)

- Original length of the sample wire
- Diameter, d , of the wire to find $A = \frac{\pi d^2}{4}$
- Extension, e , of the wire
- load

(d) Explain why the following precautions are taken during an experiment to determine Young's Modulus of a metal wire.

(i) two long, thin wires of the same material are suspended from a common support. (02marks)

Long and thin to enable measurable extension

Same material and suspended from common support to cater for thermal expansion and other factors

(ii) the readings of the vernier are also taken when the loads are gradually removed in steps. (01marks)

To ensure that elastic limit is not exceeded, and to obtain average values for extensions.

(e) The ends of a uniform wire of length 2.00m are fixed to points A and B which are 2.00m apart in the same horizontal line. When a 5kg mass is attached to the mid-point C of the wire, the equilibrium position of C is 7.5cm below the line AB. Given that Young's Modulus for the material of the wire is $2.0 \times 10^{11} \text{Pa}$, find

(i) the strain in the wire (03marks)

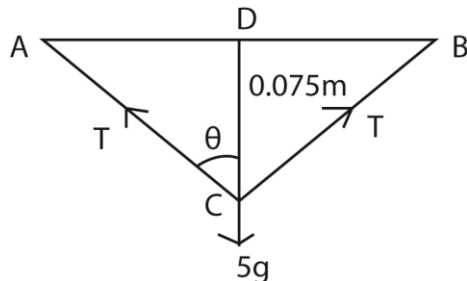

$$AC = CB = \sqrt{(0.075)^2 + 1^2} = 1.003\text{m}$$

$$ACB = 2 \times 1.003 = 2.006\text{m}$$

$$\text{Extension} = 2.006 - 2.000 = 0.006\text{m}$$

$$\text{Strain} = \frac{e}{L} = \frac{0.006}{2} = 3 \times 10^{-3}$$

(ii) the stress in the wire, (02marks)

$$\text{From } E = \frac{\text{Stress}}{\text{Strain}}$$

$$\text{Stress} = 2 \times 10^{11} \times 3 \times 10^{-3} = 6 \times 10^8 \text{Nm}^{-2}$$

(iii) The energy stored in the wire (04marks)

Resolving vertically;

$$T \cos \theta + T \cos \theta = mg$$

$$2T \cos \theta = mg \text{ but } \theta = \tan^{-1} \left(\frac{1}{0.075} \right) = 85.7^\circ$$

$$\therefore T = \frac{Mg}{2 \cos \theta} = \frac{5 \times 9.81}{2 \cos 85.7^\circ} = 327.1\text{N}$$

$$\text{Energy stored} = \frac{1}{2} T e = \frac{1}{2} \times 327.1 \times 6 \times 10^{-3} = 0.9813\text{J}$$

(iv) State any assumptions made. (01mark)

Elastic limit is not exceeded.

75. (a) Define surface tension and derive its dimensions (03marks)

Surface tension is the force per unit length acting perpendicularly to one side of an imaginary line.

$$\gamma = \frac{\text{Force}}{\text{length}} = \frac{[Ma]}{[L]} = \frac{MLT^{-2}}{L} = MT^{-2}$$

(b) Explain using the molecular theory the occurrence of surface tension. (04 marks)

Molecules at the liquid surface have greater molecular separation than the equilibrium separation. These molecules experience greater attraction from their neighbours. This puts

them in a state of tension. Thus the liquid surface behaves like a stretched elastic skin, a phenomenon called surface tension

(c) Derive an experiment to measure surface tension of a liquid by the capillary tube method. (06marks)

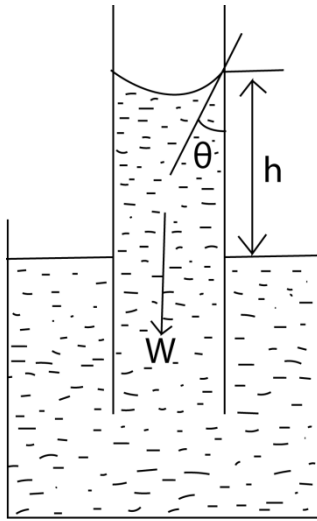

A capillary tube of radius, r , is vertically placed in a liquid. The liquid rises until the vertical component of the upward forces due to surface tension is equal to the weight of the liquid column.

$$F\gamma\cos\theta = W$$

$$\gamma = \frac{F}{L}$$

$$F = \gamma L$$

$$L = 2\pi r$$

But $W = mg$ and $m = V\rho$ (where ρ is the density of the liquid in kg/m^3)

$$W = v\rho g = 2\pi r^2 h\rho g$$

$$F\gamma\cos\theta = 2\pi r^2 h\rho g$$

$$\gamma \cdot 2\pi r \cos\theta = 2\pi r^2 h\rho g$$

$$\gamma = \frac{hr\rho g}{2\cos\theta}$$

γ – coefficient of surface tension

θ – angle of contact

ρ – density of the liquid

(d) (i) Show that the excess pressure in a soap bubble is given by $P = \frac{4\gamma}{r}$, (03marks)

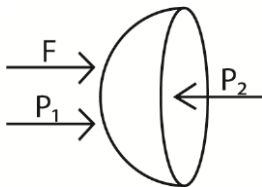

A soap bubble has two liquid surfaces in contact with air, one inside the bubble and the other outside the bubble.

The force, F , on one half of the bubble due to surfaces is thus $= \gamma \times 2\pi r \times 2 = 4\pi r\gamma$

For equilibrium of A, it follows that.

$$4\pi r\gamma + \pi r^2 \times P_1 = \pi r^2 \times P_2$$

Where P_2 , and P_1 are pressure inside and outside the bubble respectively

Simplifying

$$P_2 - P_1 = \frac{4\gamma}{r}$$

Therefore, excess pressure, $P = \frac{4\gamma}{r}$

- (ii) Calculate the total pressure within a bubble of air of radius 0.1mm in water if the bubble is formed 10cm below the water surface and surface tension of water is $7.27 \times 10^{-2} \text{Nm}^{-1}$. [Atmospheric pressure = $1.01 \times 10^5 \text{Pa}$] (05marks)

$$\text{Excess pressure} = \frac{2\gamma}{r} = \frac{2 \times 7.27 \times 10^{-3}}{0.1 \times 10^{-2}} = 1454 \text{Pa}$$

$$\begin{aligned} \text{Total pressure within the bubble} &= \text{atmospheric pressure} + h\rho g + \text{excess pressure} \\ &= 1.01 \times 10^5 + (0.1 \times 10^3 \times 9.81) + 1454 \\ &= 1.034 \times 10^5 \text{Pa} \end{aligned}$$

76. (a) (i) Define coefficient of viscosity and determine its dimensions. (04marks)

Coefficient of viscosity is the fractional force acting on an area of 1m^2 of a fluid when it is in a region of unit velocity gradient.

$$\eta = \frac{\text{Force}}{\text{velocity gradient}} = \frac{F}{A(V_2 - V_1)/L}$$

$$[\eta] = \frac{[F]}{[A][(V_2 - V_1)/L]} = \frac{MLT^{-2}}{L^2 \times \left(\frac{LT^{-1}}{L}\right)} = ML^{-1}T^{-1}$$

- (ii) The resistive force on a steel ball bearing of radius, r , falling with speed, V , in a liquid of viscosity, η is given by $F = K\eta rV$, where K is a constant. Show that K is dimensionless. (04marks)

$$K = \frac{F}{\eta rV}$$

$$[K] = \frac{[F]}{[\eta][r][V]} = \frac{MLT^{-2}}{(ML^{-1}T^{-1})(L)(LT^{-1})} = 1$$

$\therefore K$ is dimensionless

- (b) Write down Bernoulli's equation for fluid flow, defining all symbols used (03marks)

$P + \frac{1}{2}\rho v^2 + h\rho g = \text{constant}$, where P = pressure, ρ = density of fluid, v = velocity of fluid, h = height above a reference level and g = acceleration due to gravity.

- (c) A venturi meter consists of a horizontal tube with a constriction which replaces part of the piping system as shown below

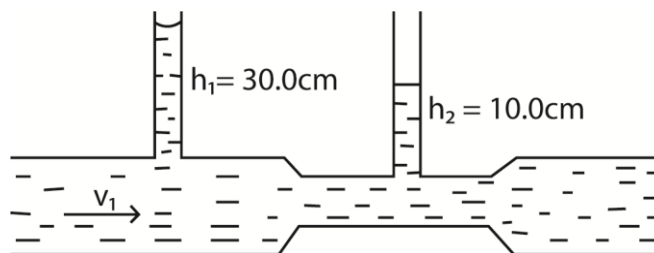

If the cross-sectional area of the main pipe is $5.81 \times 10^{-3} \text{m}^2$ and that of the constriction is $2.58 \times 10^{-3} \text{m}^2$, find the velocity v_1 of the liquid in the main pipe. (5marks)

From $P + \frac{1}{2}\rho v^2 + h\rho g = \text{constant}$

$$P_1 + \frac{1}{2}\rho v_1^2 + h_1\rho g = P_2 + \frac{1}{2}\rho v_2^2 + h_2\rho g \text{ but } P_1 = P_2$$

$$g(h_1 - h_2) = \frac{1}{2}(v_2^2 - v_1^2)$$

Also $A_1v_1 = A_2v_2$ from continuity equation

$$\frac{v_1}{v_2} = \frac{A_1}{A_2} \Rightarrow v_2 = \frac{A_1v_1}{A_2}$$

$$\therefore g(h_1 - h_2) = \frac{1}{2}\left(\left(\frac{A_1}{A_2}\right)^2 - 1\right)v_1^2$$

$$0.2 \times 9.81 = \frac{1}{2}\left[\left(\frac{5.81}{2.58}\right)^2 - 1\right]v_1^2; v_1 = 0.98\text{ms}^{-1}$$

(d) Explain the origin of the lift on an aeroplane at take-off. (04marks)

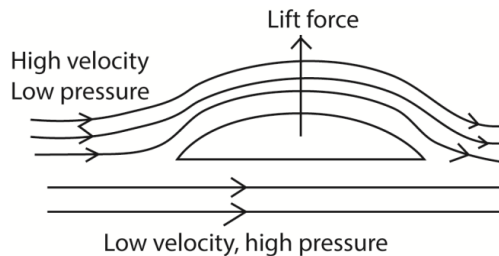

- Air flows above the wing of a plane at high velocity hence low pressure.
- Below the wings, air flows at low velocity and hence high pressure.
- The difference in pressure cause a lift force, therefore net upward force.

77. (a) (i) State Newton's laws of motion (03marks)

- A body continues in its state of rest or uniform motion in a straight line unless acted upon by an external force
- The rate of change of momentum of a body is directly proportional to applied force and takes place in the direction of the force
- For every action, there is an equal and opposite reaction

(ii) Define impulse and derive its relation to linear momentum of the body on which it acts. (03marks)

Impulse is the product of force and the time for which it acts.

$$F = ma$$

$$F = m\left(\frac{v-u}{t}\right)$$

$$Ft = mv - mu$$

Hence impulse = change in momentum

(b) A body of mass m_1 and velocity, u_1 collides head on with a body of mass, m_2 having velocity, u_2 in the same direction as u_1 . Use Newton's laws to show that the quantity $m_1u_1 + m_2u_2$ is conserved. (5marks)

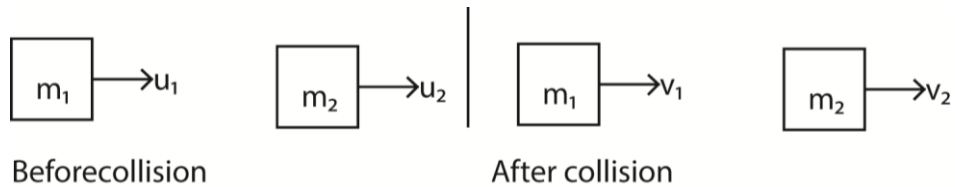

During collision, each body exerts a force of impact on each other according to Newton's second law of motion.

Let I be the impulse on A, then the impulse on B = $-I$.

$$I = M_1v_1 - m_1u_1 \dots\dots\dots (i)$$

$$-I = m_2v_2 - m_2u_2 \dots\dots\dots (ii)$$

Equation (i) + equation (ii)

$$0 = M_1v_1 - m_1u_1 + m_2v_2 - m_2u_2$$

$$m_1u_1 + m_2u_2 = m_1v_1 + m_2v_2$$

- (c) A ball of mass 0.5kg is allowed to drop from rest, from a point a distance of 5.0m above a horizontal concrete floor. When the ball first hits the floor, it rebounds to a height of 3.0m.

- (i) What is the speed of the ball just after the first collision with the floor? (3marks)

From $v^2 = u^2 + 2as$

$$v^2 = 0 + 2 \times 9.81 \times 5$$

$$v = 9.9\text{ms}^{-1}$$

After collision, using $v^2 = u^2 + 2as$

$$0 = u^2 - 2 \times 9.81 \times 3$$

$$u = 7.672\text{ms}^{-1}$$

- (ii) If the collision lasted 0.01s, find the average force which the floor exerts on the ball. (02marks)

(02marks)

Impulse = change in momentum.

$$F = m \left(\frac{v-u}{t} \right) = \frac{0.5(7.672-9.9)}{0.01} = 878.9\text{N}$$

78. (a) (i) state Archimedes' Principle. (01mark)

Archimedes' Principle states that when a body is wholly or partially immersed in a fluid, it experiences an upthrust equal to the weight of fluid displaced.

- (ii) What is simple harmonic motion? (02marks)

Simple harmonic motion is a periodic motion of a body in which the acceleration due to of the body is directly proportional to the displacement from a fixed point and directed to that fixed point.

- (b) A uniform cylindrical rod of length 0.08m, cross sectional area 0.02m² and density 900kgm⁻³ floats vertically in a liquid of density 1000kgm⁻³. The rod is displaced through a distance of 0.005m and released.

- (i) Show that the rod performs simple harmonic motion. (05marks)

Consider a cylinder of mass, m , floating vertically in a liquid of density, ρ , to a depth, h

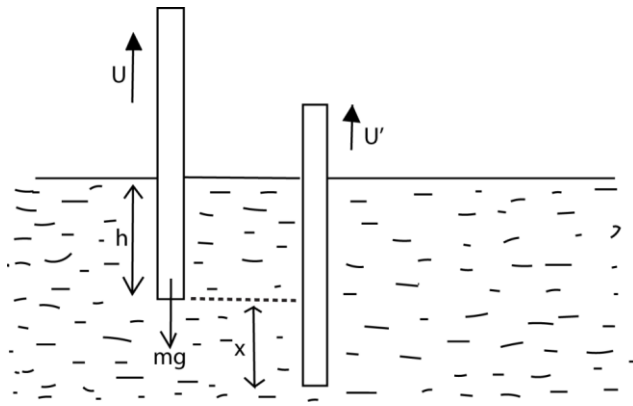

At equilibrium position, the body sinks to a height, h , below the liquid surface

Up thrust = weight of the body

But $U = Ah\rho g$

$$mg = Ah\rho g \dots\dots\dots(i)$$

A is the cross section area of a cylinder

When a body is displaced through a distance, x , and released,

$$\text{Up thrust} = (h + x) A\rho g$$

$$\text{Resultant force} = mg - (h + x) A\rho g$$

But, $m = Ah\rho$

$$AL\rho a = Ah\rho g - Ah\rho g - A\rho gx$$

$$a = \frac{-A\rho gx}{Ah\rho} = \frac{-gx}{h}$$

But $a = -\omega^2 x$

Hence it performs simple harmonic motion with $\omega^2 = \frac{g}{h}$

(ii) Find the frequency of the resultant oscillation. (04marks)

From $\omega = 2\pi f$

$$4\pi^2 f^2 = \frac{g}{h}$$

$$f = \frac{1}{2\pi} \sqrt{\frac{g}{h}} = \frac{1}{2\pi} \sqrt{\frac{9.81}{0.08}} = 1.76$$

(iii) Find the velocity of the rod when it is a distance of 0.004m above the equilibrium position. (03marks)

$$v = \omega \sqrt{a^2 - x^2} = 2\pi f \sqrt{a^2 - x^2} = 2\pi \times 1.76 \sqrt{0.005^2 - 0.003^2} = 0.04 \text{ms}^{-1}$$

(c)

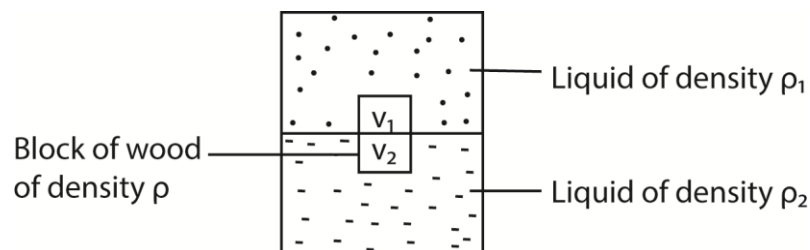

A block of wood of density ρ floats at the interface between immiscible liquids of densities ρ_1 and ρ_2 as shown in the figure above.

(i) Show that the ratio of volumes v_1 to v_2 of the block in the two liquids is given by

$$\frac{v_1}{v_2} = \frac{\rho_2 - \rho}{\rho - \rho_1} \text{ (04marks)}$$

Total upthrust = weight of a liquid displaced
= weight of floating solid

$$\Rightarrow V_1\rho_1g + V_2\rho_2g = (V_1 + V_2)\rho g$$

$$V_1(\rho_1 - \rho) = V_2(\rho - \rho_2)$$

$$\frac{V_1}{V_2} = \frac{\rho - \rho_2}{\rho_1 - \rho}$$

- (ii) What happens when this block of wood is replaced with a denser one? (01mark)
The block sinks deeper

79. (a) Distinguish between scalar and vector quantities. Give two examples each. (03marks)
A scalar quantity has magnitude but no direction, e.g. volume, Mass, speed, density, temperature

A vector quantity has magnitude and direction, e.g. acceleration, velocity, and displacement, momentum, impulse

- (b) (i) Define the time of flight and range as applied to projectile motion. (02 marks)

Time of flight is the time taken by a projectile to move from the point of projection to where it lands

- (ii) A projectile is fired in air with a speed $u \text{ ms}^{-1}$ at an angle θ to the horizontal. Find the time of flight of the projectile (02marks)

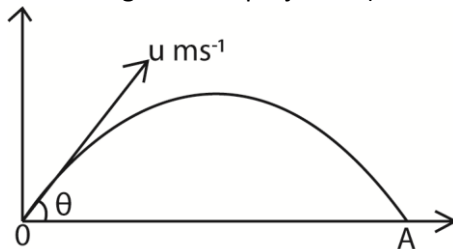

At point A, the vertical distance covered above the point of projection is zero

$$\text{From } s = ut + \frac{1}{2}at^2$$

$$0 = u \sin \theta \times t - \frac{1}{2}gt^2$$

$$t = \frac{2u \sin \theta}{g}$$

therefore the time of flight of projectile is $\frac{2u \sin \theta}{g}$.

- (c) State the conditions for equilibrium of a rigid body under action of coplanar forces. (02marks)

- The algebraic sum of all the forces acting in one direction is equal to the algebraic sum of all the forces acting in the opposite direction.

Or

- The algebraic sum of all moments of forces at any given point is equal to zero.

- (d) A mass of 5.0kg is suspended from the end A of a uniform beam of mass 1kg and length 1.0m. The end B of the beam is hinged in a wall. The beam is kept horizontal by a rope attached to A and a point C, in the wall at a height 0.75m above B.

- (i) Draw a sketch diagram to show the forces acting on the beam. (02marks)

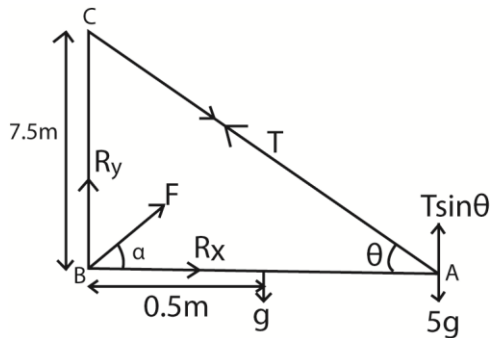

(ii) Calculate the tension in the rope. (04marks)

$$\text{Moments At B: } T \times 1 \sin \theta = 1.0 \times 0.5 + 5g \times 1$$

$$\text{But } \tan \theta = 36.9^\circ$$

$$T = \frac{5.5 \times 9.8}{\sin 36.9} = 89.9 \text{ N}$$

(iii) What is the force exerted by the hinge on the beam? (05marks)

$$R_x = 0.8T = 0.8 \times 89.9 = 71.9 \text{ N}$$

$$R_y = 6 \times 9.81 - 0.6 \times 89.9 = 4.9 \text{ N}$$

$$\text{Resultant, } R = \sqrt{R_x^2 + R_y^2} = \sqrt{71.9^2 + 4.9^2} = 72.1 \text{ N}$$

$$\text{Direction: } \tan \alpha = \frac{R_y}{R_x} = \frac{4.9}{71.9}; \alpha = 3.89^\circ$$

80. (a) State Kepler's laws of gravitation (03marks)

- Planets describe ellipses about the sun as one focus
- The imaginary line joining the sun and planet sweeps out equal areas in equal time intervals
- The square of the periodic time of revolution of planets about the sun are proportional to the cubes of their mean distance from the sun

(b) (i) Show that the period of a satellite in a circular orbit of radius r about the earth is

given by $T = \left(\frac{4\pi^2}{GM_s} \right)^{\frac{1}{2}} r^{\frac{3}{2}}$ where G is the universal constant and M_s is the mass of the earth. (05marks)

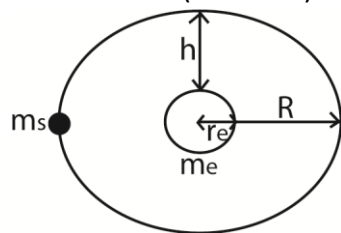

Centripetal force required to maintain circular motion is provided by the gravitational force of attraction between the earth and satellite.

From Newton's of gravitation

$$F = \frac{Gm_s m_e}{R^2}$$

$$\therefore m_s \omega^2 R = \frac{Gm_s m_e}{R^2}$$

$$\omega^2 = \frac{Gm_e}{R^3} \text{ but } \omega = \frac{2\pi}{T}$$

$$\Rightarrow \left(\frac{2\pi}{T}\right)^2 = \frac{Gm_e}{R^3}$$

$$T = \left(\frac{4\pi^2}{GM_s}\right)^{\frac{1}{2}} r^{\frac{3}{2}}$$

- (ii) Explain briefly how world-wide radio or television communication can be achieved with the help of satellites. (04marks)

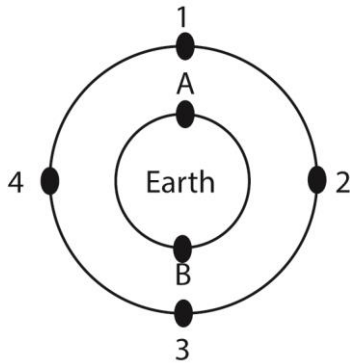

- A set of satellites is launched in parking orbit as shown in the diagram above.
- A radio signal from A is transmitted to a geosynchronous satellite 1
- The signals are retransmitted from satellite 1 to geosynchronous satellite 2, then to 3 and finally to B.

- (c) A satellite of mass 100kg is in a circular orbit at height of 3.39×10^7 m above the earth's surface.

- (i) Find the mechanical energy of the satellite (04marks)

$$\text{Mechanical energy, M.E.} = \frac{-Gm_em}{2r}; r = (3.59 \times 10^7 + 6.4 \times 10^6) = 4.23 \times 10^7 \text{m}$$

$$\text{M.E} = \frac{-6.67 \times 10^{-11} \times 5.97 \times 10^{24} \times 100}{2 \times 4.23 \times 10^7} = -4.71 \times 10^8 \text{J}$$

- (ii) Explain what would happen if the mechanical energy was decreased. (04marks)

From $\text{M.E.} = \frac{-Gm_em}{2r}$, when mechanical energy decreases, r , also decreases.

Therefore the satellite drops into an orbit of smaller radius. If mechanical energy continued to decrease, the satellite would enter the earth's atmosphere and would eventually burn out due to frictional resistance. Velocity and kinetic energy increase.