



Dr. Bbosa Science

This document is sponsored by
The Science Foundation College Kiwanga- Namanve
Uganda East Africa
Senior one to senior six
+256 778 633 682, 753 802709
Based on, best for sciences



Nurture your dreams

1. (a) What is meant by the following:
- Super-heated water? (01 mark)
Superheated water is **liquid water under pressure at temperatures between the usual boiling point, 100 °C and the critical temperature, 374 °C.**
 - Super cooled vapour? (01 mark)

(b) Explain how:

- a gas in a vessel exerts pressure. (03marks)

A gas in a vessel exerts pressure due to the constant motion and collisions of its molecules with the walls of the container. Each molecule that collides with of vessel exerts a small force on the wall; and the cumulative effect of numerous collisions over a given area generates a continuous force on the wall of the vessel. This force per unit area constitutes pressure of a gas.

- the atmosphere surrounding the earth prevents it from becoming unbearably cold. (03marks)

- atmosphere contain greenhouse gases and clouds that trap heat from the sun keeping the earth warm
- atmospheric gases act as insulators reducing temperature fluctuations
- circulation of atmospheric gases redistributes heat from the equator to cold paces

(c) A container of volume 0.2m^3 contains hydrogen gas of molar mass $2\text{g}\text{mol}^{-1}$ at a pressure of 1.5×10^4 Pa and a temperature of 27°C .

Calculate the:

- number of hydrogen molecules in the container. (03 marks)

$$\text{From } PV = nRT$$

$$1.5 \times 10^4 \times 0.2 = n \times 8.31 \times (273 + 17)$$

The number of moles of hydrogen gas, $n = \frac{1.5 \times 10^4 \times 0.2}{8.31 \times 290} = 1.2449$

Number of hydrogen molecules = $1.2449 \times 6.02 \times 10^{23}$
 $= 7.4943 \times 10^{23}$ molecules

(ii) mean square speed of the molecules. (03 marks)

$$P = \frac{1}{3} \rho c^2$$

Mass of hydrogen = $1.2449 \times 2 = 2.4898\text{g}$

$$\rho = \frac{M}{V} = \frac{2.4898}{0.2} = 12.449 \text{kgm}^{-3}$$

$$\sqrt{c^2} = \sqrt{\frac{3P}{\rho}} = \sqrt{\frac{3 \times 1.5 \times 10^4}{12.449}} = 60 \text{ms}^{-1}$$

(iii) root mean square speed of oxygen molecules at the same temperature. (Molar mass of oxygen – 32mol^{-1}) (02 marks)

$$\frac{c_{\text{O}}^2}{c_{\text{H}}^2} = \frac{m_{\text{H}}}{m_{\text{O}}}$$

Hence root mean square speed of oxygen = $\frac{2}{32} \times 60 = 3.75\text{ms}^{-1}$

(d) Sketch a graph of saturated vapour pressure of a liquid against temperature and explain the shape of the curve. (04 marks)

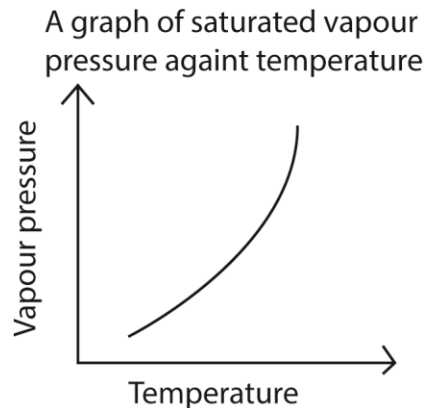

Saturated vapour pressure increases with temperature due to the increase in kinetic energy and the probability of molecules overcoming the intermolecular forces holding them in the liquid phase, allowing them to escape into the vapour phase

2. (a) Define the following as applied to heat: (03 marks)

(i) Conduction

Conduction is the transfer of heat from a region of high temperature to that of low temperature without a resultant movement of the molecules of conducting material.

(ii) Convection

Convection is a process of heat transfer in fluids from a region of high temperature to a region of low temperature, due to movement of the medium.

(iii) Radiation

Radiation is a means of heat transfer through a vacuum or that does not involve a medium

(b) (i) Define thermal conductivity and state its units. (02 marks)

Thermal conductivity is the rate of heat flow per unit cross section area per unit temperature gradient

Units: $\text{Wm}^{-1}\text{K}^{-1}$

(ii) Explain why the experiment to determine the thermal conductivity of a metal, the specimen is made thin and long. (02 marks)

- **Gradient Establishment:** A thin and long specimen ensures a well-defined temperature gradient along its length. This is crucial because thermal conductivity is measured based on the heat flow along the temperature gradient.
- **Reduced Heat Loss:** A thinner specimen minimizes lateral (side) heat loss, ensuring that most of the heat flows along the length of the specimen. This reduces errors and improves the accuracy of the experiment.

(c) The sun radiates as a black body at 6000K and it is $1.5 \times 10^{11}\text{m}$ from the earth. Given that radius of the sun is $7 \times 10^8\text{m}$, find the;

(i) solar flux on the earth's surface. (03marks)

$$\text{Solar flux} = \frac{4\pi r_s^2 \sigma T_s^4}{4\pi R^2} = \frac{4\pi (7 \times 10^8)^2 \times 5.67 \times 10^{-8} \times 6000^4}{4\pi (1.5 \times 10^{11})^2} = 1.6 \times 10^3 \text{Wm}^{-2}.$$

(ii) time it will take 2.5kg of ice at its melting point to melt when placed at the focal point of a concave mirror of diameter 0.8m whose axis is parallel to the sun's radiation. (03marks)

(Specific latent heat of fusion of ice is $3.36 \times 10^5 \text{Jkg}^{-1}$)

$$\text{Area of the mirror} = \pi r^2 = \pi (0.4)^2 = 0.5\text{m}^2$$

$$\text{Power reflected by the mirror per second} = 0.5 \times 1600 = 800\text{W}$$

Heat reflected = heat gained by ice

$$800t = 2.5 \times 3.36 \times 10^5$$

$t = 1,050s$ or 17.5minutes

(d) (i) Explain how a bolometer strip is used to detect radiation. (04marks)

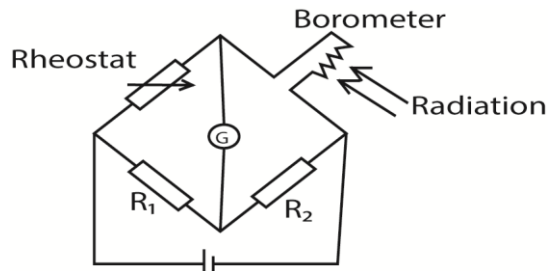

The bolometer strip is connected to Wheatstone bridge circuit above. The rheostat is adjusted until the galvanometer shows no deflection. When the radiations fall on the strip, they are absorbed and its temperature rises leading to an increase in resistance. The galvanometer deflects showing the presence of radiations.

(ii) Explain why the intensity of solar radiation on top of earth's atmosphere is higher than that on the earth's surface. (03 marks)

- Portion of the radiation is absorbed by clouds, ozone layer and other atmospheric particle before reaching earth's surface
- Portion of the radiation is reflected by clouds, ozone layer and other atmospheric particle before reaching earth's surface
- Portion of the radiation is scatter atmospheric particle before reaching earth's surface

3. (a) (i) What is meant by **isothermal** and **adiabatic** processes in a gas. (03marks)

Isothermal expansion takes place at constant temperature.

Adiabatic expansion takes place at constant heat.

(ii) State the conditions necessary to achieve the processes in (a)(i) (04 marks)

Isothermal process occurs at constant temperature and therefore the gas must be enclosed in thin walled container of good thermal conductivity placed in a large hot reservoir and occurs slowly enough to allow heat exchange with the surrounding.

Adiabatic process requires no heat input or out and therefore should occur rapidly in well insulated container like a thermos flask and gas should be ideal.

(iii) Explain why air coming out of a valve of a ball feels cold. (02marks)

This is due rapid (adiabatic) expansion accompanied with a decrease in temperature which cause a cold sensation.

- (b) A mass of air initially occupying a volume of 2000cm^3 at a pressure of 76mmHG and a temperature of 20°C expands adiabatically and reversibly to twice its volume. It is then compressed isothermally and reversibly to a volume of 3000cm^3 .

(i) Find the final temperature and pressure of the gas. (06marks)

Under adiabatic expansion

Initial temperature = $273 + 20 = 293$

Final temperature under adiabatic condition

$$T_1 V_1^{\gamma-1} = T_2 V_2^{\gamma-1}$$

$$\Rightarrow 293(2000)^{1.4-1} = T(4000)^{1.4-1}$$

$$T = \frac{293}{2^{0.4}} = 222.1\text{K}$$

Final pressures under adiabatic condition

$$P_1 V_1^\gamma = P_2 V_2^\gamma$$

$$76 \times (2000)^{1.4} = P(4000)^{1.4}$$

$$P = \frac{76 \times (2000)^{1.4}}{(4000)^{1.4}} = 28.8\text{mmHG}$$

Under isothermal conditions

$PV = \text{constant}$

$$\Rightarrow 28.8 \times 4000 = P \times 3000$$

$$P = \frac{28.8 \times 4000}{3000} = 38.4\text{mmHg}$$

Hence final temperature and pressure are 222.1K and 38.4mmHg respectively

(ii) Indicate the two processes on a P-V diagram. (02 Marks)

(The ratio of the specific heat capacities of air = 1.4)

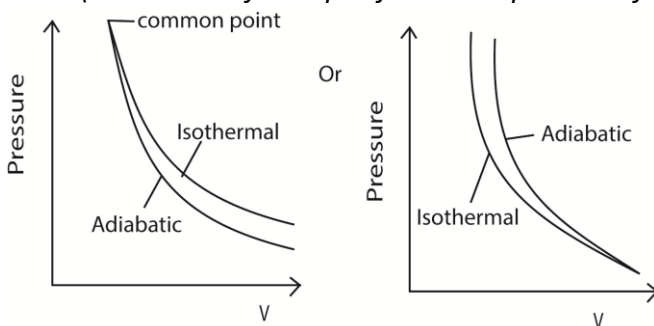

- (c) Show that the work done, W , by a gas in expanding from volume V_1 to V_2 at constant pressure, P , is $W = P(V_2 - V_1)$. (04 marks)

If the piston is moved through a small distance dx , so that the pressure P is constant then

$$dw = Fdx$$

$$\text{but } F = PA;$$

$$\Rightarrow dw = PAdx; \text{ also, } Adx = dv$$

$$\therefore dw = Pdv$$

$$\Rightarrow W = \int_{v_1}^{v_2} Pdv$$

$$= [PV]_{v_1}^{v_2}$$

$$= P(v_2 - v_1)$$

4. (a) Define the following:

(i) specific heat capacity (01 mark)

Specific heat capacity is the amount of heat required to raise the temperature of 1kg mass of a substance by 1K or 1°C

(ii) specific latent heat of vaporization. (01mark)

Specific latent heat of vaporization is the amount of heat energy required to change 1kg of a liquid to vapour at constant temperature.

(b) With the aid of a labelled diagram, describe an experiment to determine the specific latent heat of vaporization of a liquid. (07 marks)

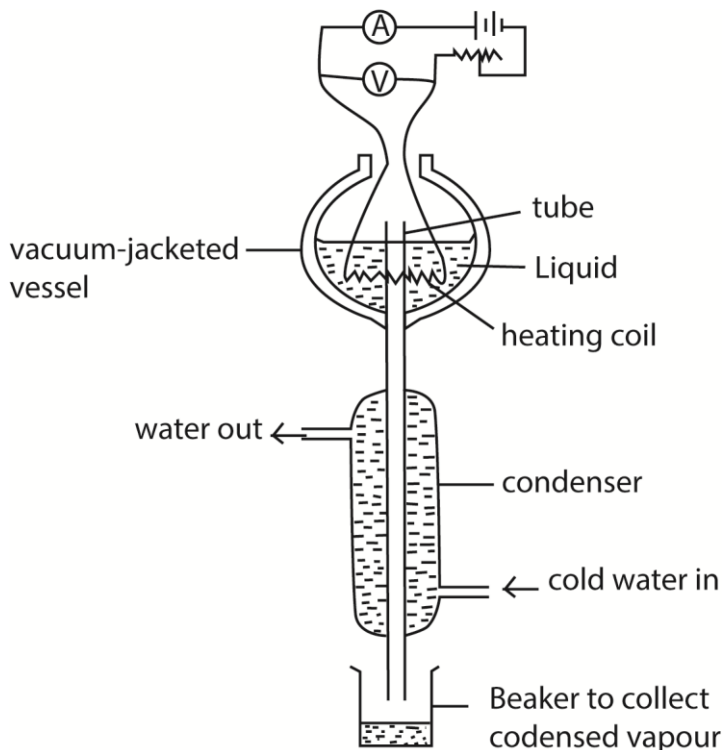

- Put the liquid whose specific latent heat of vaporization is required in a vacuum jacketed vessel as shown above.
- The liquid is heated to boiling point.
- The current, I , and voltage, V are recorded.

- The mass of liquid, m , condensed in time, t , is determined.
- Then $IV = \frac{m}{t}L + h$, where h is the rate of heat loss to the surroundings
- To eliminate, h , the experiment is repeated for different values of I' and V' and the mass of the liquid, m' condensed in time t is determined.
- Again $I'V' = \frac{m'}{t}L + h$

$$\text{Latent heat of vaporization, } L = \frac{(I'V' - IV)t}{(m' - m)}$$

(c) The inlet and outlet temperatures of water flowing in a continuous flow method are 15.2°C and 17.4°C respectively. A flow rate of 20 g min^{-1} is obtained when a current of 2.3A flows and a p.d of 3.3V is applied. When oil, which flows in and out at the same temperatures as water is used, the flow rate obtained is 70.0 g min^{-1} . Calculate the specific heat capacity of the oil, if a p.d 3.9V is applied and a current of 2.7A flows. (05 marks)

$VI t = mc\theta + h$ where h is the rate of heat loss

$$1.3 \times 2.3 = \frac{20}{1000 \times 60} \times 4200 \times (17.4 - 15.2) + h \dots\dots\dots (i)$$

$$3.9 \times 2.7 = \frac{70}{1000 \times 60} \times c \times (17.4 - 15.2) + h \dots\dots\dots (ii)$$

Subtracting (i) from (ii)

$$2.94 = 2.5667 \times 10^{-3} c - 3.08$$

$$c = 2345 \text{ J kg}^{-1} \text{ K}^{-1}$$

hence specific heat capacity of the liquid = $2,345 \text{ J kg}^{-1} \text{ K}^{-1}$

(d) Explain the effect of pressure on:

(i) boiling point of a liquid. (03marks)

When the liquid boils its saturated vapour pressure = external pressure and saturated vapour pressure increases with increasing temperature. When external pressure is raised, a liquid will boil at higher saturated pressure which occurs at high temperature.

(ii) Melting point of ice. (03 marks)

Increase in pressure lowers the melting point of ice because melting of ice is followed by a decrease in volume.

5. (a) Define the following:

(i) Molar heat capacity of a gas at constant pressure. (01mark)

The specific heat capacity of a gas at constant pressure is the heat required to warm unit mass of it by one degree, when its pressure is kept constant.

- (ii) Molar heat capacity of a gas at constant volume. (01mark)
 (iii) Define molar heat capacity of a gas at constant volume. (01mark)

Molar heat capacity of a gas at constant volume is the amount of heat required to raise 1 mole of the gas through 1K at constant volume.

- (b) Derive the expression $C_p - C_v = R$, where C_p is the molar heat capacity of a gas at constant pressure and C_v is the molar heat capacity of a gas at constant volume and R is the gas constant. (05marks)

From $dQ = dU + dW$ (i)
 But $dQ = C_p dT$, $dU = C_v dT$ and $dW = PdV = RdT$
 Substituting in (i)
 $C_p dT = C_v dT + RdT$
 $\therefore C_p - C_v = R$

- (c) (i) Differentiate between **adiabatic** and **isothermal** expansions. (02marks)

Isothermal expansion occurs at constant temperature.

Adiabatic expansion occurs at no heat input or output in the system.

- (ii) State **two** examples of adiabatic changes. (01marks)

Expansion of a gas in an insulated cylinder.

release of air from a pneumatic tire.

rapidly pumping air into a bicycle tire.

- (d) A fixed mass of an ideal gas of volume 400cm^3 at 15°C expands adiabatically and its temperature falls to 0°C . It is then compressed isothermally until the pressure returns to its original value. If the molar heat capacity at constant pressure is $28.6 \text{ J mol}^{-1}\text{K}^{-1}$, calculate the final volume after isothermal compression. (05marks)

Solution

Under adiabatic expansion

Initial temperature = $273 + 15 = 288\text{K}$

Final temperature = $273 + 0 = 273\text{K}$

$C_p = C_v + R = 28.6 + 8.31 = 36.91\text{J}$

$\gamma = \frac{c_p}{c_v} = \frac{36.91}{28.6} = 1.29$

Final volume (V) under adiabatic condition

$T_1 V_1^{\gamma-1} = T_2 V_2^{\gamma-1}$

$\Rightarrow 288(4000)^{1.29-1} = 273(v)^{1.29-1}$

$$V = \sqrt[0.29]{\frac{288(4000)^{0.29}}{273}} = 4810.2 \text{ cm}^3$$

Final pressures(P_2) under adiabatic condition

$$P_1 V_1^\gamma = P_2 V_2^\gamma$$

$$P \times (4000)^{1.29} = P_2 \times (4810.2)^{1.29}$$

$$P_2 = \frac{P \times (4000)^{1.29}}{4810.2^{1.29}} = 0.7883P$$

Final volume under isothermal conditions

$$PV = \text{constant}$$

$$\Rightarrow 0.7883P \times 4810.2 = P \times v$$

$$V = 3,792 \text{ cm}^3$$

Hence final volume = 3.792 cm^3

(e) (i) What is **saturated vapour pressure** of a liquid? (01mark)

A saturated vapour is one that is a dynamic equilibrium with its own liquid

(ii) Describe an experiment to show that a liquid boils when its saturated vapour pressure equals to the atmospheric pressure. (04marks)

The setup is shown below

Experiment to show that a liquid boils off when its saturated vapour pressure equals the external pressure

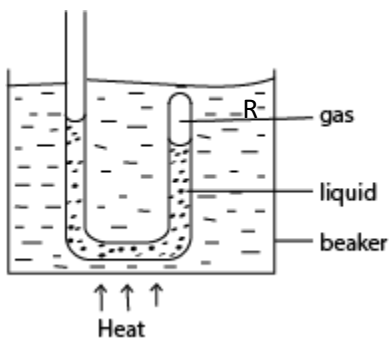

- Air is trapped in the closed limb of the tube by water column.
- The tube is heated in water bath.
- When the water bath begins to boil, the water in the tube comes to the same level in each limb.
- This shows that the vapor pressure in closed limb is equal to external pressure

Hence water boils when its saturated vapour pressure is equal to atmospheric pressure.

6. (a) Define the following:

(i) Temperature gradient (01 mark)

A **temperature gradient** refers to the rate of change in temperature with respect to distance.

(ii) Thermal conductivity. (01 marks)

Thermal conductivity is the rate of heat flow per unit cross section area per unit temperature gradient.

(b) Explain why a poor conductor whose thermal conductivity is to be determined, must be thin and fairly of large surface area. (03marks)

Thin Sample:

- **Reduced Heat Flow Path:** A thinner sample ensures that the heat travels a shorter distance from the hot side to the cold side. This allows for a more accurate measurement of the temperature gradient and, consequently, the thermal conductivity.
- **Minimized Thermal Resistance:** A thin sample minimizes the internal thermal resistance, which helps in obtaining more precise results.

Large Surface Area:

- **Enhanced Heat Transfer:** A larger surface area increases the amount of heat transferred across the sample, making it easier to detect and measure the temperature change.
- **Reduced Edge Effects:** A larger surface area ensures that the heat flow is predominantly one-dimensional and minimizes the impact of edge effects, which can distort the measurement.

(c) With the aid of a labelled diagram, describe how the presence of radiation is detected by a bolometer connected to Wheatstone bridge. (06marks)

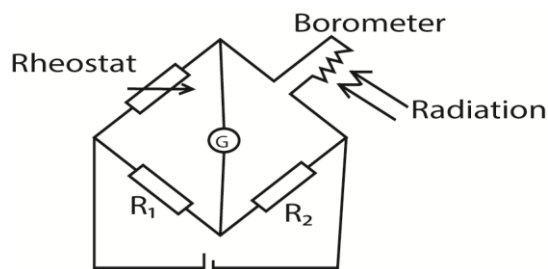

The bolometer strip is connected to Wheatstone bridge circuit above. The rheostat is adjusted until the galvanometer shows no deflection. When the radiations fall on the strip, they are absorbed and its temperature rises leading to an increase in resistance. The galvanometer deflects showing the presence of radiations.

- (d) A metal sphere whose surface acts as a black body is placed at the principal focus of a concave mirror of diameter 60cm, which is directed towards the sun. If the solar radiation falling normally on the earth is 1400Wm^{-2} , and the mean temperature of the surrounding is 30°C , find the diameter of the sphere when the maximum temperature it attains is 1870°C . (06marks)

$$\text{Area of the mirror} = \pi r^2 = \pi(0.3)^2 = 0.2827\text{m}^2$$

$$\text{Power reflected by the mirror per second} = 0.2827 \times 1400 = 396\text{W}$$

$$P = A\sigma(T_1^4 - T_2^4)$$

$$T_1 = 1870 + 273 = 2,143\text{K}$$

$$T_2 = 30 + 273 = 303\text{K}$$

Let the diameter of the sphere be d

$$396 = \pi d^2 \times 5.67 \times 10^{-8}(2,143^4 - 303^4)$$

$$d = 0.01\text{m}$$

- (e) State **three** properties of radiant energy. (03marks)

- produce ionization and fluorescence
- affect photographic plates
- produces photoelectric effect
- promotes chemical reaction
- can be reflected and refracted.

7. (a) Define the following:

- (i) Triple point of water (01 marks)

It is the temperature and pressure at which a vapour, liquid and solid of a substance coexist at equilibrium.

- (ii) Absolute zero temperature (01mark)

It is the minimum temperature on thermodynamic scale i.e. 0K.

- (b) Explain why triple point of water is taken as a standard in modern thermometry instead of ice and steam points. (04 marks)

It is constant, reproducible and not affected by pressure variations and impurities in water.

- (c) (i) What is a **thermometric property**? (01 marks)

Thermometric property is a physical measurable property that varies linearly and continuously with temperature and is constant at constant temperature.

- (ii) State **three** qualities of a good thermometric property? (03mark)

- should vary linearly with change in temperature

- Should vary continuously with temperature
- Should be sensitive to temperature changes
- Should be measurable
- Should vary over a wide range of temperature.

(d)(i) a constant volume thermometer was used to measure temperature when the atmospheric pressure was 760mmHg.

The following values were obtained.

	Length of Mercury in closed limb (mmHg)	Length of Mercury in open limb (mmHg)
Bulb in ice	140	130
Bulb in steam	140	330
Bulb at room temperature	140	170

Calculate the room temperature. (05marks)

$$\text{Room temperature} = \frac{170-130}{330-130} \times 100 = 20^{\circ}\text{C}$$

(ii) List two advantages of the constant volume gas thermometer over the mercury in glass thermometer. (02 marks)

- it has a wide range
- very accurate
- very sensitive

(e) Explain what happens when the temperature of a fixed mass of ice is raised from 0⁰C to 10⁰C. (03marks)

- Temperature remains constant until all the ice has melted and then temperature of water increases to from 0⁰C to 10⁰C.
- The volume decreases up to 4⁰C and then increase as temperature increases to 10⁰C.

8. (a) Define specific heat capacity. (01 mark)

Specific heat capacity is the amount of heat requires raising the temperature of 1kg mass of a substance by 1K or 1⁰C

(b) Describe, stating the assumptions made, an electrical method for the determination of the specific heat capacity of a metal. (08marks)

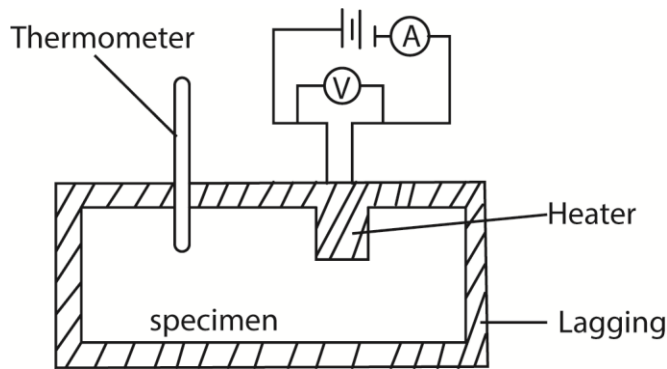

- Two holes are drilled into the specimen solid of copper of mass m .
- A thermometer is inserted in one of the holes and an electric heater into the other hole. The holes are then filled with a good conducting fluid, e.g. oil to ensure thermal contact.
- The apparatus is insulated and initial temperature θ_0 is recorded.
- The heater is switched on at the same time a stop clock is started.
- The steady values of ammeter reading, I and voltmeter reading, V are recorded.
- After considerable temperature rise, the heater is switched off and stop clock stopped.
- The highest temperature θ_1 recorded and time t taken noted.
- The specific heat capacity, c , of the conducting solid is calculated from

$$c = \frac{IVt}{m(\theta_1 - \theta_0)}$$

Assumption

- no heat loss
- metal has good conductivity
- there is good heat transfer from the heater to the metal

(c) In an experiment to determine specific heat capacity of a liquid using the continuous flow calorimeter;

(i) the readings are taken when the apparatus has attained a steady state. Explain the meaning of a steady state. (02marks)

A steady rate occurs when the inlet and outlet thermometer readings and flow rates are constant.

(ii) Explain why two sets of readings are taken. (01 mark)

To account for heat losses.

(d) When water is passed through a continuous flow calorimeter at the rate of 100 g min^{-1} , the temperature rises from 16°C to 20°C , when the p.d. across the heater is 20V and the current is 1.5A . When another liquid at 16°C is passed through the calorimeter at the rate of 120 g min^{-1} , the same temperature change is obtained at a p.d. of 30V and current 1.2A . Calculate the specific heat capacity of the liquid. (04 marks)

Rate of dissipation heat = rate at which heat gained by water + rate of heat loss (h)

$$VI = mc\theta + h$$

$$20 \times 1.5 = \frac{100}{60 \times 1000} \times c \times (20 - 16) + h \dots\dots\dots(i)$$

$$30 \times 1.2 = \frac{120}{60 \times 1000} \times c \times (20 - 16) + h \dots\dots\dots(ii)$$

Eqn (ii) – eqn. (i)

$$6 = \frac{20}{60 \times 1000} \times c \times 4$$

$$c = 4,500 \text{Jkg}^{-1}\text{K}^{-1}$$

Hence specific heat capacity of the liquid is $4,500 \text{Jkg}^{-1}\text{K}^{-1}$.

(e) (i) Define latent heat. (01 mark)

Specific latent heat of fusion is the amount of heat required to change 1kg mass of a substance from solid to liquid without change of temperature.

(ii) Explain why latent heat of vaporisation is always greater than that of fusion

Latent heat of fusion only supply energy to breaks down the forces that keep ordered pattern of molecules is solid crystalline structure to form a liquid. The potential energy of the molecules increase but the average kinetic energy and temperature of the molecules remain unchanged.

While,

Latent heat of vaporization is always greater than latent heat of fusion because it supplies both energy to break down stronger molecular bonds in liquids and to provide energy to liquid molecules in order to expand into gas molecules against atmospheric pressure.

9. (a) (i) Explain how a thermocouple is used to measure temperature on a Celsius scale. (05marks)

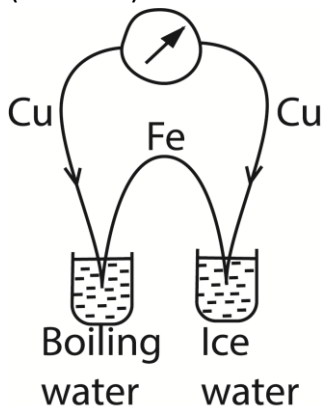

The e.m.f, E_{Tr} is obtained when a hot junction is placed in water at triple point. E.m.f, E_T is obtained at unknown temperature T.

$$T = \frac{E_T}{E_{Tr}} \times 273.16K$$

(ii) State two advantages of a thermocouple. (01mark)

- Used to measure rapidly changing temperature
- It can give direct readings
- It is not bulky
- It can measure temperature at a point

(b) (i) Two cylindrical bodies A and B are made of the same material but the length of A is twice that of B and the cross sectional area of B is a third that of A. If the ends of A and B are subjected to same temperature difference, find the ratio of the rate of heat flow through A to the rate of heat flow through B. (03marks)

$$\text{Rate of heat flow } Q = k \cdot A \cdot \frac{\Delta T}{L}$$

Where

k = thermal conductivity of the material (which is the same for both A and B)

A = the cross-sectional area

ΔT = temperature difference

L = length of the material

$$\frac{Q_A}{Q_B} = \frac{k \cdot A \cdot \frac{\Delta T}{2L}}{k \cdot \frac{1}{3}A \cdot \frac{\Delta T}{L}} = \frac{1}{2} \times \frac{3}{1} = \frac{3}{2}$$

Hence the ratio of the rate of heat flow through A to the rate of heat flow through B = 3:2

(ii) In the determination of thermal conductivity of copper, when water flows round the cool end of a copper rod at a rate of 600cm^3 per minute, its temperature increases by 3.3°C . the temperature at two points, a distance 5.2cm apart, along the copper rod are 70°C and 30°C respectively. Find the thermal conductivity of copper if the radius of the rod is 1.2cm .

$$\frac{Q}{t} = kA \left(\frac{\theta_2 - \theta_1}{L} \right) = mc_w(\theta_4 - \theta_3)$$

$$\text{Mass of water } m \text{ kgs}^{-1} = \frac{600}{60 \times 1000} = 0.01$$

$$\text{Cross section area of copper rod} = \pi(1.2 \times 10^{-2})^2 = 4.5239 \times 10^{-4} \text{m}^2$$

$$\Rightarrow k \times 4.5239 \times 10^{-4} \left(\frac{70 - 30}{0.052} \right) = 0.01 \times 4200 \times 3.3 = 398.3 \text{Wm}^{-1}\text{K}^{-1}$$

(c) Describe an experiment to measure thermal conductivity of cork. (07marks)

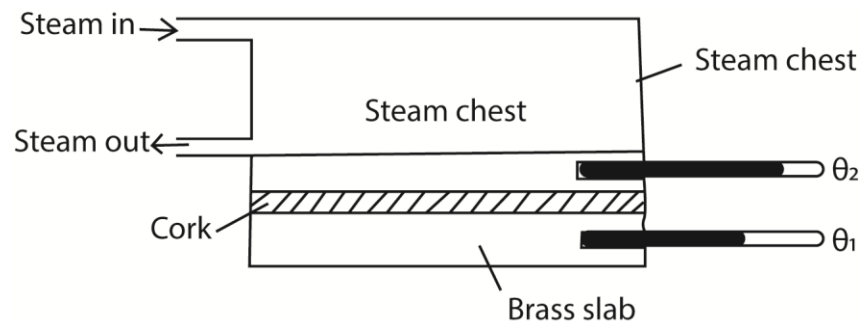

- Cork is cut in form of a thin disc of cross section area, A and thickness, x.
- The disc is sandwiched between a steam chest and brass slab of mass, m and specific heat capacity, c.

- Steam is passed through the chest until the thermometers register steady temperatures, θ_1 and θ_2 .
- Then, $\frac{\theta}{t} = kA \left(\frac{\theta_2 - \theta_1}{x} \right)$
- The glass disc is removed and brass slab is heated directly by steam chest, until its temperature is about 10°C above θ_1 .
- Steam chest is removed and the top of the glass slab is covered by the cork disc.
- The temperature of the slab is recorded at suitable time interval until its temperature is about 10°C below θ_1 .
- A graph of temperature against time is plotted and its slope s determined at θ_1

$$\frac{\theta}{t} = mcs$$

$$\therefore kA \left(\frac{\theta_2 - \theta_1}{x} \right) = mcs$$

$$k = \frac{mcsx}{A(\theta_2 - \theta_1)} \text{ but } A = \frac{\pi D^2}{4}$$

$$\therefore k = \frac{4mcsx}{\pi D^2(\theta_2 - \theta_1)}$$

10. (a) (i) State any three properties of ultraviolet radiation. (03marks)

- Produces ionization
- Produces fluorescence
- Affects photographic films
- Produces photoelectric effect
- Absorbed by glass
- Can be polarized
- Promotes chemical reactions

(ii) What is a black body? (01mark)

A black body is one that absorbs all radiations incident on it without reflecting nor transmitting any.

(b) A cylindrical metal rod with a well-insulated curved surface has one end blackened and then exposed to thermal radiation from a body at a temperature 500K . If the equilibrium temperature of the blackened end is 400K and the length of the rod is 10cm , calculate the temperature of the other end. [Thermal conductivity of the metal = $500\text{Wm}^{-1}\text{K}^{-1}$] (04marks)

$$\begin{aligned} \text{Power absorbed} &= \sigma A(T_2^4 - T_1^4) \\ &= 5.67 \times 10^{-8} A(500^4 - 400^4) \\ &= 2092.13A \end{aligned}$$

$$\begin{aligned} \text{Power conducted} &= \frac{Q}{t} = KA \frac{\Delta\theta}{L} \\ &= \frac{A(400 - T)}{10} \times 500 = 50(400 - T)A \end{aligned}$$

Power absorbed = power conducted

$$50(400 - T)A = 2092.13A$$

$$T = 358.16\text{K}$$

(c) (i) Describe Electrical method of determining the specific heat capacity of a good conducting solid. (06marks)

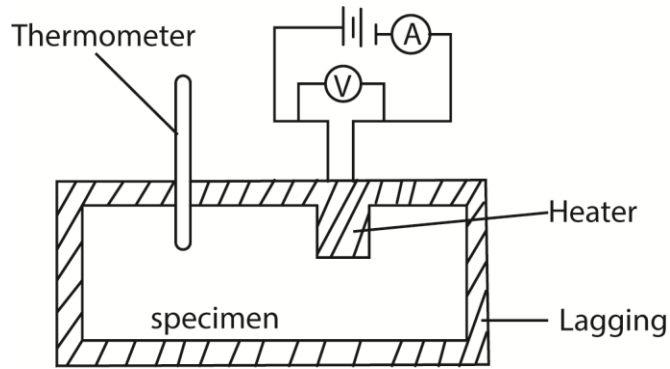

- Two holes are drilled into the specimen solid of mass m .
- A thermometer is inserted in one of the holes and an electric heater into the other hole. The holes are then filled with a good conducting fluid, e.g. oil to ensure thermal contact.
- The apparatus is insulated and initial temperature θ_0 is recorded.
- The heater is switched on at the same time a stop clock is started.
- The steady values of ammeter reading, I and voltmeter reading, V are recorded.
- After considerable temperature rise, the heater is switched off and stop clock stopped.
- The highest temperature θ_1 recorded and time t taken noted.
- The specific heat capacity, c , of the conducting solid is calculated from

$$c = \frac{IVt}{m(\theta_1 - \theta_0)}$$

(ii) Give two reasons why the value obtained using the method in (c)(i) may not be accurate.

(02marks)

- some heat is lost to the surrounding through the insulator
- some heat is absorbed by the thermometer and heater
- the solid expands during heating and so external work is done against atmospheric pressure.

(d) Explain why cloudy nights are warmer than cloudless ones.

During day, radiation is absorbed from the sun by earth. At night, the earth radiated heat into the atmosphere.

On a cloudless night, the radiated heat is lost. On cloudy night, the clouds form blanketing layer which reflects back the heat to the earth and warmth feeling.

11. (a)(i) What is meant by a reversible process? (02marks)

A reversible process is a process that can proceed in a reverse direction by very small change in conditions making it take place through exactly same steps.

(ii) Distinguish between a saturated vapour and unsaturated vapour. (02marks)

A saturated vapour is one that is a dynamic equilibrium with its own liquid while unsaturated vapour is not in

(iii) Explain why evaporation causes cooling(03marks)

When a liquid vaporizes, it absorbs latent heat of vaporization from the body from which evaporation occurs. Hence the body cools.

(b) Describe an experiment to determine the temperature dependence of saturated vapour pressure of water. (07marks)

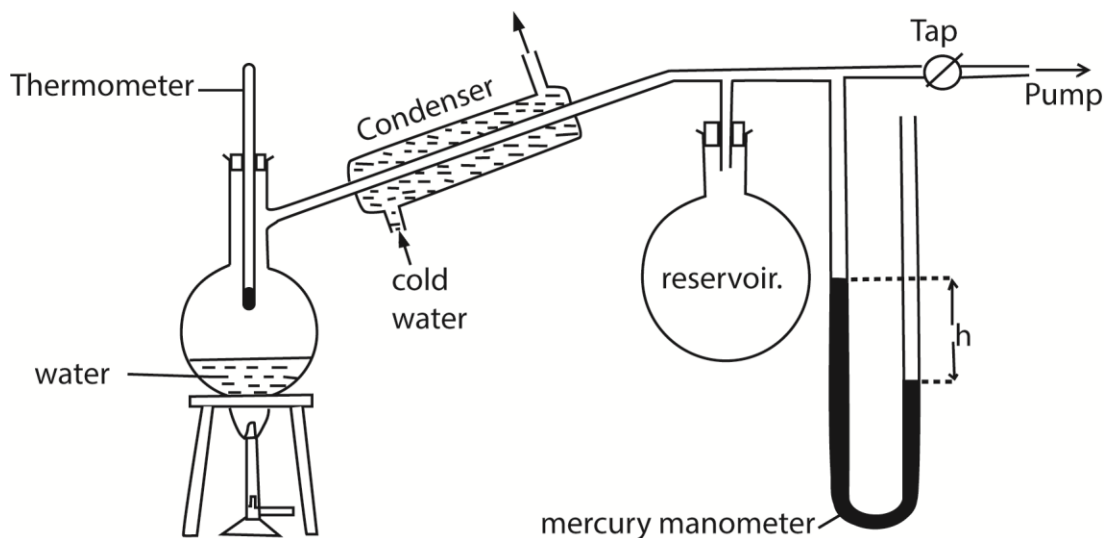

- The pressure of the air in R is shown by the mercury manometer; if its height is h , the pressure in mm mercury is $P = H-h$, where H is the barometer height.
- The tap is opened and the pressure above water varied using the pump to a suitable value.
- The tap is closed and water in the flask is heated until it boils.
- The temperature θ and difference in mercury levels, h , are noted and recorded.
- The saturated vapour pressure, $P = (H \pm h)$ is calculated
- The procedure is repeated for other values of θ and h
- A graph of P versus θ is plotted and it shows that saturated vapour pressure, P , increases with temperature, θ .

(c) (i) State Dalton's law of partial pressures. (07marks)

Dalton's law states that the total pressure of a mixture of gases that do not react chemically is equal to the sum of the partial pressures of the components of a gas.

(ii) A sealed container has liquid water, water vapour and air all at 27°C . The total pressure inside the container is 69cmHg . When the temperature is raised to 85°C , the total pressure changes to 96cmHg . If the saturated vapour pressure of water at 27°C is 5cmHg and water vapour remains saturated, calculate the saturated vapour pressure of water at 85°C .

(05marks)

$$T_1 = 27 + 273 = 300\text{K}$$

$$T_2 = 85 + 273 = 358\text{K}$$

$$\text{Partial pressure at } T_1; P_1 = 69 - 5 = 64\text{cmHg}$$

$$\text{Partial pressure at } T_2, P_2 = (96 - P)\text{cmHg}$$

$$\text{Using } \frac{P_1 V_1}{T_1} = \frac{P_2 V_2}{T_2} \text{ but } V_1 = V_2 = V$$

$$\frac{64V}{300} = \frac{(96 - P)V}{358}$$

$$P = 19.63\text{cmHg}$$

12. (a) Define the following:

(i) Thermal conductivity. (01marks)

Thermal conductivity is the rate of heat flow per unit cross section area per unit temperature gradient

(ii) Specific latent heat of vaporization. (01mark)

Specific latent heat of vaporization is the amount of heat energy required to change 1kg of a liquid to vapour at constant temperature.

(b) A boiler with a base made of rod steel 15cm thick, rests on a hot stove. The area of the bottom of the boiler is $1.5 \times 10^3 \text{ cm}^2$. The water inside the boiler is at 100°C . If 750g of water is evaporated every 5 minutes, find the temperature of the surface of the boiler in contact with the stove. [Thermal conductivity of steel = $50.2 \text{ Wm}^{-1}\text{K}^{-1}$, specific latent heat of vaporization of water = $2.26 \times 10^6 \text{ Jkg}^{-1}$]

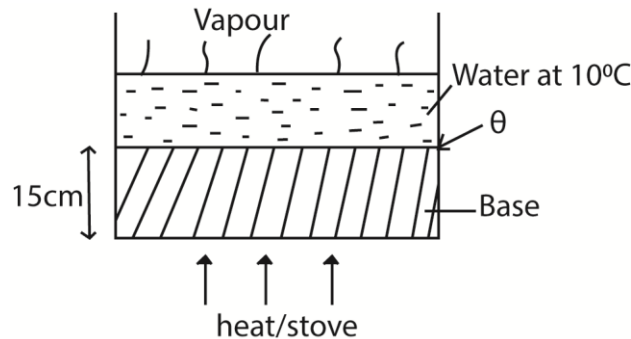

Rate of heat flow through the boiler = Rate of heat supplied to vaporize water

$$kA \frac{\Delta\theta}{L} = \frac{ml_v}{t}$$

$$\frac{50.2 \times 0.15(\theta - 100)}{15 \times 10^{-2}} = \frac{0.75 \times 2.26 \times 10^6}{5 \times 60}$$

$$\theta = 2128^\circ\text{C}$$

(c) Hot water in a metal tank is kept constant at 65°C by an immersion heater in the water. The tank has lagging all around it of thickness 20mm and thermal conductivity $0.04 \text{ Wm}^{-1}\text{K}^{-1}$ and its surface area is 0.5 m^2 . The heat lost per second by the lagging is 0.8W per degree excess above the surroundings. Calculate the power of immersion heater if the temperature of the surroundings is 15°C . (05marks)

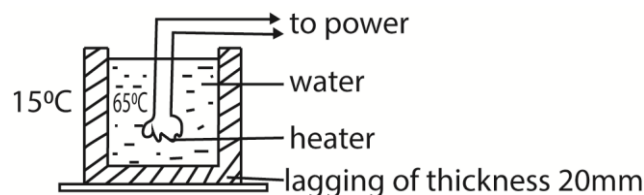

$$K = 0.04 \text{ Wm}^{-1}\text{K}^{-1}, A = 0.5 \text{ m}^2, L = 20 \times 10^{-3} \text{ m}$$

Let θ be the temperature of the lagging

$$\text{Excess temperature} = (\theta - 15)$$

$$\text{Heat lost per second} = 0.8(\theta - 15)$$

$$\text{The rate of heat flow} = KA \frac{\Delta\theta}{L} = 0.04 \times 0.5 \times \frac{(65 - \theta)}{20 \times 10^{-3}}$$

At steady state

Heat lost per second = Rate of heat flow

$$0.8(\theta - 15) = 0.04 \times 0.5 \times \frac{(65 - \theta)}{20 \times 10^{-3}}$$

$$\theta = 42.8^\circ\text{C}$$

$$\text{Power of heater} = 0.8(42.8 - 15) = 22\text{W}$$

(d)(i) Define thermometric property (01mark)

Thermometric property is a physical measurable property that varies linearly and continuously with temperature and is constant at constant temperature.

(ii) Define how a liquid-in-glass thermometer can be used to measure temperature in degrees Celsius. (04marks)

- A bulb is inserted in pure ice-water mixture.
- After some time, the length l_0 of mercury thread is recorded.
- The bulb is inserted in steam and constant length l_{100} of mercury thread is recorded.
- When l_θ is the length of mercury thread inserted in an unknown enclosure of temperature, θ° , then;

$$\theta = \left(\frac{l_\theta - l_0}{l_{100} - l_0} \right) \times 100^\circ\text{C}$$

(iii) A thermometer is constructed with a liquid which expands according to relation. $V_t = V_0(1 + \alpha t + \beta t^2)$. Where V_t is the volume at $t^\circ\text{C}$ and V_0 is the volume at 0°C on the scale of the gas thermometer and α and β are constants.

Given that $\alpha = 1000\beta$, what will the liquid thermometer read when the gas thermometer reads 50°C .

$$\text{Using } \theta = \left(\frac{V_\theta - V_0}{V_{100} - V_0} \right) \times 100^\circ\text{C}$$

$$V_{50} = V_0(1 + \alpha(50) + \beta(50)^2).$$

$$V_{100} = V_0(1 + \alpha(100) + \beta(100)^2).$$

$$\theta = \left(\frac{V_0(1 + 50000\beta + 2500\beta) - V_0}{V_0(1 + 100000\beta + 10000\beta) - V_0} \right) \times 100^\circ\text{C}$$

$$= 47.73^\circ\text{C}$$

13. (a) Define the following quantities:

(i) Thermometric property (01mark)

Thermometric property is a physical measurable property that varies linearly and continuously with temperature and is constant at constant temperature.

(ii) Specific heat capacity (01mark)

Specific heat capacity is the amount of heat requires to raise the temperature of 1kg mass of a substance by 1K or 1°C

(b) (i) state two examples of commonly used thermometric properties. (01mark)

- Volume of constant mass of a gas at constant pressure
- Pressure of a gas at constant volume
- Electrical resistance of a platinum wire
- e.m.f of a thermocouple

(ii) Describe briefly how to determine the lower and upper fixed points for an uncalibrated liquid-in-glass thermometer (04marks)

- the bulb of the thermometer is immersed in pure ice-water mixture; the level of liquid column falls to a constant length. The level of the liquid column is marked and is the lower fixed point.
- the bulb of the thermometer is then immersed in steam from pure water; the level of liquid column rises to a constant length. The level of the liquid column is marked and is the upper fixed point.

(c) (i) Describe with the aid of a diagram, an experiment to determine the specific heat capacity of a liquid using the continuous flow method. (07marks)

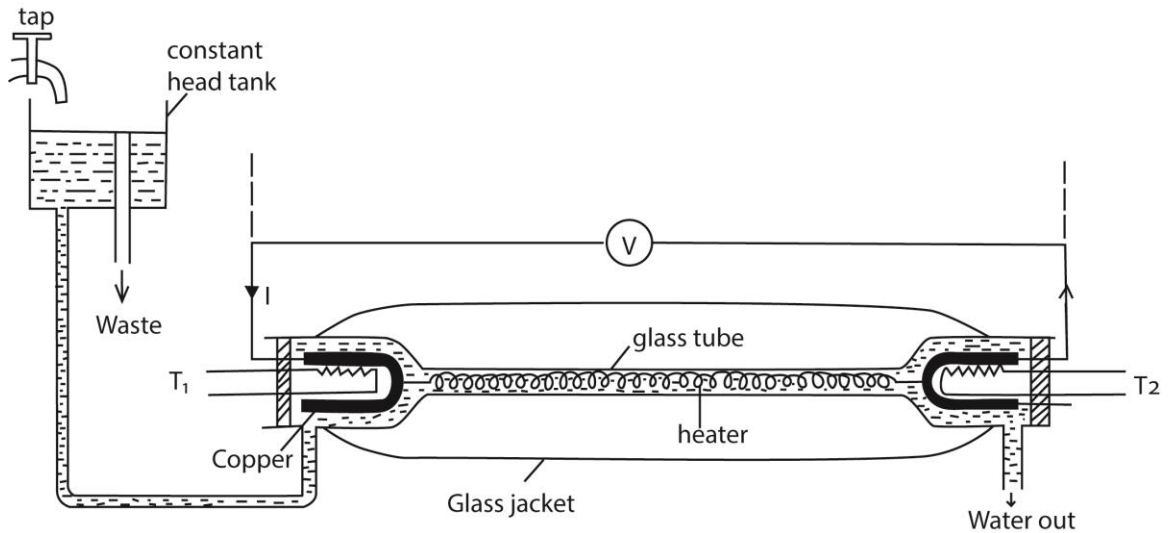

- A liquid is allowed to flow at constant rate
- Power is switched on and the liquid is heated until temperatures registered by T_1 and T_2 are steady and the values θ_1 and θ_2 respectively are recorded.
- The p.d V and current I are recorded from the voltmeter and ammeter respectively
- The mass, m of a liquid collected in time t is recorded
- At steady state; $VIt = mc(\theta_2 - \theta_1) + h$ (i)
where h is heat lost to the surrounding
- The rate of flow is changed and the voltage and current are adjusted until the steady readings of T_1 and T_2 are θ_1 and θ_2 respectively
- If m_1 , V_1 and I_1 are the values mass of liquid collected in time t, voltmeter and ammeter readings respectively, then
 $V_1 I_1 t = m_1 c (\theta_2 - \theta_1) + h$ (ii)
Subtracting (ii) from (i)

$$c = \frac{(V_1 - V_2)I_1 t}{(m - m_1)(\theta - \theta_1)}$$

(ii) State two advantages of the continuous flow method over the method of mixtures. (01mark)

- No cooling correction is required
- Heat capacity of the apparatus is not required
- Temperature measured at leisure when steady
- Resistance of the heater not required

(iii) State two disadvantages of the method in (c)(i) (01mark)

- larger volumes of liquid required
- not suitable for volatile liquids.

(d) The brake lining of the wheel of a car of mass 800kg have total mass of 4.8kg and are made of a material of specific heat capacity $1200\text{Jkg}^{-1}\text{K}^{-1}$. If the car is at 15ms^{-1} and is brought to rest by applying the brakes, calculate the maximum possible temperature rise of the brake lining. (04marks)

Mechanical energy = heat absorbed by the lining

$$\frac{1}{2}mv^2 = mc\theta \text{ where } \theta \text{ is temperature change}$$

$$\frac{1}{2} \times 800 \times 15^2 = 4.8 \times 1200 \times \theta$$

$$\theta = 15.6^\circ\text{C}$$

14. (a) (i) What is meant by conduction of heat? (01mark)

Conduction of heat is a process of heat transfer by which heat flows from a hotter region of a substance to the cold regions without the bulk movement of a substance as a whole.

(ii) Explain why mercury conducts heat better than water. (03marks)

Mercury has free electrons capable of transferring energy without any part of mercury moving. Mercury atoms are closer allowing conduction of atomic vibrations while in water there is no free electrons and atoms are farther apart.

(iii) Explain the occurrence of land and sea breezes. (06marks)

During day, the land is heated to a high temperature than the sea. Hot air expands and rises from land. A stream of cool air from the sea blows towards the land to replace the uprising air, hence sea breeze occurs.

At night the land cools faster because it is no longer heated by the sun. The sea retains the warmth because it is heated deeply. Warm less dense air rises from the sea surface and air from land blows to replace it leading to land breeze.

(b) A copper sphere of radius 7cm and density 900kgm^{-3} , is heated to a temperature of 127°C and then transferred to an evacuated enclosure whose walls are at a temperature of 27°C . Calculate

(i) net rate of loss of heat by the copper sphere

$$P = A\sigma(T_1^2 - T_0^2) = 4\pi R^2\sigma(T_1^2 - T_0^2) = 4\pi(0.07)^2 \times 5.67 \times 10^{-8} (400^4 - 300^4) = 61.122\text{Js}^{-1}$$

(ii) temperature of copper sphere after 5minutes

$$\text{Average rate of heat loss} = \frac{61.122+0}{2} = 30.6\text{Js}^{-1}$$

$$P = mc\frac{d\theta}{dt} = \frac{4}{3}\pi r^3 \rho c \frac{d\theta}{dt}$$

$$30.6 = \frac{4}{3}\pi(0.07)^3 \times 900 \times 400 \times \frac{d\theta}{dt}$$

$$\frac{d\theta}{dt} = 0.059\text{Ks}^{-1}$$

(c) Explain why heating system based on the circulation of steam are more efficient than those based on circulation of boiling water. (02marks)

A given mass of steam gives out more energy than an equal amount of water because of the specific latent heat.

15. (a) (i) what is meant by a black body? (02marks)

A black body is a body that absorbs all radiations incident on it and transmits and reflects none

(ii) Give two examples of a black body. (01mark)

- The sun
- Star
- Black hole (remnants of a star after it has used up all its energy)
- An almost enclosed blackened surface with hole/furnace with small hole

(b) With aid of graphs describe how radiation emitted by a black body varies with wavelength for two temperatures.

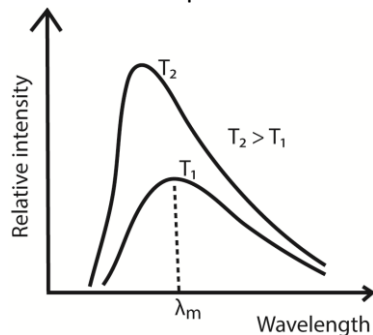

- For every wave length, relative intensity increases as temperature is increased.
- The wavelength at which maximum intensity occur shifts to the shorter wavelength as temperature is increased.
- λ_{max} is the wavelength of radiation emitted at maximum intensity/emission of a black body at a particular temperature.

(c) (i) Define thermal conductivity. (01mark)

Thermal conductivity is the rate of heat transfer per unit cross section area per unit temperature gradient.

(ii) Describe an experiment to determine thermal conductivity of glass. (07marks)

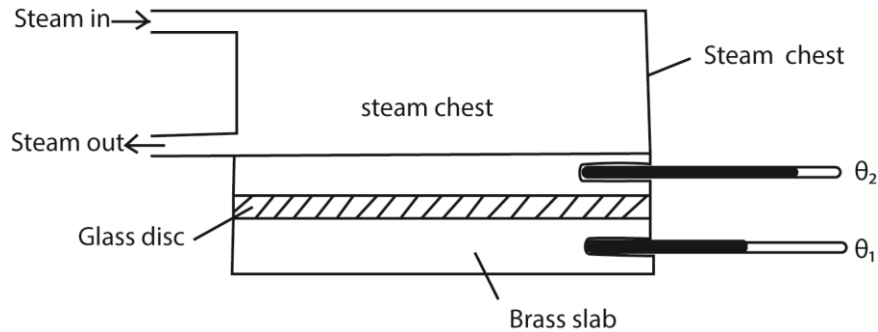

- Glass is cut in form of a thin disc of cross section area, A and thickness, x .
- The disc is sandwiched between a steam chest and brass slab of mass, m and specific heat capacity, c .
- Steam is passed through the chest until the thermometers register steady temperatures, θ_1 and θ_2 .
- Then, $\frac{\theta}{t} = kA \left(\frac{\theta_2 - \theta_1}{x} \right)$
- The glass disc is removed and brass slab is heated directly by steam chest, until its temperature is about 10°C above θ_1 .
- Steam chest is removed and the top of the glass slab is covered by the glass disc.
- The temperature of the slab is recorded at suitable time interval until its temperature is about 10°C below θ_1 .
- A graph of temperature against time is plotted and its slope s determined at θ_1

$$\frac{\theta}{t} = mcs$$

$$\therefore kA \left(\frac{\theta_2 - \theta_1}{x} \right) = mcs$$

$$k = \frac{mcsx}{A(\theta_2 - \theta_1)} \text{ but } A = \frac{\pi D^2}{4}$$

$$\therefore k = \frac{4mcsx}{\pi D^2(\theta_2 - \theta_1)}$$

- (d) Radiation from the sun falls normally on a blackened roof measuring $20\text{m} \times 50\text{m}$. If half of the solar energy is lost in passing through the earth's atmosphere, calculate the energy incident on the roof per minute. [Temperature of the sun's surface = 6000K ; radius of the sun = $7.5 \times 10^8\text{m}$, distance of the sun from the earth = $1.5 \times 10^{11}\text{m}$]

$$\text{Power radiated by the sun, } P = A\sigma T^4 = 4\pi r^2 \sigma T^4$$

$$\text{Power incident on sphere, } P_i = \frac{P}{2} = 2\pi r^2 \sigma T^4$$

$$\text{Power received by roof, } P_r = \frac{A_1}{A} \times P_i$$

$$= \frac{L \times w}{4\pi R^2} \times 2\pi r^2 \sigma T^4$$

$$= \frac{20 \times 50 \times 2\pi \times (7.5 \times 10^8)^2 \times 5.7 \times 10^{-8} \times 6000^4}{4\pi \times (1.5 \times 10^{11})^2}$$

$$= 923,400\text{W}$$

Energy incident on roof per minute

$$P_i = P_r \times 60 \text{ (1minute)}$$

$$= 923,400 \times 60$$

$$= 5.54 \times 10^7\text{J}$$

16. (a) (i) State the thermometric property used in a constant-volume gas thermometer (01mark)
pressure

(ii) Give two characteristic of a good thermometric property, (02marks)

- should vary linearly with change in in temperature
- Should vary continuously with temperature
- Should be sensitive to temperature changes
- Should be measurable
- Should vary over a wide range of temperature.

(b) (i) Describe the steps taken to set up a Celsius scale of temperature for a mercury-in glass thermometer. (04marks)

- A bulb is inserted in pure ice-water mixture.
- After some time, the length l_0 of mercury thread is recorded.
- The bulb is inserted in steam and constant length l_{100} of mercury thread is recorded.
- When l_θ is the length of mercury thread inserted in an unknown enclosure of temperature, θ° , then $\theta = \left(\frac{l_\theta - l_0}{l_{100} - l_0} \right) \times 100^\circ C$

(ii) State four disadvantages of a mercury in glass thermometer. (04marks)

- it is not very sensitive
- it cannot measure rapidly changing temperature
- it is delicate, i.e. it breaks easily

(c) Describe with the aid of a diagram the operation of an optical pyrometer (06marks)

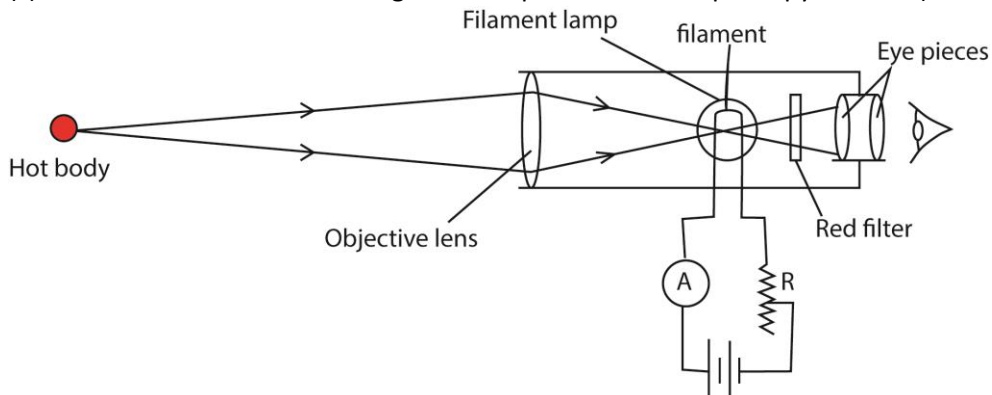

- the filament is focused on the eye piece and the objective focuses the object so that the image of the object lies in the same plane as the filament
- Light from the hot object and the filament is passed through the red filter and viewed by the eyepiece.
- Current is adjusted by the rheostat R until the filament and the object are equally bright.
- The temperature of the hot body is then read from the calibrated ammeter, A.

(d) When oxygen is withdrawn from a tank of volume 50L, the reading of pressured gauge attached to the tank drops from 4.4×10^5 Pa to 7.8×10^5 Pa. If the temperature of gas remaining in the tank falls from $30^\circ C$ to $10^\circ C$, calculate the mass of oxygen withdrawn.

$$PV = nRT$$

$$n_1 = \frac{P_1 V}{RT_1} = \frac{21.4 \times 10^5 \times 50 \times 10^{-3}}{8.31 \times 303} = 42.5 \text{ moles}$$

$$n_2 = \frac{7.8 \times 10^5 \times 50 \times 10^{-3}}{8.31 \times 283} = 16.6 \text{ moles}$$

$$\text{Change in mass, } \Delta m = (n_1 - n_2)MR$$

$$= (42.5 - 16.6) \times 32$$

$$= 828.8 \text{ g}$$

17. (a)(i) What is meant by boiling point? (01marks)

The boiling point of a liquid is the temperature at which its saturated vapour pressure equals the external pressure.

(ii) Explain why boiling point of a liquid increases with increase in the external pressure. (05marks)

When the liquid boils its saturated vapour pressure = external pressure and saturated vapour pressure increases with increasing temperature. When external pressure is raised, a liquid will boil at higher saturated pressure which occurs at high temperature.

(b) (Explain how the pressure of a fixed mass of a gas can be increased at

(i) Constant temperature (03marks)

By reducing the volume occupied by a gas, the molecules take less time to move between the walls of the container as the distance is reduced. The number of collisions per unit area increases hence pressure increases at constant temperature.

(ii) Constant volume (03marks)

By heating the gas, the molecules gain more kinetic energy. The molecules will bombard the walls many times per unit time per unit area. The total rate of change of momentum will increase hence pressure will increase

(c) Sketch a pressure versus volume curve for a real gas undergoing compression (03 marks)

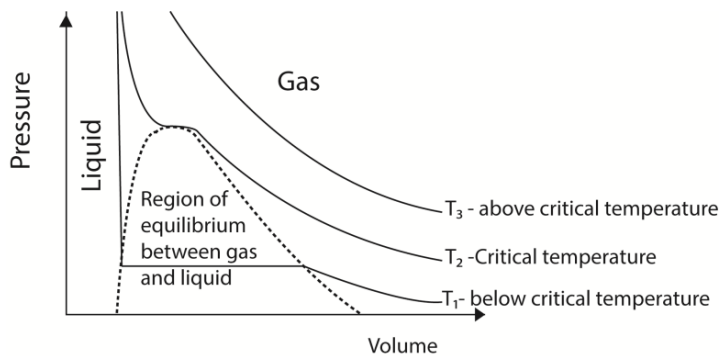

- Above the critical temperature a gas obeys Boyle's law.
- Below the critical temperature a gas exist as unsaturated vapour at low pressure when the pressure is increase it condenses until all the gas is turned into a liquid.

(d) The cylinder of an exhaust pump has a volume of 5 cm^3 . If it is connected through a valve to a flask of volume 225 cm^3 containing air at a pressure of 75 cmHg , calculate the pressure of air

in the flask after two strokes of the pump, assuming that the temperature of the air remain constant.

First stroke

$$P_1V_1 = P_2V_2 \text{ but } V_2 = 225 + 25 = 250\text{cm}^2$$

$$75 \times 225 = P_2 \times 250$$

$$P_2 = 67.5\text{cmHg}$$

Second stroke

$$P_2V_2 = P_3V_3$$

$$P_3 = \frac{67.5 \times 225}{250} = 60.8\text{cmHG}$$

Alternatively

$$P_n = \left(\frac{V_2}{V_1 + V_2} \right)^n P, \text{ n = number of strokes}$$
$$= \left(\frac{225}{225+25} \right)^2 \times 75 = 60.75\text{cmHg}$$

18. (a) (i) Define thermal conductivity. (01mark)

Thermal conductivity is the rate of heat flow per unit cross sectional area per unit temperature gradient.

(ii) Explain the mechanism of heat transfer by convection. (03marks)

When a fluid is heated from underneath, it expands and becomes less dense than fluid above. The warm less dense fluid rises to the top and the cool more dense fluid from above moves downwards to take place. This process continues and circulating current of the fluid is established until the whole fluid is heated up.

(b) (i) State Newton's law of cooling (01mark)

It states that the rate of loss of heat is proportional to the excess temperature between the body and the surroundings under forced convections or steady draught.

(ii) Describe briefly an experiment to verify Newton's law of cooling. (05marks)

Hot water in a calorimeter is placed near an open window. The temperature of the water is recorded at suitable time intervals. A graph of temperature against time is plotted.

Slope of the graph is obtained at temperature θ_1 . More values of the slope are obtained at different temperatures, $\theta_2, \theta_3, \theta_4$

For each temperature, excess temperature, $(\theta - \theta_R)$ is calculated, where θ_R is the room temperature.

A graph of slopes against excess temperature is plotted.

A straight line graph through the origin verifies Newton's law.

(c) A wall is constructed using two types of bricks. The temperatures of the inner and outer surface of the wall are 29°C and 21°C respectively. The value of thermal conductivity for the inner brick is $0.4\text{Wm}^{-1}\text{K}^{-1}$ and that of the outer brick is $0.8\text{Wm}^{-1}\text{K}^{-1}$.

(i) Explain why in a steady state the rate of thermal energy transfer is the same in both layers. (02marks)

No heat is lost to the surrounding as it flows through the inner and outer surfaces. The temperature gradient across the composite wall is constant.

(ii) If each layer is 12 cm thick, find the temperature at the interface between the layers.

(04mrks)

$$\text{From } \frac{Q}{t} = \frac{KA(\theta_2 - \theta_1)}{l_0}$$

$$\frac{0.4A(29 - \theta)}{12 \times 10^{-2}} = \frac{0.3A(\theta - 21)}{12 \times 10^{-2}}$$

$$\therefore \theta = 23.7^\circ\text{C}$$

(d) Explain the greenhouse effect and how it leads to rise of the earth temperature. (04marks)

The short wavelength radiation from the sun penetrates the atmosphere and is absorbed by the earth's surface. This absorbed energy warms the earth which then re-radiates long wavelength radiations e.g. infrared radiation. Some of this radiated energy absorbed (trapped) by the atmosphere. This leads to increased temperature on the earth with time referred to as global warming.

19. (a) (i) Define specific latent heat of fusion (01mark)

Specific latent heat of fusion is the amount of heat required to change 1kg mass of a substance from solid to liquid without change of temperature.

(ii) State effect of impurities on melting point (01mark)

Impurities lower the melting point.

(b) Explain why there is no change in temperature when a substance is melting (04marks)

Supply of heat to a melting solid reduces the forces of attraction between the molecules and increases the separation between them. This increases the potential energy (P.E) between the molecules while keeping kinetic energy (K.E) of the molecules the same. Further increase in separation between the molecules causes the regular pattern to collapse as the solid changes to liquid. Until this process is complete, the temperature does not change.

(c) With the aid of a labelled diagram, describe the continuous flow method of measuring the specific heat capacity of a liquid. (06marks)

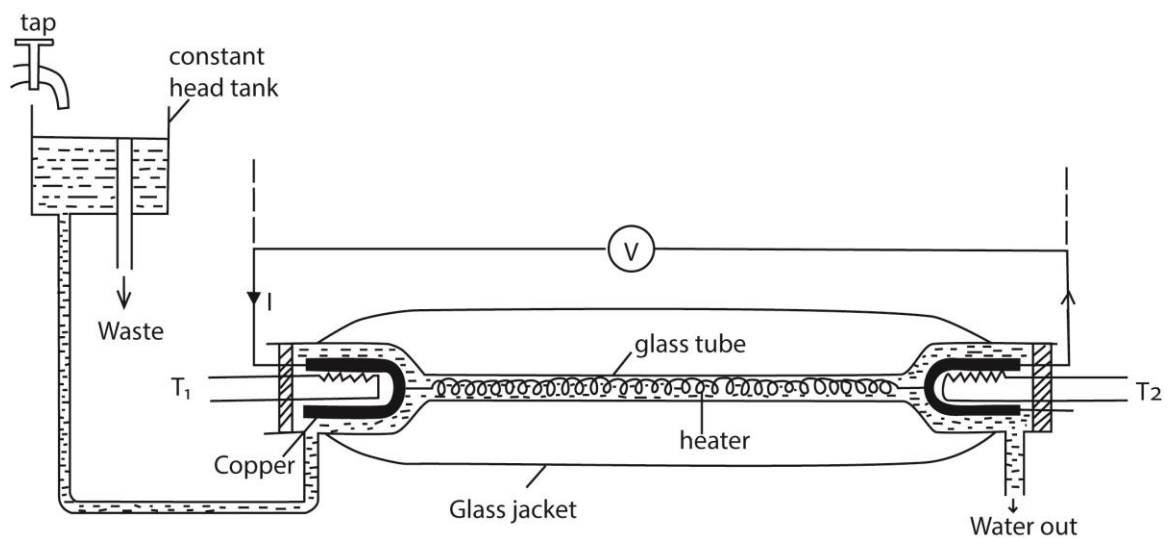

- A liquid is allowed to flow at constant rate

- Power is switched on and the liquid is heated until temperatures registered by T_1 and T_2 are steady and the values θ_1 and θ_2 respectively are recorded.
- The p.d V and current I are recorded from the voltmeter and ammeter respectively
- The mass, m of a liquid collected in time t is recorded
- At steady state; $VIt = mc(\theta_2 - \theta_1) + h$ (i)
where h is heat lost to the surrounding
- The rate of flow is changed and the voltage and current are adjusted until the steady readings of T_1 and T_2 are θ_1 and θ_2 respectively
- If m_1 , V_1 and I_1 are the values mass of liquid collected in time t , voltmeter and ammeter readings respectively, then

$$V_1 I_1 t = m_1 c (\theta_2 - \theta_1) + h \text{ (ii)}$$

Subtracting (ii) from (i)

$$c = \frac{(VI - V_1 I_1)t}{(m - m_1)(\theta - \theta_1)}$$

- (d) In an experiment to determine the specific latent heat of fusion of ice, heating coil is placed in a filter funnel and surrounded by lumps of ice. The following sets of reading were obtained.

V(V)	4.0	6.0
I(A)	2.0	3.0
Mass of water m (g) collected in 500s	14.9	29.8

Calculate

- (i) Specific latent heat of fusion of ice (04marks)

$$\text{Specific latent heat } c_f = \frac{(VI - V_1 I_1)}{(m - m_1)} = \frac{4 \times 2 - 6 \times 3}{\frac{14.9}{500 \times 10^3} - \frac{29.8}{500 \times 10^3}} = 3.36 \times 10^5 \text{ J/kg}$$

- (ii) Energy gained in the course of obtaining the first set of readings (03marks)

$$I_1 V_1 = m_1 c_f + h$$

$$4 \times 2 = \frac{14.9}{500 \times 10^3} \times 3.36 \times 10^5 + h$$

$$h = -2W$$

$$\text{Energy gained from surrounding} = h \times t = 2 \times 500 = 1000J$$

- (e) Why are two sets of reading necessary in (d) above. (01mark)

To account for heat gained from surrounding

20. (a) (i) State Dalton's law of partial pressures. (01marks)

Dalton's law of partial pressures states that the total pressure of a mixture of gases that do not react chemically is equal to the sum of partial pressures

- (ii) Using the expression $p = \frac{1}{3} \rho c^2$, where p is the pressure of a gas of density ρ and mean square speed c^2 , derive Dalton's law of partial pressures for two gases. (05marks)

$$P = \frac{1}{3} N \frac{m}{V} c^2 = \frac{2}{3} N \left(\frac{1}{2} m c^2 \right)$$

$$\text{For gas 1, } P_1 V_1 = \frac{2}{3} N_1 \left(\frac{1}{2} m_1 c_1^2 \right)$$

$$\Rightarrow N_1 = \frac{3}{2} P_1 V_1 \cdot \frac{1}{K_1}$$

Similarly for gas 2

$$N_2 = \frac{3}{2} P_2 V_2 \cdot \frac{1}{K_2}$$

For a mixture of gases, $N = \frac{3}{2} P V \cdot \frac{1}{K}$; but $N = N_1 + N_2$

$$\frac{3}{2} P V \cdot \frac{1}{K} = \frac{3}{2} P_1 V_1 \cdot \frac{1}{K_1} + \frac{3}{2} P_2 V_2 \cdot \frac{1}{K_2}$$

Since temperature is constant, $K_1 = K_2 = K$

$$- \quad P V = P_1 V_1 + P_2 V_2$$

$$- \quad \text{But } V = V_1 = V_2$$

$$- \quad \therefore P = P_1 + P_2$$

(b) (i) What is meant by isothermal process and adiabatic process. (02marks)

Isothermal process is the expansion or compression of a gas at constant temperature.

Adiabatic process is the expansion or compression of a gas where there is no heat loss or gain into the gas.

(ii) Explain why adiabatic expansion of a gas causes cooling (03marks)

During an adiabatic expansion of a gas, no heat is supplied to the gas. Molecules strike the receding piston and bounce off with reduced velocities and hence lower kinetic energy.

Since kinetic energy is proportional to temperature, the gas cools during the expansion

(c) A gas at a temperature of 17°C and pressure $1.0 \times 10^5 \text{Pa}$ compressed isothermally to half its original volume. It is then allowed to expand adiabatically to its original volume

(i) Sketch a P-V curve the above process (02marks)

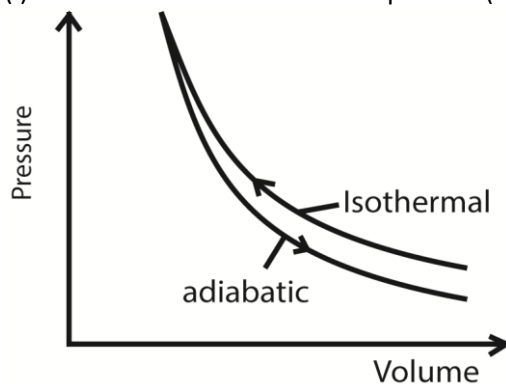

(ii) If the specific heat capacity at constant pressure is $2100 \text{Jmol}^{-1}\text{K}^{-1}$ and at constant volume is $1500 \text{Jmol}^{-1}\text{K}^{-1}$, find the final temperature of the gas (04marks)

$$\gamma = \frac{2100}{1500} = 1.4$$

$$T_2 V_2^{\gamma-1} = T_3 V_3^{\gamma-1}$$

$$290 \left(\frac{V}{2} \right)^{0.4} = T_3 V^{0.4}$$

$$T_3 = 219.8 \text{K}$$

(d) (i) What is meant by saturated vapour? (01mark)

A saturated vapour is a vapour in dynamic equilibrium with its own liquid.

(ii) Explain briefly the effect of altitude on the boiling point of a liquid (02marks)

A liquid boils when its saturated vapour pressure is equal to the external vapour pressure. Atmospheric pressure decreases with increasing altitude, hence the boiling point of a liquid reduces as the altitude increases.

21. (a)(i) Define a black body. (01mark)

A black body is a body which absorbs all the radiations incident on it and does not reflect or transmit any.

(ii) Sketch and explain graphs of intensity versus wavelength for three different temperatures of a black body. (03marks)

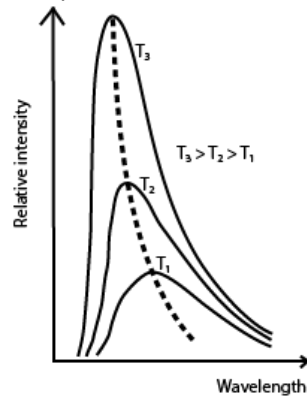

- For every wave length, relative intensity increases as temperature is increased.
- The wavelength at which maximum intensity occur shifts to the shorter wavelength as temperature is increased.
- λ_{\max} is the wavelength of radiation emitted at maximum intensity/emission of a black body at a particular temperature.

(b) Describe with the aid of a diagram how an optical radiation pyrometer is used to measure temperature. (06marks)

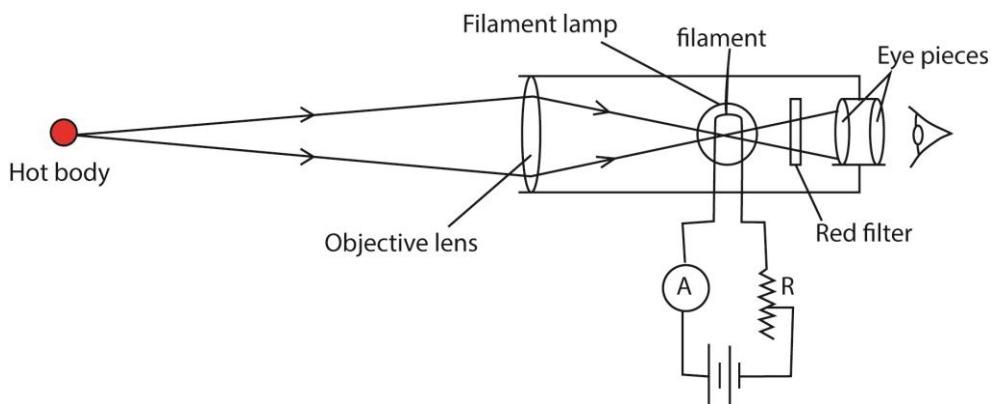

- the filament is focused on the eye piece and the objective focuses the object so that the image of the object lies in the same plane as the filament
- Light from the hot object and the filament is passed through the red filter and viewed by the eyepiece.
- Current is adjusted by the rheostat R until the filament and the object are equally bright.
- The temperature of the hot body is then read from the calibrated ammeter, A.

(c) (i) State Prevost's theory of heat exchanges (01marks)

When a body is in thermal equilibrium with its surrounding, its rate of emission of radiation to surrounding is equal to the rate of absorption of the radiation from the surrounding.

(ii) Metal sphere of radius 1.5cm is suspended within an evacuated enclosure whose walls are at 320K. The emissivity of the metal is 0.40. Find the power input required to maintain the sphere at a temperature of 320K, if heat conduction along the support is negligible. (04marks)

$$P = \epsilon A \sigma (T_4 - T_0^4)$$

$$= 0.4 \times 4\pi (1.5 \times 10^{-2})^2 \times 5.67 \times 10^{-8} (320^4 - 320^4) = 0$$

(d) A metal boiler is 1.5cm thick. Find the difference in temperature between the inner and outer surfaces if 40kg of water evaporate from the boiler per meter squared per hour. [Latent heat of vaporization of water = 2268kJkg⁻¹, Thermal conductivity of the metal of the boiler = 63Wm⁻¹K⁻¹] (05marks)

$$\frac{dQ}{dt} = \frac{40}{3600} \times 2268000 = 22500$$

$$\text{From } \frac{dQ}{dt} = \frac{kA(\theta_2 - \theta_1)}{l}$$

$$22500 = \frac{63 \times 1 \times \Delta Q}{1.5 \times 10^{-2}}$$

$$\Delta Q = 6.0K$$

22. (a) (i) State four desirable properties a material must have to be used as a thermometric substance. (02marks)

- The property must vary linearly with temperature
- The property must vary continuously with temperature
- The property must be easily measurable
- The property must be safe to handle

(ii) State why scales of temperature based on different thermometric properties may not agree. (01mark)

It is because different thermometric properties vary differently with temperature but only agree at the fixed points.

(b) With the aid of diagram explain how a bolometer is used to detect thermal radiation. (06marks)

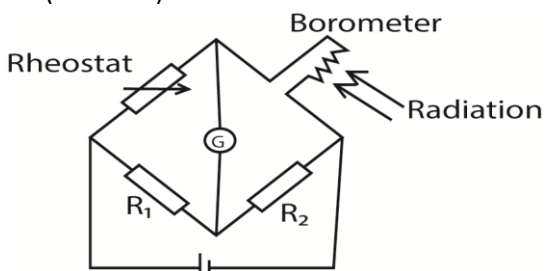

The bolometer strip is connected to Wheatstone bridge circuit above. The rheostat is adjusted until the galvanometer shows no deflection. When the radiations fall on the strip, they are absorbed and its temperature rises leading to an increase in resistance. The galvanometer deflects showing the presence of radiations.

(c) Describe, with the aid of a diagram an experiment to determine specific heat of vaporization of steam using the method of mixtures. (07marks)

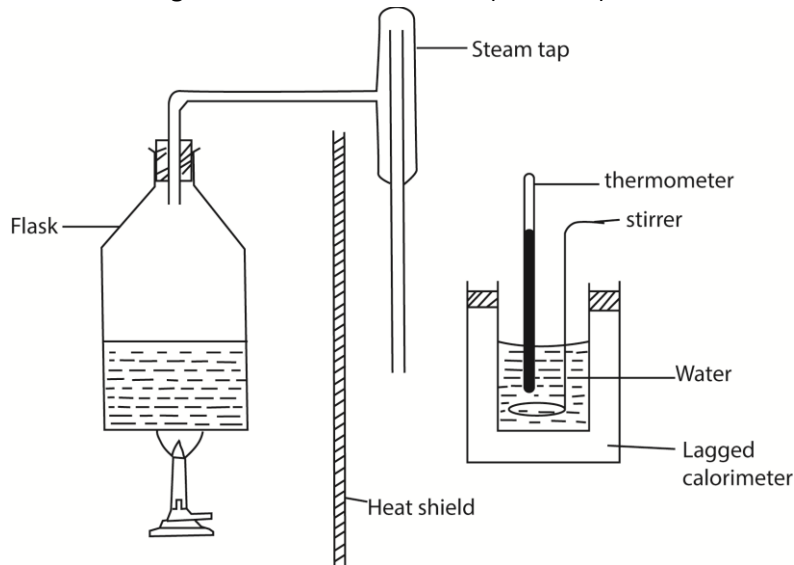

- The initial temperature θ_0 and mass, m of water in the calorimeter are measured
- Steam from boiling water is passed into water in a calorimeter and after a reasonable temperature rise, flow of steam is stopped and final temperature, θ_f is recorded.
- Mass m_2 of water in the calorimeter is then taken
- The mass of steam condensed, $m_s = (m_2 - m)$

Given that the heat capacity of the calorimeter = C

Heat gained by steam = heat gained by water and calorimeter

$$m_s c_v + m_s c(100 - \theta_f) = (m_2 - m)c(\theta_f - \theta_0) + C(\theta_f - \theta_0)$$

c_v = specific latent heat of vaporization

c = specific heat capacity of water

(d) A 600W electricity heater is used to raise the temperature of a certain mass of water in a thermos flask from room temperature to 80°C . The same temperature rise is obtained when steam from a boiler is passed into an equal mass of water at room temperature in the same time. If 16g of water were being evaporated every minute in the boiler, find the specific latent heat of vaporization of steam, assuming no heat losses. (04marks)

Rate of evaporation = 0.016kg per minute

$$= \frac{0.016}{60} \text{ kgs}^{-1}$$

Let L_v be specific latent heat of vaporization

$$P = mL_v + mc\theta$$

$$600 = \frac{0.016}{60} c_v + \frac{0.016}{60} \times 4200 \times (100 - 80)$$

$$L_v = 2.2 \times 10^6 \text{ Jkg}^{-1}$$

23. (a) Define the following

(i) Absolute zero (01marks)

It is the temperature attained when molecules slow down and acquire the least possible energy

(ii) Cooling correction (01marks)

It is the temperature added to experimentally observed maximum temperature to cater for heat lost to the surroundings.

(b) (i) State Dalton's law of partial pressures (01mark)

Dalton's law of partial pressures states that the total pressure of a mixture of gases that do not react chemically is equal to the sum of partial pressures

(ii) Using the expression $p = \frac{1}{3}\rho c^2$, where p is the pressure of a gas of density ρ and mean square speed c^2 , derive Daltons law of partial pressures for two gases. (05marks)

$$P = \frac{1}{3}N \frac{m}{V} c^2 = \frac{2}{3}N \left(\frac{1}{2} m c^2 \right)$$

$$\text{For gas 1, } P_1 V_1 = \frac{2}{3} N_1 \left(\frac{1}{2} m_1 c_1^2 \right)$$

$$\Rightarrow N_1 = \frac{3}{2} P_1 V_1 \cdot \frac{1}{K_1}$$

Similarly for gas 2

$$N_2 = \frac{3}{2} P_2 V_2 \cdot \frac{1}{K_2}$$

For a mixture of gases, $N = \frac{3}{2} P V \cdot \frac{1}{K}$; but $N = N_1 + N_2$

$$\frac{3}{2} P V \cdot \frac{1}{K} = \frac{3}{2} P_1 V_1 \cdot \frac{1}{K_1} + \frac{3}{2} P_2 V_2 \cdot \frac{1}{K_2}$$

Since temperature is constant, $K_1 = K_2 = K$

$$- \quad PV = P_1 V_1 + P_2 V_2$$

$$- \quad \text{But } V = V_1 = V_2$$

$$- \quad \therefore P = P_1 + P_2$$

(c) Explain clearly the steps taken to determine the cooling correction when measuring the specific heat capacity of a poor conductor by the method of mixtures. (07marks)

- Pour a liquid in a calorimeter and place it on a table
- Place a thermometer into the liquid and after sometime, record the temperature of the surroundings, θ_0 .
- Gently place a hot solid into the liquid and stir.
- Record the temperature of the mixture at suitable interval until the temperature of the mixture has fallen by about 1°C below the observed maximum temperature, θ_1 .
- Plot a graph of temperature against time

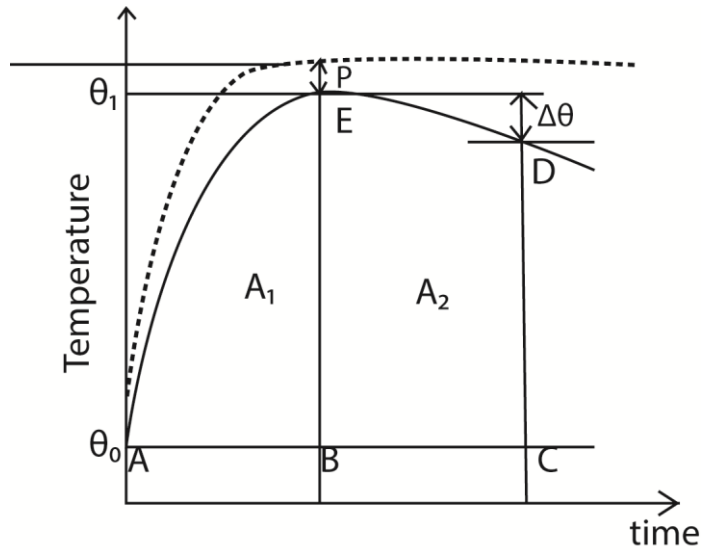

- The broken line shows how we would expect the temperature to rise if no heat were lost and the difference, P, between the plateau of this imaginary curve, and the crest of the experimental curve, E, is known as the 'cooling correction'
 - Draw a line AC through θ_0 parallel to the time axis.
 - Draw a line BE through θ_1 parallel to the temperature axis.
 - Draw a line CD beyond BE parallel to the temperature axis and note $\Delta\theta$
 - Estimate the area A_1 and A_2 under the graph by counting the square on the graph paper
 - Cooling correction, P s given by the graph
- Cooling correction, $P = \frac{A_1}{A_2} \times \Delta\theta^\circ\text{C}$

24. (a) Define thermal conductivity of material and state its units. (02marks)

Thermal conductivity is the rate of heat flow per unit area of cross section area per temperature gradient. Units are $\text{Wm}^{-1}\text{K}^{-1}$

(b) Describe an experiment to determine the thermal conductivity of copper. (06marks)

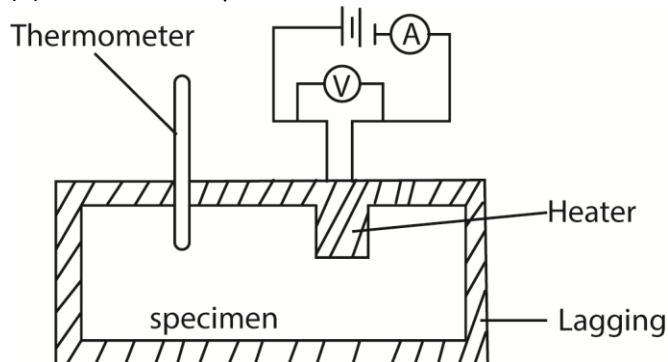

- Two holes are drilled into the specimen solid of copper of mass m.
- A thermometer is inserted in one of the holes and an electric heater into the other hole. The holes are then filled with a good conducting fluid, e.g. oil to ensure thermal contact.
- The apparatus is insulated and initial temperature θ_0 is recorded.
- The heater is switched on at the same time a stop clock is started.

- The steady values of ammeter reading, I and voltmeter reading, V are recorded.
- After considerable temperature rise, the heater is switched off and stop clock stopped.
- The highest temperature θ_1 recorded and time t taken noted.
- The specific heat capacity, c, of the conducting solid is calculated from

$$c = \frac{IVt}{m(\theta_1 - \theta_0)}$$

(c) A double glazed window has two glasses each of thickness 4.0mm separated by a layer of air of thickness 1.5mm. If the two inner air-glass surfaces have steady temperature of 20°C and 4°C respectively. Find the

(i) temperatures of the outer air-glass surfaces (03marks)

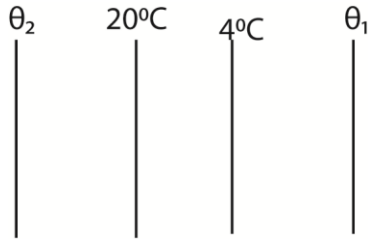

$$\frac{Q}{t} = \frac{0.72A(\theta_2 - 20)}{4 \times 10^{-3}} = \frac{0.025A(20 - 4)}{1.5 \times 10^{-3}} = \frac{0.72A(4 - \theta_1)}{4 \times 10^{-3}}$$

$$\theta_2 = 21.48^\circ\text{C}; \theta_1 = 2.52^\circ\text{C}$$

(ii) the amount of heat that flows across an area of the window of 2m² in 2hours.

$$\frac{Q}{t} = \frac{0.025 \times 16 \times 2}{1.5 \times 10^{-3}} = 533.3\text{Js}^{-1}$$

$$\text{Heat flow in two hours} = 533.3 \times 2 \times 3600 = 3.84 \times 10^6\text{J}$$

[Conductivity of glass = 0.72Wm⁻¹k⁻¹ and that of air = 0.025Wm⁻¹k⁻¹]

(d)(i) What is a black body? (01mark)

A black body is one that absorbs all incident radiation falling on it and transmits or reflects none.

(ii) Explain how a welder can protect the eyes from damage. (03marks)

A welder puts on dark shades that absorb ultraviolet light which damages the eyes.

(iii) Calculate the wavelength of the radiation emitted by a black body at 6000K

[Wien's displacement constant = 2.9 x 10⁻³mK] (02marks)

$$\lambda T = 2.9 \times 10^{-3}$$

$$6000\lambda = 2.9 \times 10^{-3}$$

$$\lambda = 4.8 \times 10^{-7}\text{m}$$

25. (a) (i) State two differences between saturated and unsaturated vapours. (02marks)

- A saturated vapour pressure is one which is in dynamic equilibrium with its own liquid and an unsaturated vapour is one that is not in dynamic equilibrium with its own liquid.
- A saturated vapour pressure does not obey gas laws whereas unsaturated vapour approximately obey gas laws.

(ii) Sketch graphs of pressure against temperature for an ideal gas and for saturated water vapour originally at 0°C (03marks)

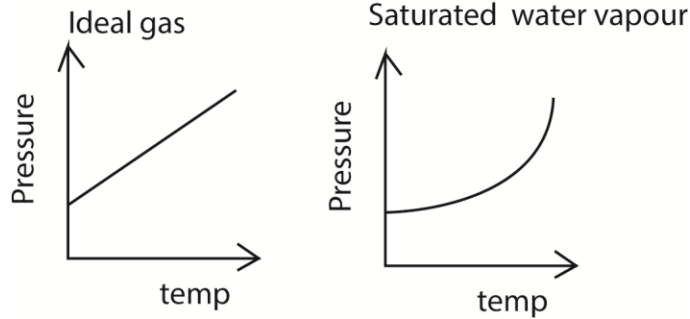

(b) The specific heat capacity of oxygen at constant volume is $719 \text{Jkg}^{-1}\text{K}^{-1}$ and its density at standard temperature and pressure is 1.429kgm^{-3} . Calculate the specific heat capacity of oxygen at constant pressure (04marks)

$$PV = nrT$$

$$r = \frac{P}{T} \left(\frac{V}{m} \right) = \frac{1.01 \times 10^5}{273 \times 1.429} = 258.9 \text{Jkg}^{-1}\text{K}^{-1}$$

$$c_p - c_v = r$$

$$c_p = 719 + 258.9 = 977.9 \text{Jkg}^{-1}\text{K}^{-1}$$

(c) (i) With the aid of a labelled diagram, describe an experiment to determine standard saturated vapour pressure of water. (05marks)

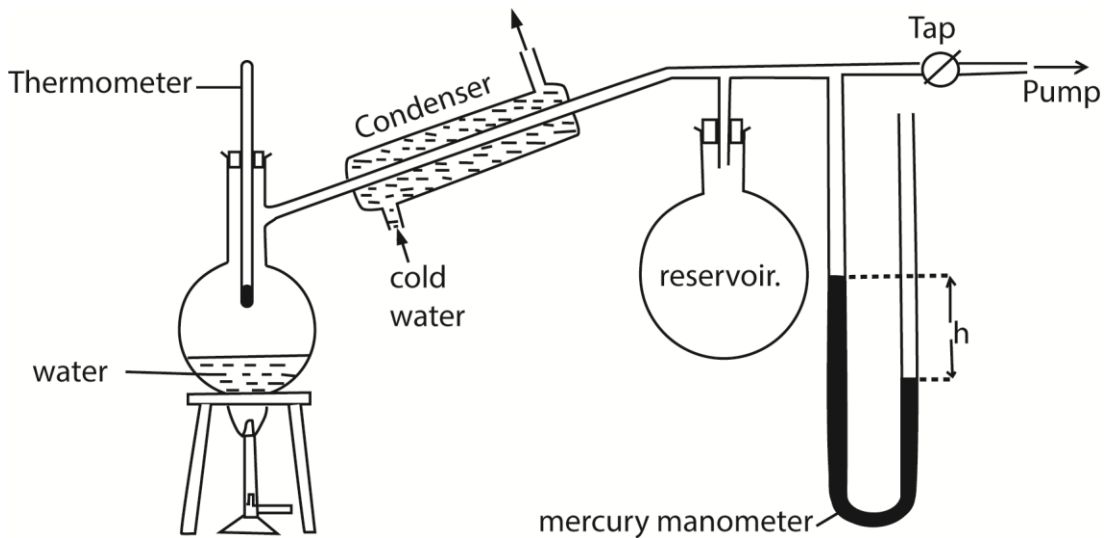

- The pressure of the air in R is shown by the mercury manometer; if its height is h , the pressure in mm mercury is $P = H-h$, where H is the barometer height.
- The tap is opened and the pressure above water varied using the pump to a suitable value.
- The tap is closed and water in the flask is heated until it boils.
- The temperature θ and difference in mercury levels, h , are noted and recorded.
- The saturated vapour pressure, $P = (H \pm h)$ is calculated
- The procedure is repeated for other values of θ and h

- A graph of P versus θ is plotted and the saturated vapour pressure at a particular temperature is obtained.

(ii) State how the experiment set up in (c) (i) may be modified to determine a saturated vapour pressure of above atmospheric pressure (01marks)

By replacing the vacuum pump with a bicycle pump

(d)(i) Define ideal gas (01mark)

An Ideal gas is one that obeys Boyle's law under all conditions

(ii) State and explain the conditions under which real gases behave as ideal gases. (04marks)

- At higher temperature, the intermolecular spacing increases and intermolecular forces become negligible
- At very low pressure, the gas occupies negligible volume of the container.

26. (a) (i) What is a black body?(01marks)

A black body is one which absorbs all the radiation that falls upon it, and reflects or transmits none.

(ii) Explain with the aid of a diagram how black body can be approximated. (03marks)

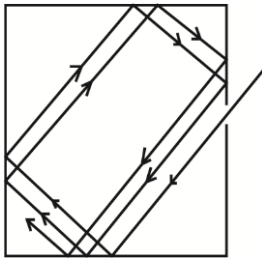

When radiation enters a black container through a hole, it undergoes multiple reflections. At each reflection, part of the radiation is absorbed. After several reflections, all the radiation is retained inside the container. Hence it approximates to a black body.

(iii) With the aid of sketch graphs explain the salient features of the spectral distribution of black body radiation (04 marks)

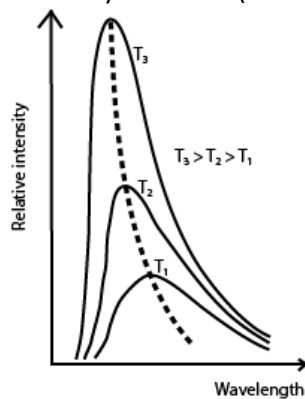

- For every wave length, relative intensity increases as temperature is increased.
- The wavelength at which maximum intensity occur shifts to the shorter wavelength as temperature is increased.

- λ_{\max} is the wavelength of radiation emitted at maximum intensity/emission of a black body at a particular temperature.

(b) Give four properties of ultraviolet radiation. (02marks)

- produce ionization and fluorescence
- affect photographic plates
- produces photoelectric effect
- promotes chemical reaction
- can be reflected and refracted.

(c) Describe an experiment to compare the energy radiated by two surfaces at different temperatures (04marks)

- A metal cube whose sides have a variety of finishes; dull black, white, highly polished is filled with water and this water is kept boiling by a constant heat supply.
- A thermopile is made to face the various finishes of the cube at equal distances and each time the deflection on the galvanometer is noted.
- The deflection of the galvanometer is greatest when the thermopile is facing the dull-black surface and least when facing the highly polished surface.
- This implies that the dull-black surface is a better radiator.

(d) (i) State Stefan's law. (01mark)

Stefan's law states that the total power radiated by a black body per unit surface area is proportional to the fourth power of its absolute temperature. i.e. $\frac{P}{A} \propto T^4$

(ii) The earth receives energy from the sun at the rate of $1.4 \times 10^3 \text{ Wm}^{-2}$. If the ratio of the earth's orbit to the sun's radius is 216, calculate the surface temperature of the sun. (05marks)

$$\text{Power radiated by the sun} = 4\pi r^2 \sigma T^4$$

$$\text{Energy intensity} = \frac{4\pi r^2 \sigma T^4}{4\pi R^2}$$

$$\therefore \frac{4\pi r^2 \sigma T^4}{4\pi R^2} = 1.4 \times 10^3$$

$$T^4 = \frac{1.4 \times 10^3}{5.7 \times 10^{-8}} \left(\frac{R}{r}\right)^2 = \frac{1.4 \times 10^3}{5.7 \times 10^{-8}} \times 216^2$$

$$T = 5.82 \times 10^3 \text{ K}$$

27. (a) Define specific latent heat of vaporization. (01mark)

Specific latent heat of vaporization is the amount of heat required to change 1kg mass of a liquid into vapour at constant temperature.

(b) With the aid of labelled diagram, describe an experiment to measure the specific latent heat of vaporization of a liquid using an electrical method. (07marks)

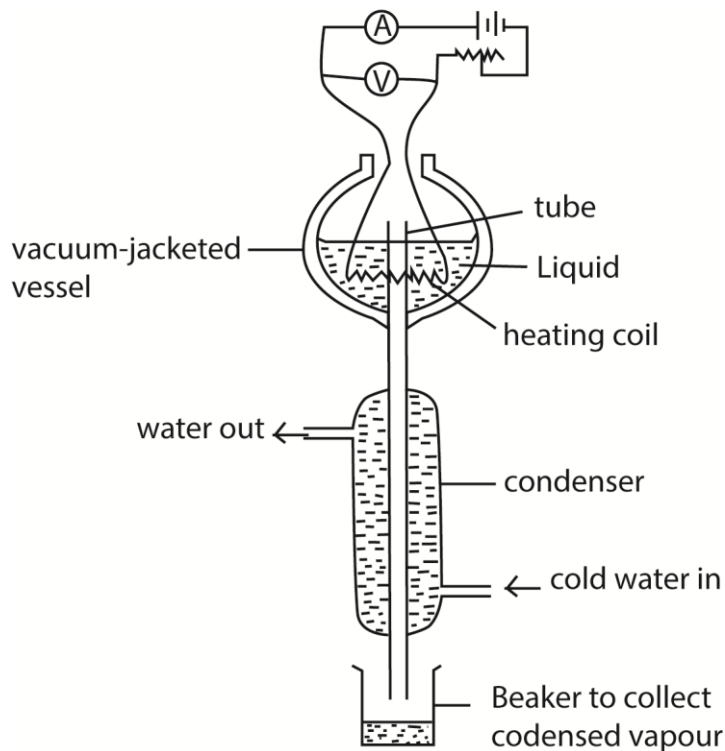

- Put the liquid whose specific latent heat of vaporization is required in a vacuum jacketed vessel as shown above.
- The liquid is heated to boiling point.
- The current, I , and voltage, V are recorded.
- The mass of liquid, m , condensed in time, t , is determined.
- Then $IV = \frac{m}{t}L + h$, where h is the rate of heat loss to the surroundings
- To eliminate, h , the experiment is repeated for different values of I' and V' and the mass of the liquid, m' condensed in time t is determined.
- Again $I'V' = \frac{m'}{t}L + h$

$$\text{Latent heat of vaporization, } L = \frac{(I'V' - IV)t}{(m' - m)}$$

(c) Explain the effect of pressure on the boiling point of a liquid. (02marks)

- Since a liquid boils when its saturated vapour pressure is equal to external pressure.
- Increasing the external pressure increases the boiling point of a liquid because the liquid has to be heated to a higher temperature to make its saturated vapour pressure equal to external pressure

(d) A liquid of specific heat capacity $2.8 \times 10^3 \text{ Jkg}^{-1}\text{K}^{-1}$ and specific latent heat of vaporization $9.00 \times 10^5 \text{ Jkg}^{-1}$ is contained in a flask of heat capacity 800 JK^{-1} at a temperature of 32°C . An electric heater rated 1 kW is immersed in 2.5 kg of the liquid and switched on for 12 minutes, calculate the amount of liquid that boiled off, given that the boiling point of the liquid is 80°C . (06marks)

Heat supplied by the heater = $mc\theta + C\theta + m_1L$

$$1000 \times 12 \times 60 = 2.5 \times 2.8 \times 10^3(80-32) + 800 \times (80-32) + 9.00 \times 10^5 m_1$$

Mass of the liquid evaporates, $m_1 = 0.384\text{kg}$

- (e) (i) Two thermometers are used to measure the temperature of a body. Explain why the temperatures may be different. (02marks)

Because thermometric properties vary differently with temperature and only agree at fixed points.

- (ii) A platinum resistance thermometer has a resistance of 5.42Ω at the triple point of water. Calculate the resistance at a temperature of 50.0°C . (02marks)

$$T = \frac{R_T}{R_{tr}} \times 273.16$$

$$(273 + 50) = \frac{R_{50}}{5.42} \times 273.16$$

$$R_{50} = 6.41\Omega$$

28. (a) Define

- (i) Specific heat capacity (01mark)
Specific heat capacity is the amount of heat required to rise the temperature of 1kg mass of a substance by 1K.
- (ii) Specific latent heat of vaporization of a liquid. (01 mark)
Specific latent heat of vaporization is amount of heat required to convert 1kg of a liquid substance at its boiling point into vapor at constant temperature.

(b) With the aid of a labelled diagram, describe the electrical method of determining the specific heat capacity of a solid (07marks)

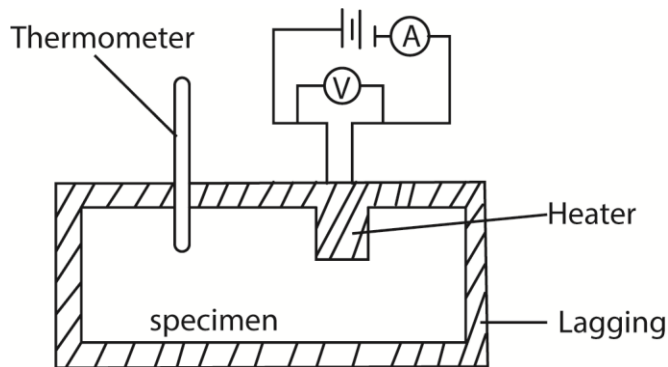

- Two holes are drilled into the specimen solid of mass m .
- A thermometer is inserted in one of the holes and an electric heater into the other hole. The holes are then filled with a good conducting fluid, e.g. oil to ensure thermal contact.
- The apparatus is insulated and initial temperature θ_0 is recorded.
- The heater is switched on at the same time a stop clock is started.
- The steady values of ammeter reading, I and voltmeter reading, V are recorded.
- After considerable temperature rise, the heater is switched off and stop clock stopped.
- The highest temperature θ_1 recorded and time t taken noted.
- The specific heat capacity, c , of the conducting solid is calculated from

$$c = \frac{IVt}{m(\theta_1 - \theta_0)}$$

- (c) An electrical heater rated 48W, 12V is placed in a well-insulated metal of mass 1.0kg at a temperatures of 18°C. When power is switched on for 5minutes, the temperature of the metal rises to 34°C. Find the specific heat capacity of the metal (04marks)

Heat supplied by the heater, $IVt = mc\theta$

$$48 \times 5 \times 60 = 1 \times c \times (34-18)$$

$$\text{Specific heat capacity, } c = 900 \text{Jkg}^{-1}\text{K}^{-1}$$

- (d) (i) State Newton's law of cooling (01marks)

The rate of loss of heat is proportional to the excess temperature over the surroundings under conditions of forced convection.

(ii) Use Newton's law of cooling to show that $\frac{d\theta}{dt} = -k(\theta - \theta_R)$

Where $\frac{d\theta}{dt}$ is the rate of fall of temperature and θ_R is the temperature of the surrounding.

From the above law, $\frac{dQ}{dt} \propto (\theta - \theta_R)$

$$\Rightarrow \frac{dQ}{dt} = k(\theta - \theta_R)$$

But $\frac{dQ}{dt} = mc \frac{d\theta}{dt}$

$$\Rightarrow \frac{d\theta}{dt} = k(\theta - \theta_R)$$

Since for a given body, m and c are constant.

- (e) Explain why evaporation causes cooling. (03marks)

During evaporation the most energetic molecules at the liquid surface escape leaving molecules with low kinetic energy. Since mean kinetic energy of molecules is directly proportional to absolute temperature, the liquid cools.

29. (a) The pressure, P, of an ideal gas is given by $P = \frac{1}{3} \rho c^2$, where ρ is the density of the gas and c^2 its mean square speed.

- (i) Show clearly the steps taken to derive this expression (06marks)

Consider a molecule of mass, m, moving in a cube of length, l and velocity, u.

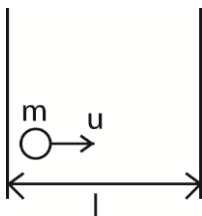

Change in momentum = $mu - (-mu) = 2mu$

Rate of change of momentum = $\frac{2mu}{t}$

Time, t , between collision = $\frac{2l}{u}$

$$F_1 = 2mu \div \frac{2l}{u} = \frac{mu^2}{l}$$

For N molecules, force on the wall,

$$F = \frac{mu_1^2}{l} + \frac{mu_2^2}{l} + \frac{mu_3^2}{l} + \dots + \frac{mu_N^2}{l}$$

Pressure, $P = \frac{F}{A} = \frac{m}{l^3} (u_1^2 + u_2^2 + u_3^2 + \dots + u_N^2)$ since $A = l^2$

$$u^2 = \frac{u_1^2 + u_2^2 + u_3^2 + \dots + u_N^2}{N}$$

$$Nu^2 = u_1^2 + u_2^2 + u_3^2 + \dots + u_N^2$$

$$\therefore P = \frac{Nmu^2}{l^3} = \rho u^2; \text{ since } \rho = \frac{Nm}{l^3}$$

$$c^2 = u^2 + v^2 + w^2 \text{ and } u^2 = v^2 + w^2$$

$$\therefore c^2 = 3u^2 \Rightarrow u^2 = \frac{1}{3}c^2$$

$$\therefore P = \frac{1}{3}\rho c^2$$

(ii) State the assumptions made in deriving this expression (02marks)

- Intermolecular forces of attraction are negligible
- The volume of the gas molecules are negligible compared to that of the container
- Molecules make perfectly elastic collision
- The duration of collision is negligible compared to the time between collisions

(b) Sketch the pressure versus volume curve for a real gas for temperatures above and below the critical temperature. (03marks)

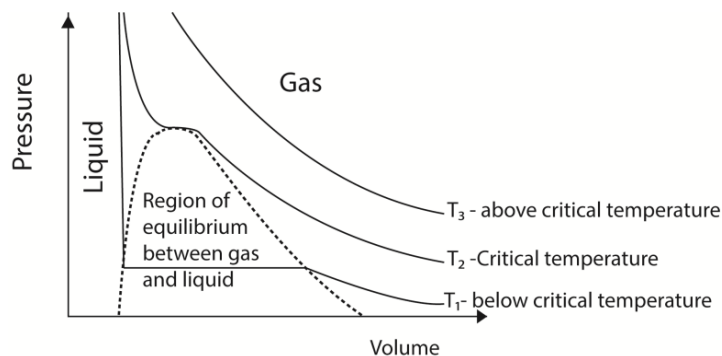

- Above the critical temperature a gas obeys Boyle's law.

- Below the critical temperature a gas exist as unsaturated vapour at low pressure when the pressure is increase it condenses until all the gas is turned into a liquid.

(c) For 1 mole of a real gas, the equation of state is $\left(P + \frac{a}{V^2}\right)(V - b) = RT$

Explain the significance of the terms $\frac{a}{V^2}$ and b. (02marks)

$\frac{a}{V^2}$ - corrects deficit in pressure due to intermolecular attractions of gas molecules

b – accounts for the finite volume of molecules themselves.

(d) A balloon of volume $5.5 \times 10^{-2} \text{m}^3$ is filled with helium to a pressure of $1.10 \times 10^5 \text{Nm}^{-2}$ at a temperature of 20°C . Calculate the

(i) the number of helium atoms in the balloon (03marks)

From $PV = nRT$

$$n = \frac{1.10 \times 10^5 \times 5.5 \times 10^{-2}}{8.31 \times 293} = 2.48 \text{ moles}$$

$$\text{Number of atoms} = 2.48 \times 6.02 \times 10^{23} = 1.49 \times 10^{24}$$

(ii) net force acting on the square meter of material of the balloon if the atmospheric temperature is $1.01 \times 10^5 \text{Nm}^{-2}$ (04marks)

$$F = PA$$

Net force = internal force in the bulb – external force on the bulb

$$= (1.10 \times 10^5 - 1.01 \times 10^5) \times 1.0 = 9.0 \times 10^3 \text{N}$$

30. (a) (i) Define thermal conductivity of a material (01mark)

Thermal conductivity is the rate of heat flow through a material per unit cross sectional area per unit temperature gradient.

(ii) Describe an experiment to determine the thermal conductivity of copper. (06marks)

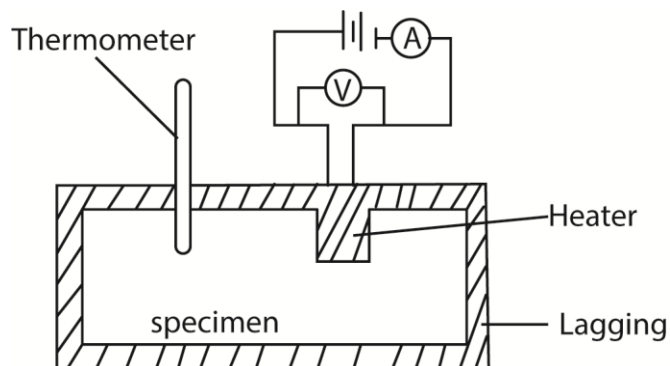

- Two holes are drilled into the specimen solid of copper of mass m.
- A thermometer is inserted in one of the holes and an electric heater into the other hole. The holes are then filled with a good conducting fluid, e.g. oil to ensure thermal contact.

- The apparatus is insulated and initial temperature θ_0 is recorded.
- The heater is switched on at the same time a stop clock is started.
- The steady values of ammeter reading, I and voltmeter reading, V are recorded.
- After considerable temperature rise, the heater is switched off and stop clock stopped.
- The highest temperature θ_1 recorded and time t taken noted.
- The specific heat capacity, c , of the conducting solid is calculated from

$$c = \frac{IVt}{m(\theta_1 - \theta_0)}$$

(b) (i) What is a black body? (01 marks)

A black body is one which absorbs all the radiation of every wavelength falling on it, reflects and transmits none.

(ii) Describe how infrared radiation can be detected using a bolometer. (03marks)

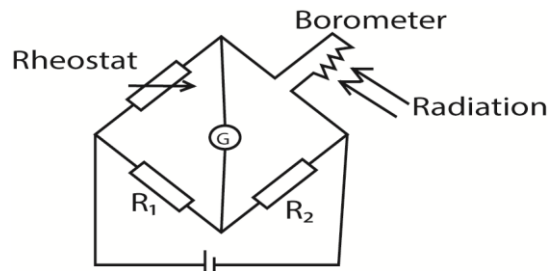

The bolometer strip is connected to Wheatstone bridge circuit above. The rheostat is adjusted until the galvanometer shows no deflection. When the radiations fall on the strip, they are absorbed and its temperature rises leading to an increase in resistance. The galvanometer deflects showing the presence of radiations.

(iii) Give one characteristic property of infrared radiation. (01mark)
Causes sensation of warmth (increases body temperature).

(c) (i) A spherical black body of radius 2.0cm at -73°C is suspended in an evacuated enclosure whose walls are maintained at 27°C . If the rate of exchange of thermal energy is equal to 1.85Js^{-1} , find the value of Stefan's constant, (05marks)

$$T_1 = 27 + 273 = 300\text{K}$$

$$T_2 = -73 + 273 = 200\text{K}$$

$$P = A\sigma(T_1^4 - T_2^4)$$

$$1.85 = 4\pi(0.02)^2\sigma(300^4 - 200^4)$$

$$\sigma = 5.66 \times 10^{-8}\text{Wm}^{-2}\text{K}^{-4}$$

(ii) Calculate the wavelength at which the radiation emitted by the enclosure has maximum intensity (03mark)

$$\lambda_{max}T = 2.9 \times 10^{-3}$$

$$\lambda_{max} = \frac{2.9 \times 10^{-3}}{300} = 9.7 \times 10^{-6}\text{m}$$

31. (a)(i) Define the terms specific heat capacity and specific latent heat of fusion (02marks)

Specific heat capacity is the amount of heat required to raise the temperature of 1kg mass of a substance by 1K of 1°C.

Specific latent heat of fusion is the amount of heat required to change 1kg of solid substance to a liquid at constant temperature.

(ii) Explain the changes that take place in the molecular structure of substances during fusion and evaporation (04marks)

Heat supplied during fusion breaks down the forces that keep ordered pattern of molecules in solid crystalline structure to form a liquid. The potential energy of the molecules increases but the average kinetic energy and temperature of the molecules remain unchanged.

Heat supplied during evaporation breaks molecular bonds in liquids and allows gas molecules to expand against atmospheric pressure which allows them to move independently.

(b) With the aid of a labelled diagram describe an experiment to determine the specific heat capacity of a liquid using the continuous flow method. (08marks)

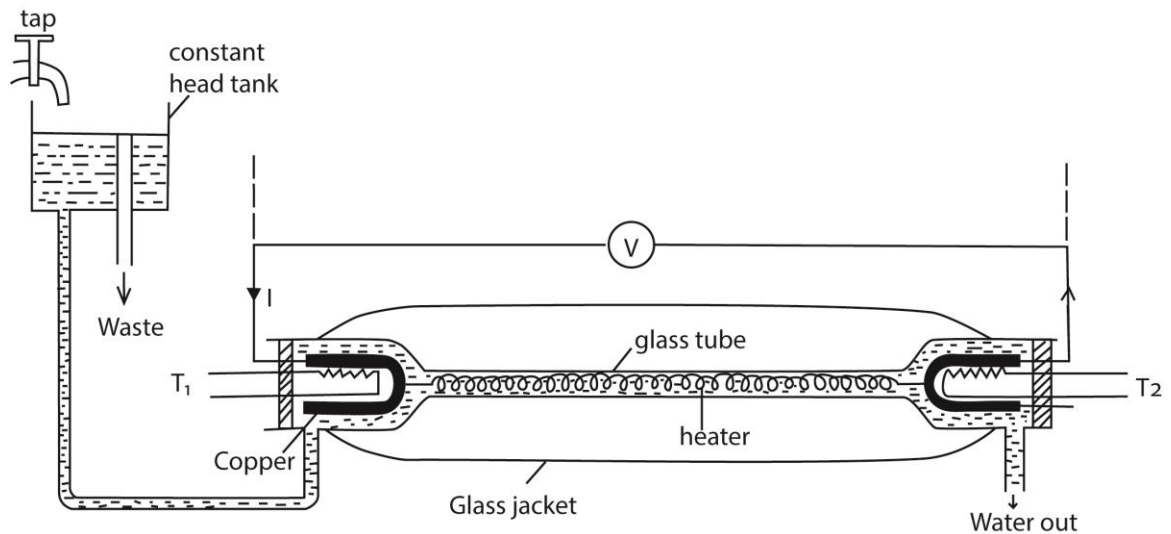

- A liquid is allowed to flow at constant rate
- Power is switched on and the liquid is heated until temperatures registered by T_1 and T_2 are steady and the values θ_1 and θ_2 respectively are recorded.
- The p.d V and current I are recorded from the voltmeter and ammeter respectively
- The mass, m of a liquid collected in time t is recorded
- At steady state; $VIt = mc(\theta_2 - \theta_1) + h$ (i)
where h is heat lost to the surrounding
- The rate of flow is changed and the voltage and current are adjusted until the steady readings of T_1 and T_2 are θ_1 and θ_2 respectively

- If m_1 , V_1 and I_1 are the values mass of liquid collected in time t , voltmeter and ammeter readings respectively, then

$$V_1 I_1 t = m_1 c (\theta_2 - \theta_1) + h \dots\dots\dots (ii)$$

Subtracting (ii) from (i)

$$c = \frac{(VI - V_1 I_1)t}{(m - m_1)(\theta - \theta_1)}$$

(c) Steam at 100°C is passed into a copper calorimeter of mass 150g containing 340g of water at 15°C . This is done until the temperature of the calorimeter and its content is 71°C . If the mass of the calorimeter and its content is found to be 525g, calculate the specific latent heat of vaporization of water. (06marks)

Mass of condensed steam = $525 - (340 + 150) = 35\text{g}$

Heat lost by steam = heat gained water and calorimeter

$$Ml_v + mc\Delta\theta = m_1c\Delta\theta + C\Delta\theta$$

$$0.035l = 0.340(100 - 71) + 0.150 (100 - 71)$$

Specific latent heat capacity, $l_v = 2.259 \times 10^6 \text{Jkg}^{-1}$.

32. (a) (i) Define saturated vapour pressure. (01mark)

Saturated vapour pressure of a liquid is the pressure exerted by vapour in dynamic equilibrium with its liquid

(ii) Describe with the aid of a diagram, how saturated vapour pressure of a liquid can be determined at a given temperature. (06marks)

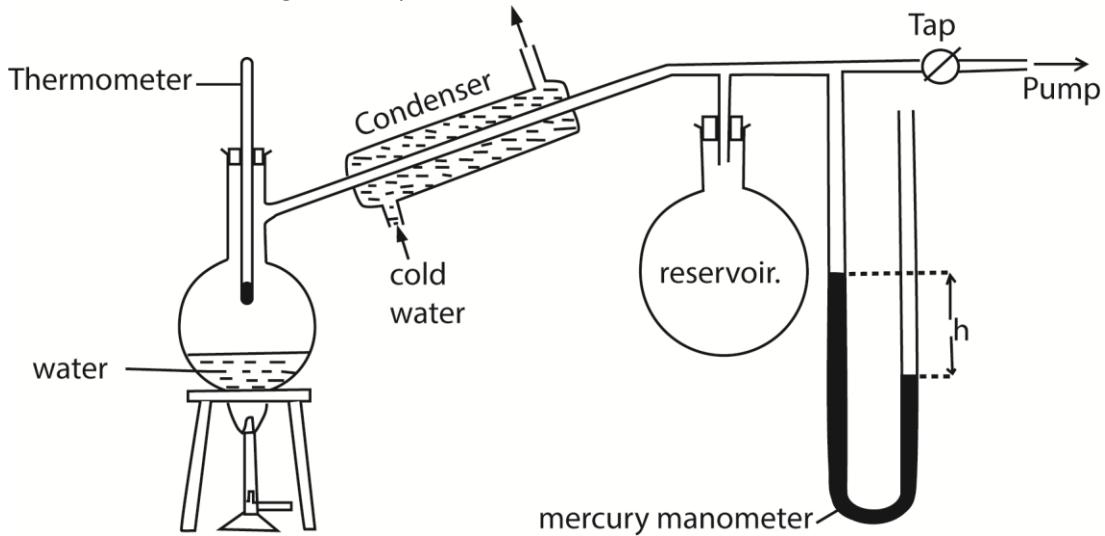

- The pressure of the air in R is shown by the mercury manometer; if its height is h , the pressure in mm mercury is $P = H - h$, where H is the barometer height.
- The tap is opened and the pressure above water varied using the pump to a suitable value.
- The tap is closed and water in the flask is heated until it boils.
- The temperature θ and difference in mercury levels, h , are noted and recorded.

- The saturated vapour pressure, $P = (H \pm h)$ is calculated
- The procedure is repeated other values of θ and h
- A graph of P versus θ is plotted and the saturated vapour pressure at a particular temperature is obtained.

(b) Use the kinetic theory to explain the following observations

(i) Saturated vapour pressure of a liquid increases with temperature. (03marks)

If a liquid is in dynamic equilibrium with its vapour, an increase in temperature increases mean kinetic energy of the molecules and hence the rate at which molecules escape from the liquid.

The density of the vapour increases implying increase in the rate of condensation until dynamic equilibrium is restored. There are now more molecules in the vapour phase than previously that are moving faster and hence higher pressure.

(ii) Saturated vapour pressure is not affected by decrease in volume at constant pressure. (03marks)

A decrease in volume leads to a momentary increase in vapour density. Consequently, the rate of condensation increases while the rate of evaporation rate is constant. When the vapour density reduces, the condensation rate also reduces. So the dynamic equilibrium is restored to the initial value.

(c) When hydrogen gas is collected over water, the pressure in the tube at 15°C and 75°C are 65.5cm and 105.6cm of mercury respectively. If the saturated vapour pressure at 15°C is 1.42cm of mercury, find its value at 75°C (04marks)

$$P_1 = 65.5 - 1.42 = 62.08 \text{ and } T_1 = 273 + 15 = 288\text{K}$$

$$P_2 = 105.6 - P, \text{ and } T_2 = 273 + 75 = 348\text{K}$$

$$\text{From } \frac{P_1}{T_1} = \frac{P_2}{T_2}$$

$$P_2 = \left(\frac{P_1}{T_1}\right) T_2 = 105.6 - \frac{64.08}{288} \times 348 = 28.12\text{cmHg}$$

(d) Explain why the molar heat capacity of an ideal gas at constant pressure differs from the molar heat capacity at constant volume (03marks)

At constant volume, all the heat supplied goes to raising temperature (increasing internal energy of the gas) while at constant pressure, heat is used to raise the temperature of the gas (internal energy) and do external work in expansion to keep the pressure constant.

Therefore the molar heat capacity at constant pressure is more than the molar heat capacity at constant volume.

33. (a) (i) Define thermal conductivity. (01mark)

Thermal conductivity is the rate of heat transfer per unit cross section area per unit temperature gradient.

(ii) Compare the mechanism of heat transfer in poor conductor and good conductor. (05marks)

When one end of a poor conductor is heated, the atoms at the hot end vibrate with increased amplitude, collide with neighboring atoms and lose energy to them. The neighboring atoms also vibrate with increased amplitude, collide with adjacent atoms and lose energy to them. In this way, heat is transferred from one end to another.

Good conductors contain free electron. When heated, the electrons at hot end gain more energy and transfer the energy as they collide with atoms in solid lattice. Also, when one end of a good conductor is heated, the atoms at the hot end vibrate with increased amplitude, collide with neighboring atoms and lose energy to them. The neighboring atoms also vibrate with increased amplitude, collide with adjacent atoms and lose energy to them. In this way, heat is transferred from one end to another.

(b) Describe, with the aid of a diagram how you would measure the thermal conductivity of a poor conductor, stating the necessary precautions (08marks)

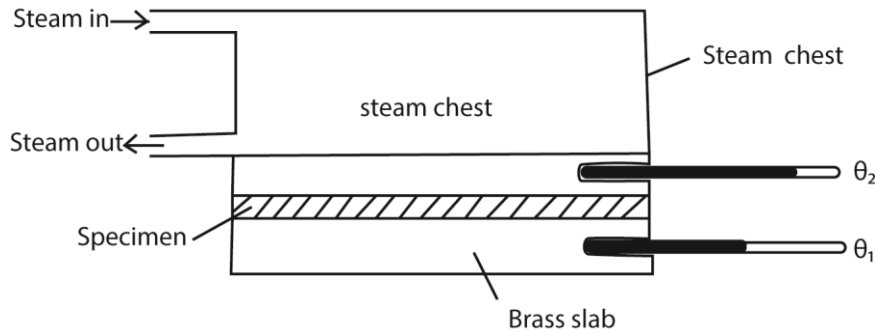

- Glass is cut in form of a thin disc of cross section area, A and thickness, x .
- The disc is sandwiched between a steam chest and brass slab of mass, m and specific heat capacity, c .
- Steam is passed through the chest until the thermometers register steady temperatures, θ_1 and θ_2 .
- Then, $\frac{\theta}{t} = kA \left(\frac{\theta_2 - \theta_1}{x} \right)$
- The glass disc is removed and brass slab is heated directly by steam chest, until its temperature is about 10°C above θ_1 .
- Steam chest is removed and the top of the glass slab is covered by the glass disc.
- The temperature of the slab is recorded at suitable time interval until its temperature is about 10°C below θ_1 .
- A graph of temperature against time is plotted and its slope s determined at θ_1

$$\frac{\theta}{t} = mcs$$

$$\therefore kA \left(\frac{\theta_2 - \theta_1}{x} \right) = mcs$$

$$k = \frac{mcsx}{A(\theta_2 - \theta_1)} \text{ but } A = \frac{\pi D^2}{4}$$

$$\therefore k = \frac{4mcsx}{\pi D^2(\theta_2 - \theta_1)}$$

Precautions

- Sample in a thin disc
- Faces of the disc highly polished to ensure tight uniform contacts

- A thin layer of grease is smeared on faces for good thermal contact.

(c) A cylindrical iron vessel with a base of diameter 15cm and thickness 0.30cm has its base coated with a thin film of soot of thickness 0.10cm. It is then filled with water at 100°C and placed on a large block of ice at 0°C. Calculate the initial rate at which the ice will melt (06marks) (thermal conductivity of soot=0.12Wm⁻¹K⁻¹)

$$\frac{Q}{t} = kA \left(\frac{\theta_2 - \theta_1}{x} \right) = k_1 A \left(\frac{\theta_2 - \theta_1}{x} \right) = ml_f \text{ where } m \text{ is mass that melt per second and } l_f = \text{latent heat of fusion}$$

Thermal conductivity of iron, $k = 75 \text{Wm}^{-1}\text{K}^{-1}$. A in the equation cancel

$$= 75A \left(\frac{100 - \theta_1}{0.3 \times 10^{-2}} \right) = 0.12A \left(\frac{\theta_1 - 0}{0.1 \times 10^{-2}} \right)$$

$$\theta_1 = 99.52^\circ\text{C}$$

$$\text{Also, } kA \left(\frac{\theta_2 - \theta_1}{x} \right) = ml_f$$

$$75 \times \pi \times \frac{(0.15)^2}{4} \left(\frac{100 - 99.52}{0.3 \times 10^{-2}} \right) = m \times 3.3 \times 10^5$$

$$m = 6.42 \times 10^{-4} \text{kg s}^{-1}$$

34. (a)(i) State Boyles law (01mark)

Boyles law states that for a fixed mass of a gas at constant temperature, pressure is inversely proportional to volume.

(ii) Describe an experiment to verify Boyles' law (06mark)

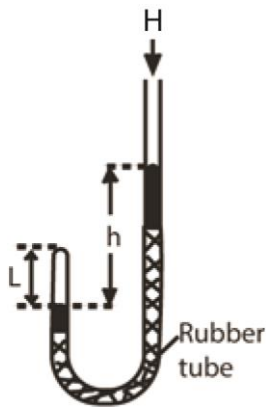

- air in the closed limb of a U-tube barometer as shown above
- mercury is poured to a height, h , and the length of the air column, L is noted.
- the length h is varied to obtain different sets of values of h and L
- Pressure of the gas is calculated from $P = (H + h)\rho g$ where H = height of barometer corresponding to atmospheric pressure, ρ = density of mercury, g = acceleration due to gravity. Note that h can be positive or negative.
- If A is the cross section area, $V = AL$
- Values of h , L , P , V and $1/V$ are tabulated
- A plot of P against $1/V$ gives a straight line through the origin which verifies Boyle's law.

- (iii) Explain why the pressure of a fixed mass of a gas rises if its temperature is increased. (02marks)

When the temperature of a fixed mass of a gas is increased, at constant volume, the velocities and kinetic energy of molecules is increased. They bombard the walls of the container more frequently with increased force. This increases pressure since pressure is proportional to force.

- (b) (i) Define the term thermometric property and give four examples (03marks)

Thermometric property is a physical property whose value varies uniformly and continuously with change in temperature.

Examples

- Volume of constant mass of a gas at constant pressure
- Pressure of a gas at constant volume
- Electrical resistance of a platinum wire
- e.m.f of a thermocouple
-

- (ii) State two qualities of a good thermometric property. (01mark)

- Should vary linearly and continuously with temperature
- Should be sensitive to temperature change
- Should vary over a wide range of temperature.

- (c) (i) With reference to a liquid in glass thermometer, describe the step involved in setting up a Kelvin scale of temperature (03marks)

Length l_{tr} of a liquid column is measured at the triple point of water

Length l_T of liquid column is measured at unknown temperature, T

$$T = \frac{l_T}{l_{tr}} \times 273.16K$$

- (ii) State one advantage and one disadvantage of the resistance thermometer. (01mark)

Advantage

- measures a wide range of temperatures
- very accurate

Disadvantage

- unsuitable for rapidly changing temperatures
- Cannot measure temperature at a point
- Does not give direct readings

- (d) A resistance thermometer has resistance of 21.42Ω at the ice point, 29.10Ω at steam point and 28.11Ω at some unknown temperature θ . Calculate θ on the scale of this thermometer. (03marks)

$$\theta = \frac{R_\theta - R_0}{R_{100} - R_0} \times 100^\circ C = \frac{28.11 - 21.42}{29.10 - 21.42} \times 100^\circ C = 87.11^\circ C$$

35. (a) Define specific heat capacity of a substance and state its units (02marks)

Specific heat capacity is the amount of heat required to raise the temperature of 1kg mass of a substance by 1K of 1°C. Units JK⁻¹K⁻¹.

(b) (i) Describe how specific heat capacity of a liquid can be obtained by continuous flow method. (07marks)

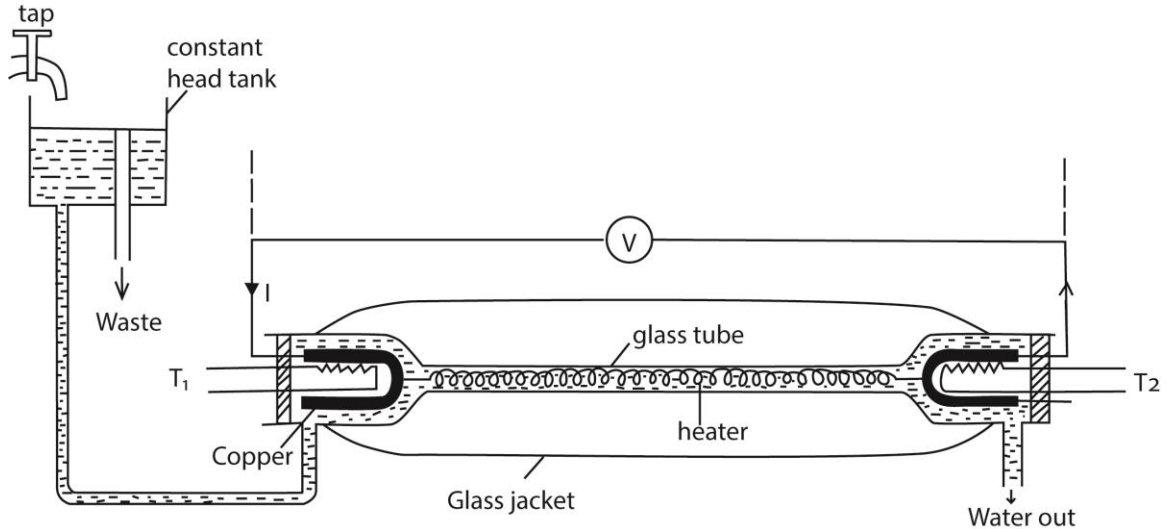

- A liquid is allowed to flow at constant rate
- Power is switched on and the liquid is heated until temperatures registered by T_1 and T_2 are steady and the values θ_1 and θ_2 respectively are recorded.
- The p.d V and current I are recorded from the voltmeter and ammeter respectively
- The mass, m of a liquid collected in time t is recorded
- At steady state; $VIt = mc(\theta_2 - \theta_1) + h$ (i)
- The rate of flow is changed and the voltage and current are adjusted until the steady readings of T_1 and T_2 are θ_1 and θ_2 respectively
- If m_1 , V_1 and I_1 are the values mass of liquid collected in time t , voltmeter and ammeter readings respectively, then

$$V_1 I_1 t = m_1 c (\theta_2 - \theta_1) + h \text{ (ii)}$$

Subtracting (ii) from (i)

$$c = \frac{(VI - V_1 I_1)t}{(m - m_1)(\theta - \theta_1)}$$

(ii) State one disadvantage of this method. (01mark)

- A large quantity of liquid is required
- Not suitable for all liquids

(c) An electric kettle rated 1000W, 240V is used on 220V mains to boil 0.52kg of water. If the heat capacity of the kettle is 400JK⁻¹ and the initial temperature of water is 20°C, how long will the water take to boil? (04marks)

$$P = \frac{V^2}{R}$$

$$\Rightarrow 1000 = \frac{240^2}{R}; R = 57.6\Omega$$

$$P \times t = mc\theta + C\theta$$

$$\frac{220^2}{57.6} = 0.52 \times 4200(100 - 20) + 400(100 - 20)$$

$$t = 246s$$

(d) (i) Distinguish between isothermal and adiabatic changes (02marks)

Isothermal change is a process which takes place at constant temperature while adiabatic change is a change which takes place in such a way that no heat enters or leaves the system

(ii) An ideal gas at 18°C is compressed adiabatically until the volume is halved. Calculate the final temperature of the gas. [Assume specific heat capacities of the gas at constant pressure and volume are $2100\text{Jkg}^{-1}\text{K}^{-1}$ and $1500\text{Jkg}^{-1}\text{K}^{-1}$] respectively. (04marks)

$$T_1 V_1^{\gamma-1} = T_2 V_2^{\gamma-1}$$

$$\gamma = \frac{2100}{1500} = 1.40$$

$$\Rightarrow 291(V)^{1.4-1} = T_2 \left(\frac{V}{2}\right)^{1.4-1}$$

$$T_2 = 384\text{K}$$

36. (a) State Stefan's law of black body radiation. (01marks)

Stefan's law states that the energy radiated per second per unit area of black body is proportional to the fourth power of the temperature of the body in Kelvin.

(b) Briefly describe how a thermopile can be used to detect thermal radiation. (05marks)

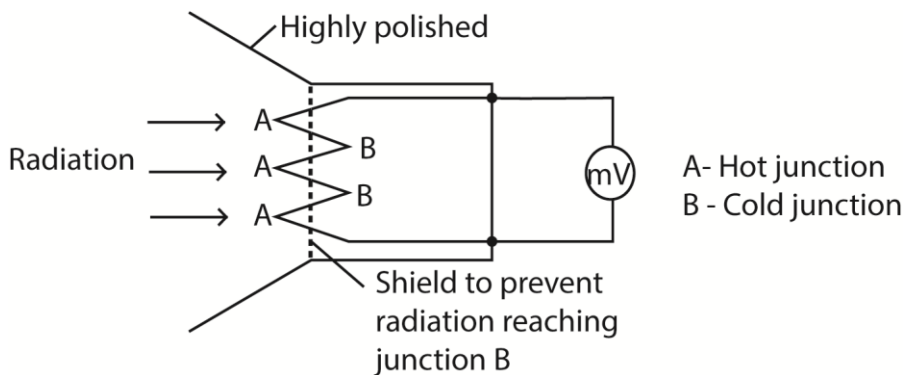

Radiation falling on junction A is absorbed and temperature rises above that of junction B. An e.m.f is generated and is measured by millivolt meter which deflects as a result.

(c) Explain the temperature distribution along

(i) a perfectly lagged metal bar (02marks)

When a metal is fully lagged, no heat is lost to the surroundings. The rate of heat flow along the metal bar is the same making the fall in temperature along the bar is uniform,

(ii) an unlagged metal bar. (02marks)

For a fully unlagged metal, heat lost to the surroundings. The rate of heat flow along the bar is not the same. Hence temperature gradient along the bar decreases with distance from the hot end to the cold end.

(d) The wall of a furnace is constructed with two layers. The inner layer is made of bricks of thickness 10.0cm and thermal conductivity $0.8 \text{ Wm}^{-1}\text{K}^{-1}$ and the outer layer is made of material of thickness 10.0 cm and thermal conductivity $1.6 \text{ Wm}^{-1}\text{K}^{-1}$.

The temperatures of the inner and outer surfaces are 600°C and 460°C respectively.

(i) Explain why in steady state, the rate of thermal energy transfer must be the same in both layers. (01mark)

Rate of the thermal energy transfer is the same because no heat is lost transverse to the direction of heat flow.

(ii) Calculate the rate of heat flow per square meter through the wall. (05marks)

$$\frac{Q}{t} = kA \left(\frac{\theta_2 - \theta_1}{l} \right)$$

$$\frac{0.8A(600 - \theta)}{10 \times 10^{-2}} = \frac{1.6A(\theta - 460)}{10 \times 10^{-2}}$$

$$\theta = 506.7^\circ$$

$$\frac{Q}{t} = \frac{0.8A(600 - 506.7)}{10 \times 10^{-2}} = 746.4 \text{ Wm}^{-2}$$

(e) Explain the greenhouse effect and how it is related to global warming. (04marks)

Short wavelength radiation from the sun passes through glass of green house. This is absorbed by plants and soil leading to increase in temperature. Plants and soil reradiate long wavelength radiations which cannot penetrate the glass and trapped in the greenhouse leading to higher temperature inside the greenhouse.

Water vapour, carbon dioxide, CFC and other greenhouse gases exhibit the same selective absorption effect in the temperature, making the earth to high temperature by absorbing short wavelength radiation.

The earth reradiates long wavelength radiation which is absorbed by the layers of greenhouse gases. This leads to increased temperature over the earth and after a long time may lead to global warming.

37. (a) (i) Define the term specific heat capacity and internal energy and state their units. (03marks)

Specific heat capacity is the amount of heat required to raise the temperature of 1kg mass of a substance by 1K of 1°C .

Internal energy is the total of the kinetic energy of atoms and molecules and the parallel potential energy due to mutual interactions of these atoms. Units: joules.

(ii) Why is the distinction between specific heat capacity at constant pressure and that at constant volume important for gases, but less important for solids and liquids? (04marks)

The volume of solids and liquids change very little when heated at constant pressure compared with volume changes for gas for the same temperature changes. Thus solid and liquids do very

little work against atmospheric pressure. This implies that there is very little difference in energy when they expand and when they are allowed to expand.

- (b) Explain why the temperature of a liquid does not change when the liquid is boiling? (02marks)

When the liquid boils, there is change in a state to vapour and all the heat supplied is used to do work by breaking the molecular bonds of the liquid. The temperature will not change until all the bonds broken.

- (c) One kilogram of water is converted to steam at a temperature of 100°C and a pressure of $1.0 \times 10^5 \text{Pa}$. If the density of steam is 0.58kgm^{-3} and specific heat of vaporization of water is $2.3 \times 10^6 \text{Jkg}^{-1}$, calculate the

- (i) external work done (04marks)

$$\text{Volume of 1kg of steam} = \frac{m}{\rho} = \frac{1}{0.58} = 1.724 \text{m}^3$$

$$\text{Volume of 1kg of steam} = \frac{m}{\rho} = \frac{1}{1000} = 0.001 \text{m}^3$$

$$\text{Change in volume} = 1.724 - 0.001 = 1.723 \text{m}^3$$

$$\text{Work} = p\Delta V = 1.0 \times 10^5 \times 1.723 = 1.723 \times 10^5 \text{J}$$

- (ii) internal energy (03marks)

$$\begin{aligned}\Delta u &= \Delta Q - \Delta w \\ &= 2.3 \times 10^6 - 1.723 \times 10^5 \\ &= 2.13 \times 10^6 \text{J}\end{aligned}$$

- (d) Explain why the specific latent heat of fusion and specific latent heat of vaporization of a substance at the same pressure are different. (04marks)

Change from solid to liquid, intermolecular bonds are weakened and there is a small increase in volume. This implies there negligible change in volume and thus little work done against atmospheric pressure.

During vaporization, a lot of heat is required to break molecular bonds in a liquid and to enable expansion to larger volume of a gas against atmospheric pressure.

38. (a) (i) Explain the difference between isothermal and adiabatic expansion of a gas. (02marks)

Isothermal expansion takes place at constant temperature.

Adiabatic expansion takes place at constant heat.

- (ii) Using same axes and point, sketch graphs of pressure versus volume for fixed mass of a gas undergoing isothermal and adiabatic changes. (03marks)

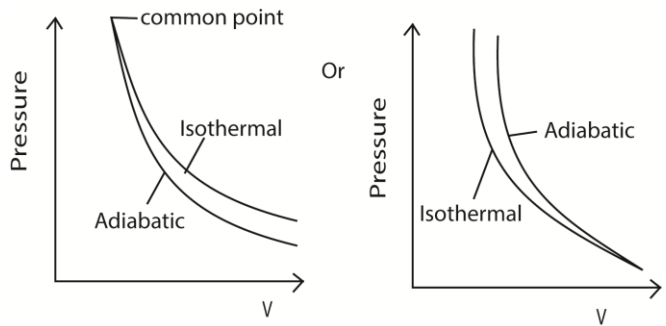

(b) Show that work, W , done by a gas which expands reversibly from V_0 to V_1 is given by

$$W = \int_{V_0}^{V_1} P dv \quad (04\text{marks})$$

If the piston is moved through a small distance dx , so that the pressure P is constant then

$$dw = Fdx$$

$$\text{but } F = PA; \Rightarrow dw = PAdx; \text{ also, } Adx = dv$$

$$\therefore dw = Pdv$$

$$\Rightarrow W = \int_{V_0}^{V_1} Pdv$$

(c) (i) State two differences between real and ideal gases (02marks)

Real gas	Ideal gas
Intermolecular force are appreciable	Intermolecular forces are negligible
Volume of molecules compared to the volume of the container is not negligible	Volume of molecules compared to the volume of container is negligible
Obey Boyle's law at high temperature and very low pressure	Obey Boyle's law at all temperatures and pressures.

(ii) Draw a labelled diagram showing P-V isotherms for a real gas above and below the critical temperature. (03marks)

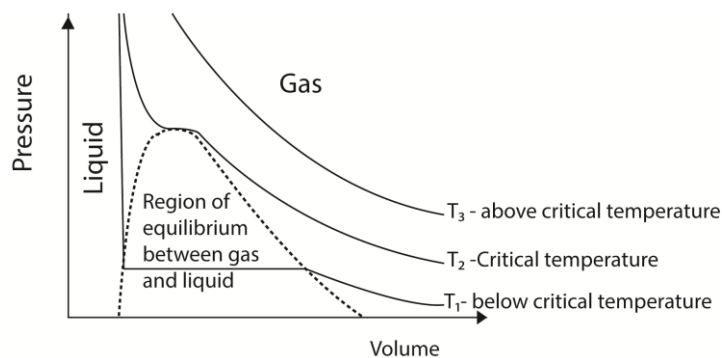

- Above the critical temperature a gas obeys Boyle's law.
- Below the critical temperature a gas exist as unsaturated vapour at low pressure when the pressure is increase it condenses until all the gas is turned into a liquid.

- (d) Ten moles of a gas, initially at 27°C are heated at constant pressure of $1.01 \times 10^5 \text{ Pa}$ and volume increased from 0.25 m^3 to 0.375 m^3 . Calculate the increase in internal energy.

[Assume $C_p = 28.5 \text{ J mol}^{-1} \text{ K}^{-1}$] (06marks)

$$T_1 = 27^\circ\text{C} = 300\text{K}$$

$$\text{Using } \frac{V_1}{T_1} = \frac{V_2}{T_2}$$

$$\frac{0.250}{300} = \frac{0.375}{T_2}; T_2 = 450\text{K}$$

$$\Delta T = 450 - 300 = 150\text{K}$$

$$\Delta Q = \Delta U + \Delta w$$

$$nC_p \Delta T = nC_v \Delta T + nR \Delta T$$

$$nC_v \Delta T = nC_p \Delta T - nR \Delta T$$

$$= 10 \times 28.5 \times 150 - 10 \times 8.31 \times 150$$

$$= 3.03 \times 10^4 \text{ J}$$

39. (a) What is meant by the following?

- (i) Conduction

Conduction is the process of heat transfer through a substance from a region of high temperature to a region of low temperature without bulk movement of the medium; mainly by collision between atoms that vibrate about equilibrium positions.

- (ii) Convection

Convection is a process of heat transfer in fluids from a region of high temperature to a region of low temperature, due to movement of the medium. Heated fluid become less dense and rises up and is replaced by cold denser fluid.

- (iii) Greenhouse effect (06marks)

Solar radiation of short wavelengths is absorbed by the earth's surface. The earth radiates long wavelength radiations which are trapped by the atmosphere leading to global warming.

- (b) One end of a long copper bar is heated in a steam chest and the other end is kept cool by current of circulating water. Explain with the aid of sketch graphs, the variation of temperature along the bar, when steady state has been attained if the bar is

- (i) lagged (02marks)

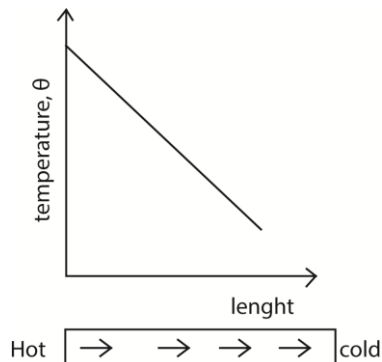

The rate of heat flow along the bar is constant since heat loss is negligible.

(ii) exposed to the surrounding (02marks)

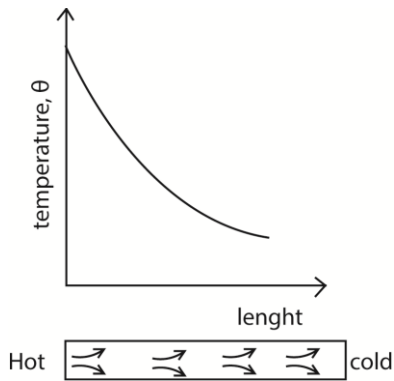

The rate of heat flow decrease with length due to heat losses

(c) (i) What is meant by a black body? (01mark)

A black body is one that absorbs all the radiations incident on it, reflects none and transmits none.

(ii) Describe how a black body can be approximated in practice. (04marks)

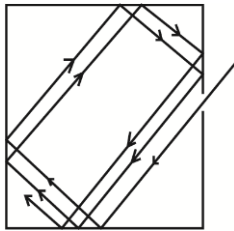

When radiation enters a black container through a hole, it undergoes multiple reflections. At each reflection, part of the radiation is absorbed. After several reflections, all the radiation is retained inside the container. Hence it approximates to a black body.

(d) (i) State Prevost's theory of heat exchange. (01mark)

A body at constant temperature is in of dynamic equilibrium with its surroundings. The rate of radiation being equal to the rate of absorption.

(ii) Sketch the variation with wavelength of the intensity of radiation emitted by a black body at two different temperatures. (01mark)

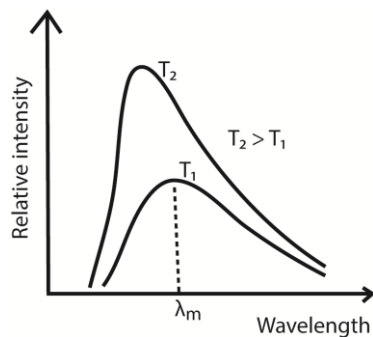

- For every wave length, relative intensity increases as temperature is increased.
- The wavelength at which maximum intensity occur shifts to the shorter wavelength as temperature is increased.
- λ_{\max} is the wavelength of radiation emitted at maximum intensity/emission of a black body at a particular temperature.

(e) A cube of side 1.0cm has a grey surface that emits 50% of the radiation emitted by a black body at the same temperature. If the cube's temperature is 700°C , calculate the power radiated by the cube. (03marks)

$$P = \sigma AT^4$$

$$T = 700 + 273 = 973\text{K}$$

$$\therefore P = 0.5 \times 5.67 \times 10^{-8} \times (6 \times 10^{-4}) \times 973^4 = 15.25\text{W}$$

40. (a) (i) Define the term thermometric property. (01mark)

Thermometric property is a physical property that vary uniformly and continuously with temperature.

(iii) State two thermometric properties. (01mark)

- Volume of constant mass of a gas at constant pressure
- Pressure of a gas at constant volume
- Electrical resistance of a platinum wire
- e.m.f of a thermocouple

(iv) With the aid of a labelled diagram, describe how the room temperature can be measured using uncalibrated resistance thermometer. (06marks)

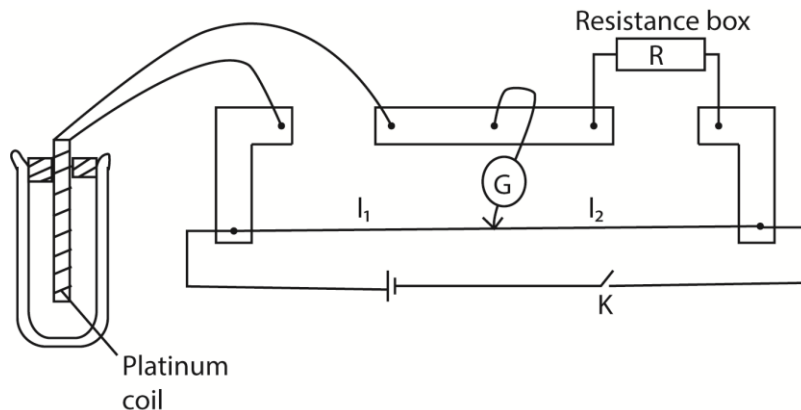

- Place the resistance thermometer in a funnel with crushed ice and leave it for some time.
- Close the switch and obtain a balance point by adjusting the resistance box,
- Determine the resistance R_0 at 0°C from $R_0 = \left(\frac{l_1}{l_2}\right) R$
- Transfer the resistance thermometer a beaker containing boiling water and after some time, determine resistance R_{100} .
- Place the resistance thermometer in water at room temperature and determine resistance R_{θ} .
- Temperature of the room temperature, $\theta = \left(\frac{R_{\theta} - R_0}{R_{100} - R_0}\right) \times 100^{\circ}\text{C}$

(b) (i) Define specific heat capacity of a substance. (01mark)

Specific heat capacity is the amount of heat required to raise the temperature of 1kg mass of a substance by 1K of 1°C.

(ii) Hot water at 85°C and cold water 10°C are ran into a bath at a rate of $3.0 \times 10^{-2} \text{m}^3 \text{min}^{-1}$ and V, respectively. At the point of filling the bath, the temperature of the mixture of water 40°C. Calculate the time taken to fill the bath is its capacity is 1.5m^3 .

$$V\rho tC(40 - 10) = 3.0 \times 10^{-2}\rho tC(85 - 40)$$

$$30V = 3.0 \times 10^{-2} \times 45$$

$$V = 4.5 \times 10^{-2} \text{m}^3 \text{min}^{-1}$$

At time of filling; total volume = volume of hot water + volume of cold water.

$$1.5 = 4.5 \times 10^{-2} \times t + 3.0 \times 10^{-2} \times t$$

Time, t = 20minutes.

(c) The specific latent heat of fusion of a substance is significantly different from its specific latent heat of vaporization at the same pressure. Explain how the difference arises. (04marks)

During evaporation, more energy is need to break intermolecular forces of attraction to form a gas and work done is done against atmospheric pressure by the expanding gas.

During fusion, energy is supplied to weaken the molecular bonds in solids accompanied by a small increase in volume. This implies negligible work done against atmospheric pressure.

(d) Explain in terms of specific heat capacity why water is used in a car radiator other than any other liquid. (02mark)

Water has very high specific heat capacity, hence high amount of heat lead to small increase in temperature of water compared to the change in temperatures in equal masses other liquids with low specific heat capacities.

41. (a) (i) state Boyles law. (01mark)

Boyle's law states that the pressure of a fixed mass of a gas at constant temperature is inversely proportional to the volume of the gas.

(ii) Describe an experiment that can be used to verify Boyles' law. (06marks)

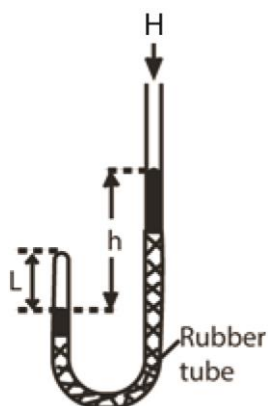

- air in the closed limb of a U-tube barometer as shown above
- mercury is poured to a height, h , and the length of the air column, L is noted.
- the length h is varied to obtain different sets of values of h and L
- Pressure of the gas is calculated from $P = (H + h)\rho g$ where H = height of barometer corresponding to atmospheric pressure, ρ = density of mercury, g = acceleration due to gravity. Note that h can be positive or negative.
- If A is the cross section area, $V = AL$
- Values of h , L , P , V and $1/V$ are tabulated
- A plot of P against $1/V$ gives a straight line through the origin which verifies Boyle's law.

(b) Explain the following observations using the kinetic theory.

(i) A gas fills any container in which it is placed and exerts pressure on its walls. (03marks)

A gas contains molecules with negligible intermolecular forces and free to move in all directions. As they move, they collide with each other and with the walls of the container. The unrestricted movements make them to fill the available space and collisions with the walls contributes to the pressure exerted on the wall.

(ii) The pressure of a fixed mass of a gas rises when temperature is increased at constant volume. (02 marks)

When the temperature of a gas increases, the kinetic energy of the gas molecules increases. This increases the frequency and force of collision against the wall leading to increase in pressure.

(c) (i) What is meant by a reversible process. (01marks)

A reversible process is one that takes place in reverse direction through the same values of pressure, volume and temperature in small changes or steps.

(ii) State the conditions necessary for isothermal and adiabatic processes to occur, (04marks)

Isothermal process occurs at constant temperature and therefore the gas must be enclosed in thin walled container of good thermal conductivity placed in a large heat reservoir and occurs slowly enough to allow heat exchange with the surrounding.

Adiabatic process requires no heat input or out and therefore should occur rapidly in well insulated container like a thermos flask and gas should be ideal.

(d) A mass of an ideal gas of volume 200cm^3 at 144K expands adiabatically to a temperature of 137K . Calculate its new volume. (Take $\gamma = 1.40$)

$$T_1 V_1^{\gamma-1} = T_2 V_2^{\gamma-1}$$

$$\gamma = \frac{2100}{1500} = 1.40$$

$$\Rightarrow 144(200)^{1.4-1} = 137(V)^{1.4-1}$$

$$V = 226.5\text{cm}^3$$

42. (a) Define thermal conductivity. (01mark)

Thermal conductivity is the rate of heat flow per unit area per unit temperature gradient.

(b)(i) Explain the mechanism of thermal conduction in nonmetallic solids. (03marks)

In solids the atoms are loosely packed and have strong intermolecular forces as they vibrate within a fixed lattice. When one end is heated, the atoms vibrate with bigger amplitudes, collide with the neighboring atoms and lose their vibration energy to them. These also vibrate more vigorously and collide and lose their vibration energy to them. In this way, heat is propagated throughout the solids.

(ii) Why are metal better thermal conductors than nonmetallic solids? (02marks)

In metals there are free electrons which gain kinetic energy when heat and move faster and for a longer distance to pass over their energy to other atoms they collide with. This occurs in addition to the transfer of heat by vibrating atoms as it occurs in nonmetallic solids.

(c) With the aid of a diagram, describe an experiment to determine the thermal conductivity of a poor conductor. (06marks)

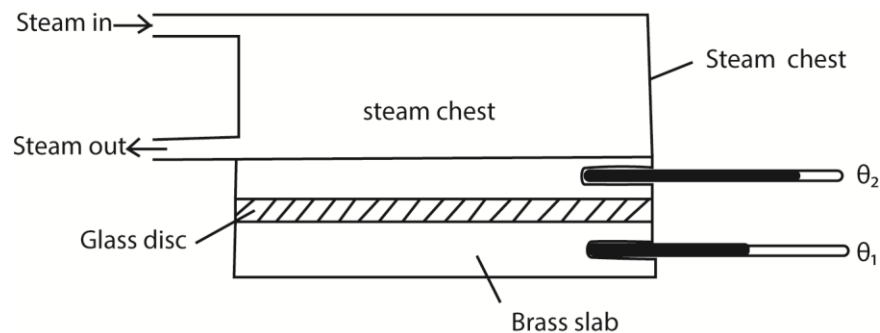

- Glass is cut in form of a thin disc of cross section area, A and thickness, x.
- The disc is sandwiched between a steam chest and brass slab of mass, m and specific heat capacity, c.
- Steam is passed through the chest until the thermometers register steady temperatures, θ_1 and θ_2 .
- Then, $\frac{\theta}{t} = kA \left(\frac{\theta_2 - \theta_1}{x} \right)$
- The glass disc is removed and brass slab is heated directly by steam chest, until its temperature is about 10°C above θ_1 .
- Steam chest is removed and the top of the glass slab is covered by the glass disc.
- The temperature of the slab is recorded at suitable time interval until its temperature is about 10°C below θ_1 .

- A graph of temperature against time is plotted and its slope s determined at θ_1

$$\frac{\theta}{t} = mcs$$

$$\therefore kA \left(\frac{\theta_2 - \theta_1}{x} \right) = mcs$$

$$k = \frac{mcsx}{A(\theta_2 - \theta_1)} \text{ but } A = \frac{\pi D^2}{4}$$

$$\therefore k = \frac{4mcsx}{\pi D^2(\theta_2 - \theta_1)}$$

- (d) (i) What is meant by a black body? (01mark)

A black body is one that absorbs all incident radiations on it, transmits and reflects none.

- (ii) Sketch curves showing the spectral distribution of energy radiated by a black body at three different temperatures. (02marks)

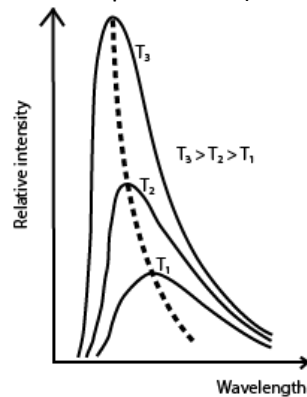

- (iii) Describe the main features of the curves you have drawn in (d)(ii) (02marks)

- For every wave length, relative intensity increases as temperature is increased.
- The wavelength at which maximum intensity occur shifts to the shorter wavelength as temperature is increased.
- λ_{max} is the wavelength of radiation emitted at maximum intensity/emission of a black body at a particular temperature.

- (e) A small blackened solid copper sphere of radius 2cm is placed in an evacuated enclosure whose wall are kept at 100°C . Find the rate at which energy must be supplied to the sphere to keep its temperature at 127°C . (03marks)

$$P = \sigma A(T_2^4 - T_1^4)$$

$$= \sigma 4\pi r^2(T_2^4 - T_1^4)$$

$$= 5.67 \times 10^{-8} \times 4\pi (2 \times 10^{-2})^2 (400^4 - 372^4)$$

$$= 1.78\text{W}$$

43. (a) Define the following terms

- (i) Specific latent heat of vaporization (01mark)

Specific latent heat of vaporization is the amount of heat energy required to change 1kg mass of a liquid to vapour at constant temperature.

(ii) Coefficient of thermal conductivity

Thermal conductivity is heat flow per second per unit area per unit temperature gradient.

(b) With the aid of a labelled diagram, describe an experiment to measure the specific latent heat of vaporization of water by electrical method (07marks)

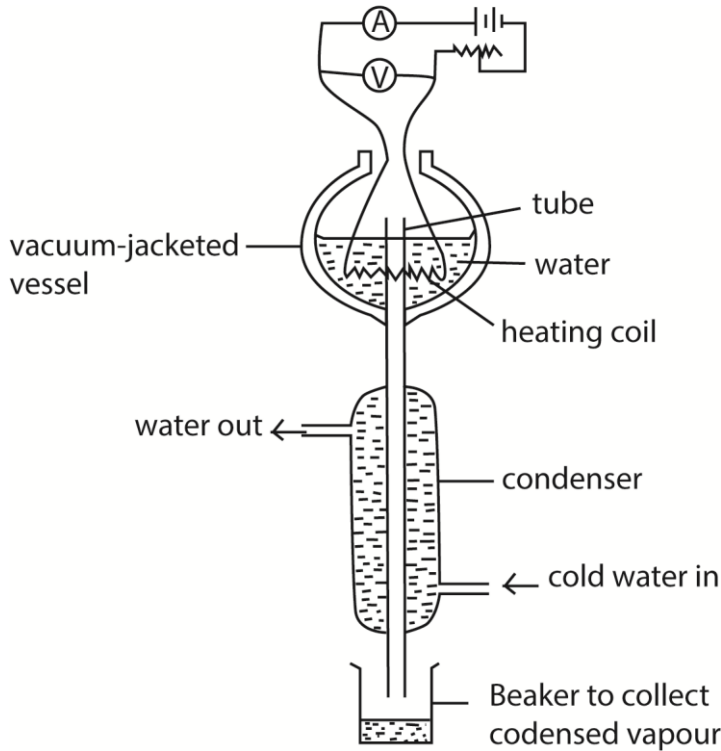

- Put the liquid whose specific latent heat of vaporization is required in a vacuum jacketed vessel as shown above.
- The liquid is heated to boiling point.
- The current, I , and voltage, V are recorded.
- The mass of condensed water, m , condensed in time, t , is determined.
- Then $IV = \frac{m}{t}L + h$, where h is the rate of heat loss to the surroundings
- To eliminate, h , the experiment is repeated for different values of I' and V' and the mass of the condensed water, m' condensed in tie t is determined.
- Again $I'V' = \frac{m'}{t}L + h$

$$\text{Latent heat of vaporization, } L = \frac{(I'V' - IV)t}{(m' - m)}$$

(c) An appliance rated 240V, 200W evaporates 20g of water in 5 minutes. Find the heat loss if specific latent heat of vaporization is $2.26 \times 10^6 \text{Jkg}^{-1}$. (03marks)

$$\text{Electrical energy supplied} = mlv + h$$

$$\text{Power} \times \text{time} = mlv + h$$

$$200 \times 5 \times 60 = 20 \times 10^{-3} \times 2.26 \times 10^6 + h$$

$$h = 14800\text{J}$$

(d) Explain why at a given external pressure a liquid boils at constant temperature. (04marks)

A liquid boils when its saturated vapour pressure equals the external pressure. Since saturated vapour pressure depends on temperature of a liquid, it implies that for a given external pressure, boiling occurs at constant temperature.

(e) With the aid of a suitable sketch graphs, explain the temperature distribution along lagged and unlagged metal rods, heated at one end. (04marks)

(i) lagged

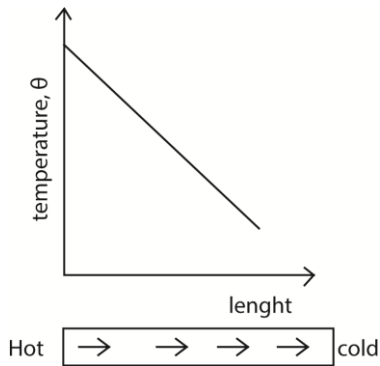

The rate of heat flow along the bar is constant since heat loss is negligible.

(ii) unlagged bar

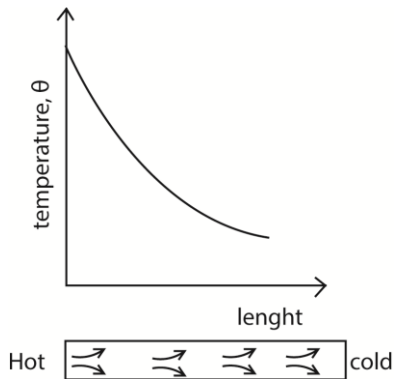

The rate of heat flow decrease with length due to heat losses

44. (a) Describe an experiment to verify Newton's law of cooling. (05marks)

- Hot water is placed in a calorimeter that is standing on an insulating surface and is put in a draught.
- The temperature, θ , of the water is recorded at suitable intervals.

- The room temperature θ_R is recorded.
- Plot a graph of temperature against time to get a graph similar to the one below.

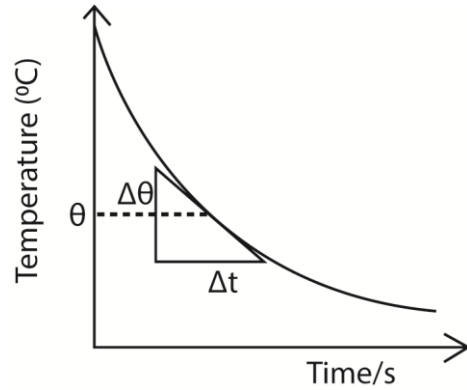

- Draw tangent at various temperatures, θ and obtain their slopes. These slopes give the rate of temperature fall.
- Plot these slopes with corresponding excess temperatures $(\theta - \theta_R)$
- A straight line graph is obtained implying that the rate of heat loss is proportional to excess temperature.

(b) (i) Distinguish between a real and an ideal gas. (03marks)

Real gas	Ideal gas
Intermolecular force are appreciable	Intermolecular forces are negligible
Volume of molecules compared to the volume of the container is not negligible	Volume of molecules compared to the volume of container is negligible
Obey Boyle's law at high temperature and very low pressure	Obey Boyle's law at all temperatures and pressures.

(ii) Derive the expression

$$P = \frac{1}{3} \rho \bar{c}^2 \text{ for the pressure of an ideal gas of density, } \rho, \text{ and mean square speed } \bar{c}^2$$

Consider a molecule of mass, m , moving in a cube of length, l and velocity, u .

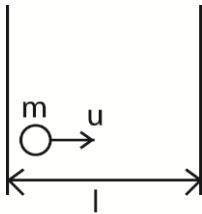

$$\text{Change in momentum} = mu - (-mu) = 2mu$$

$$\text{Rate of change of momentum} = \frac{2mu}{t}$$

$$\text{Time, } t, \text{ between collision} = \frac{2l}{u}$$

$$F_1 = 2mu \div \frac{2l}{u} = \frac{mu^2}{l}$$

For N molecules, force on the wall,

$$F = \frac{mu_1^2}{l} + \frac{mu_2^2}{l} + \frac{mu_3^2}{l} + \dots + \frac{mu_N^2}{l}$$

Pressure, $P = \frac{F}{A} = \frac{m}{l^3} (u_1^2 + u_2^2 + u_3^2 + \dots + u_N^2)$ since $A = l^2$

$$u^2 = \frac{u_1^2 + u_2^2 + u_3^2 + \dots + u_N^2}{N}$$

$$Nu^2 = u_1^2 + u_2^2 + u_3^2 + \dots + u_N^2$$

$$\therefore P = \frac{Nm u^2}{l^3} = \rho u^2; \text{ since } \rho = \frac{Nm}{l^3}$$

$$c^2 = u^2 + v^2 + w^2 \text{ and } u^2 = v^2 + w^2$$

$$\therefore c^2 = 3u^2 \Rightarrow u^2 = \frac{1}{3}c^2$$

$$\therefore P = \frac{1}{3}\rho c^2$$

(c) (i) Explain why the pressure of a fixed mass of a gas in a closed container increases when the temperature of the container is raised. (02marks)

When the temperature of the container increases, the average velocity of the molecules increases. So the number and force of collisions with the walls of the container per second increases. Consequently the momentum change per second increases as they bombard the walls. This leads to increase in the impulsive force exerted on the walls causing increase in pressure.

(ii) Nitrogen gas is trapped in a container by a movable piston. If the temperature of the gas is raised from 0°C to 50°C at constant pressure of $4.0 \times 10^5\text{Pa}$ and the total heat added is $3.0 \times 10^4\text{J}$, calculate the work done by the gas. [The molar heat capacity of nitrogen at constant pressure is $29.1\text{Jmol}^{-1}\text{K}^{-1}$, $C_p/C_v = 1.4$]

$$\Delta Q = \Delta U + \Delta w \dots\dots\dots(i)$$

$$C_v = \frac{C_p}{1.4} = \frac{29.1}{1.4} = 20.79\text{Jmol}^{-1}$$

$$\Delta Q = nC_1\Delta T$$

$$n = \frac{\Delta Q}{C_1\Delta T} = \frac{3 \times 10^4}{29.1 \times 50} = 20.62$$

From equation (i)

$$3 \times 10^4 = 20.62 \times 20.79 (50-0) + \Delta w$$

$$\Delta w = 8.57 \times 10^3\text{J}$$

45. (a) (i) State the laws of black body radiation (02marks)

- The wavelength λ_m at which maximum energy is radiated for temperature, T is such that $\lambda_m T = \text{constant}$. (Wien's displacement law)
- If E_{λ_m} is the height of the peak of the curve for a temperature T, then $E_{\lambda_m} \propto T^6$
- The total energy radiated per square meter per second by a black body at temperature, T, is proportional to T^4 (Stefan's Boltzmann law)

(ii) Sketch the variation of intensity with wavelength in a black for different temperatures. (03marks)

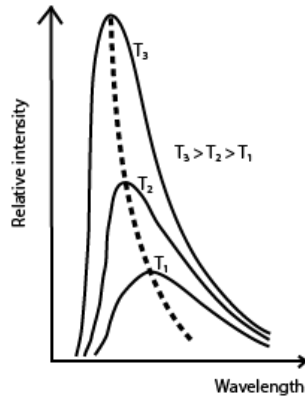

- For every wave length, relative intensity increases as temperature is increased.
- The wavelength at which maximum intensity occur shifts to the shorter wavelength as temperature is increased.
- λ_{\max} is the wavelength of radiation emitted at maximum intensity/emission of a black body at a particular temperature.

(b) (i) What is a perfectly black body? (01marks)

A perfect black body is one that absorbs all the radiation incident on it, but reflects and transmits none.

(ii) How can a perfectly black body be approximated in reality? (04marks)

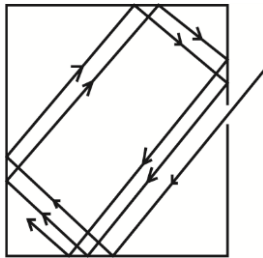

When radiation enters a black container through a hole, it undergoes multiple reflections. At each reflection, part of the radiation is absorbed. After several reflections, all the radiation is retained inside the container. Hence it approximates to a black body.

(c)(i) The energy intensity received by a spherical planet from a star is $1.4 \times 10^3 \text{ Wm}^{-2}$. The star is of radius $7.0 \times 10^5 \text{ km}$ and is $14.0 \times 10^7 \text{ km}$ from the planet.

(i) Calculate the surface temperature of the star. (04marks)

$$\begin{aligned} \text{Incident energy per second (power) on a unit of planet} &= \frac{4\pi r_s^2 \sigma T^4}{4\pi R^2} \\ &= \left(\frac{r_s}{R}\right)^2 \sigma T^4 \end{aligned}$$

Where r_s and R are the radii of the star and the distance of the star from the planet respectively.

$$1.4 \times 10^3 = \left(\frac{r_s}{R}\right)^2 \sigma T^4$$

$$T = \left[\frac{1.4 \times 10^3}{\sigma} \times \left(\frac{R}{r_s}\right)^2 \right]^{\frac{1}{4}} = \left[\frac{1.4 \times 10^3}{5.67 \times 10^{-8}} \times \left(\frac{14 \times 10^{10}}{7 \times 10^8}\right)^2 \right]^{\frac{1}{4}} = 5605.98 \text{ K}$$

(ii) State any assumptions you have made in (c)(i) above (01marks)

- The star is spherical
- The star radiates as a black body
- There is no heat loss to the sphere

(d) (i) What is convection? (01mark)

Convection is the transfer of heat in fluids by bulk movement of the fluid itself.

(ii) Explain the occurrence of land and sea breeze. (04marks)

During day, the land is heated to a high temperature than the sea. Hot air expands and rises from land. A stream of cool air from the sea blows towards the land to replace the uprising air, hence sea breeze occurs.

At night the land cools faster because it is no longer heated by the sun. The sea retains the warmth because it is heated deeply. Warm less dense air rises from the sea surface and air from land blows to replace it leading to land breeze.

46. (a) (i) Define a thermometric property and give two examples (02marks)

Thermometric property is a physical measurable property that varies linearly and continuously with temperature and is constant at constant temperature.

Examples

- Volume of constant mass of a gas at constant pressure
- Pressure of a gas at constant volume
- Electrical resistance of a platinum wire
- e.m.f of a thermocouple

(ii) When is the temperature of 0K attained? (02marks)

0K is when molecules of a substance slow down and attain their minimum total energy

(b)(i) With reference to constant-volume gas thermometer, define temperature on the Celsius scale (02marks)

$$\theta = \frac{P_{\theta} - P_0}{P_{100} - P_0}$$

where θ is unknown temperature, P_{θ} is the pressure at unknown temperature, P_0 is the pressure at ice point and P_{100} is the pressure at steam point.

(ii) State two advantages and two disadvantages of the constant-volume gas thermometer. (02marks)

Advantages

- it has a wide range
- very accurate

Disadvantages

- it does not give direct reading
- cannot measure rapidly changing temperatures.

(c) (i) Define triple point of water (01mark)

Triple point of water is the temperature and pressure at which saturated water vapour, pure water and ice coexist in equilibrium.

- (ii) Describe how you would measure the temperature of a body on the thermodynamic scale using a thermocouple. (03marks)

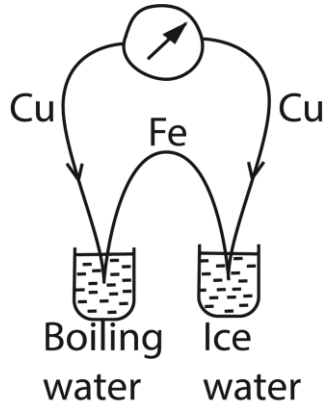

The e.m.f, E_{Tr} is obtained when a hot junction is placed in water at triple point. E.m.f, E_T is obtained at unknown temperature T .

$$T = \frac{E_T}{E_{Tr}} \times 273.16K$$

- (d) The resistance, R_θ of platinum varies with the temperature $^\circ C$ as measured by the constant-volume gas thermometer according to the equation

$$R_\theta = 50.0 + 0.17\theta + 3.0 \times 10^{-4}\theta^2$$

- (i) Calculate the temperature on the platinum scale corresponding to $60^\circ C$ on the gas scale. (06marks)

$$R_0 = 50\Omega$$

$$R_{60} = 50 + 0.17 \times 60 + 3.0 \times 10^{-4} \times 60^2 = 61.28\Omega$$

$$R_{100} = 50 + 0.17 \times 100 + 3.0 \times 10^{-4} \times 100^2 = 70.00\Omega$$

$$\begin{aligned} \theta &= \frac{R_\theta - R_0}{R_{100} - R_0} \times 100^\circ C \\ &= \frac{61.28 - 50}{70 - 50} \times 100 \\ &= 56.4^\circ C \end{aligned}$$

- (ii) Account for the difference between the two values and state the temperatures at which they agree. (02marks)

Difference thermometric properties vary differently with temperature.

47. (a) (i) Define latent heat (01mark)

Latent heat is the amount of heat required to change a unit mass of a substance from one state to another at constant temperature.

- (ii) Explain the significance of latent heat in regulation of body temperature (03marks)

On a hot day, the body sweats. Evaporation occurs at the surface of the body leading to the cooling of the body since the evaporating water draws heat from the body.

- (b) (i) using kinetic theory, explain boiling of a liquid (03mark)

Molecules of a liquid through moving randomly have attractive forces between them. When a liquid is heated, the molecules move faster and forces of attraction weakened until they are

overcome at the boiling temperature. At this point, saturated vapour pressure (SVP) of liquids is equal to external pressure. Liquid molecules with enough energy escape from the bulk to the atmosphere.

(ii) Describe how you would determine the specific latent heat of vaporization of water by the method of the mixtures (05marks)

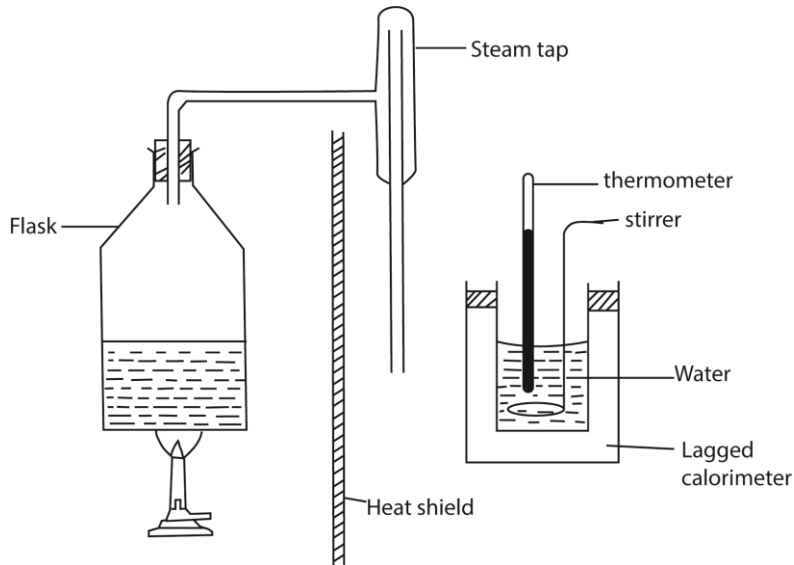

- The initial temperature θ_0 and mass, m of water in the calorimeter are measured
 - Steam from boiling water is passed into water in a calorimeter and after a reasonable temperature rise, flow of steam is stopped and final temperature, θ_f is recorded.
 - Mass m_2 of water in the calorimeter is then taken
 - The mass of steam condensed, $m_s = (m_2 - m)$
- Given that the heat capacity of the calorimeter = C
 Heat gained by steam = heat gained by water and calorimeter
 $m_s c_v + m_s c(100 - \theta_f) = (m_2 - m)c(\theta_f - \theta_0) + C(\theta_f - \theta_0)$
 c_v = specific latent heat of vaporization
 c = specific heat capacity of water

(iii) Explain why latent heat of vaporization is always greater than that of fusion. (02marks)
 In evaporation energy is needed to break intermolecular forces of attraction and to expand against atmospheric pressure while in fusion, energy is needed to weaken molecular attraction only.

(c) In an experiment to determine the specific latent heat of vaporization of a liquid using the continuous flow calorimeter, the following results were obtained.

Voltage, V/V	Current, I/A	Mass collected in 300s/g
7.4	2.6	5.8
10.0	3.6	11.3

Calculate the power of the heater required to evaporate 3.0g of water in 2 minutes (06marks)

$$I_1 V_1 = m_1 l + h \dots\dots\dots(i)$$

$$I_2 V_2 = m_2 l + h \dots\dots\dots(ii)$$

From (i) and (ii)

$$l = \frac{I_2 V_2 - I_1 V_1}{m_2 - m_1} = \frac{10 \times 3.6 - 7.4 \times 2.6}{(11.3 \times 10^{-3} - 5.8 \times 10^{-3})/300} = 9.14 \times 10^5 \text{ J kg}^{-1}$$

$$m_3 = \frac{3.0 \times 10^{-3}}{2 \times 60} = 2.5 \times 10^{-5} \text{ kg s}^{-1}$$

$$l = \frac{I_2 V_2 - I_3 V_3}{m_2 - m_3}$$

$$9.14 \times 10^5 \text{ n} = (10 \times 3.6 - I_3 V_3) \div \left(\frac{11.3 \times 10^{-3}}{300} - 2.5 \times 10^{-5} \right)$$

$$11.59 = 36 - I_3 V_3$$

$$\text{Power} = I_3 V_3 = 36 - 11.59 = 24.41 \text{ W}$$

48. (a)

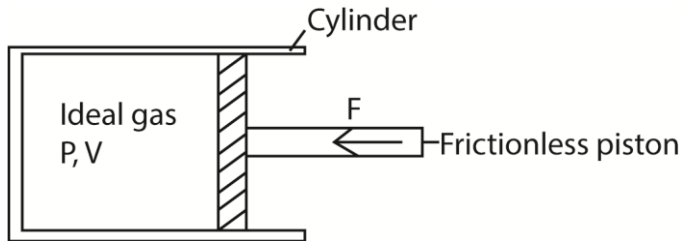

A fixed mass of an ideal gas is confined in a cylinder by frictionless piston of cross section area A . the piston is in equilibrium under the action of force, F as shown in the figure above. Show that the work done, W , by the gas when it expands from V_1 to V_2 is given by

$$W = \int_{V_1}^{V_2} P dV \quad (03 \text{ marks})$$

Suppose the gas expands by dv so that the piston moves out through a small distance dx .

Work done by the gas, $dW = F dx$

$$= P A dx$$

$$= P dv$$

Total work done during expansion from v_1 to v_2 is given by

$$W = \int_{v_1}^{v_2} P dv$$

(b) State the first law of thermodynamics and use it to distinguish between Isothermal and adiabatic changes in a gas. (05 marks)

$$\Delta Q = \Delta U + \Delta W = n C_v \Delta T + \Delta W$$

During isothermal expansion, $\Delta T = 0$. Therefore all the energy supplied is equal to the work done by the gas during expansion.

In adiabatic expansion, no heat enters or leaves the gas. Therefore $\Delta Q = 0$ and $\Delta U = -\Delta W$.

In adiabatic expansion, work is done at the expense of its internal energy. Therefore the gas cools.

(c) The temperature of 1 mole of helium gas at a pressure of $1.0 \times 10^5 \text{ Pa}$ increases from 20°C to 100°C when the gas is compressed adiabatically.

Find the final pressure of the gas. (Take $\gamma = 1.67$) (04 marks)

$$P_1 V_1^\gamma = P_2 V_2^\gamma$$

$$\text{but } V = \frac{nRT}{P} \Rightarrow \frac{P_1 T_1^{\gamma}}{P_1} = \frac{P_2 T_2^{\gamma}}{P_2}$$

$$\Rightarrow \frac{T_1^{\gamma}}{P_1^{\gamma-1}} = \frac{T_2^{\gamma}}{P_2^{\gamma-1}}$$

$$\frac{(293)^{1.67}}{(1.0 \times 10^5)^{0.67}} = \frac{(373)^{1.67}}{(P)^{0.67}}$$

$$P = 1.87 \times 10^5 \text{ Pa}$$

(d) With the aid of a P-V diagram, explain what happens when a real gas is compressed at different temperatures. (04marks)

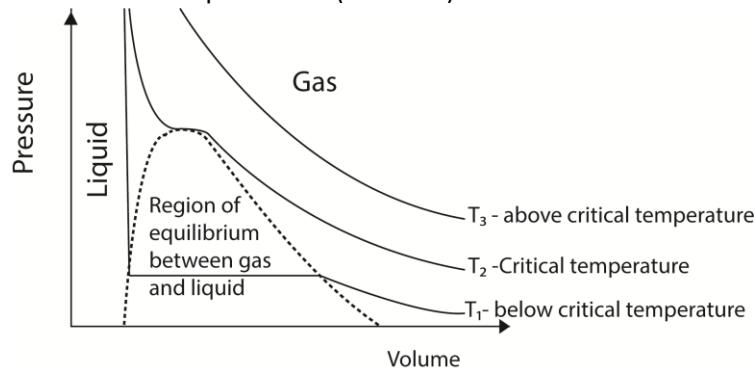

- Above the critical temperature a gas obeys Boyle's law.
- Below the critical temperature a gas exist as unsaturated vapour at low pressure when the pressure is increase it condenses until all the gas is turned into a liquid.

(e) The root-mean square speed of the molecules of a gas is 44.72 ms^{-1} . Find the temperature of the gas if its density is $9.0 \times 10^{-2} \text{ kg m}^{-3}$ and the volume is 42.0 m^3 . (04marks)

$$P = \frac{1}{3} \rho c^2$$

$$\Rightarrow \frac{RT}{V} = \frac{1}{3} \rho c^2$$

$$T = \frac{1}{3} \rho c^2 \times \frac{V}{R} = \frac{1}{3} \times 9.0 \times 10^{-2} \times (44.72)^2 \times \frac{42}{8.31} = 303.2 \text{ K}$$

49. (a) Define saturated vapour pressure (S.V.P) (01mark)

Saturated vapour pressure in the one in dynamic equilibrium with its own liquid

(b) Use the kinetic theory of matter to explain the following observations

(i) saturated vapour pressure of a liquid increases with temperature. (03marks)

Increase in temperature increases the kinetic energy of the liquid molecules and the rate of evaporation increases. Therefore the pressure of the vapour rises. As the rate at which the molecules bombard the liquid surface increases, dynamic equilibrium is restored at a higher saturated vapour pressure.

(ii) saturated vapour pressure is not affected by decrease in volume at constant temperature.

(03marks)

A decrease in volume leads to momentary increase in the density of the vapour. The rate of condensation increase than the rate of evaporation. As the density of the vapour falls the rate of condensation also falls. Dynamic equilibrium is re-established to original values of density and pressure of vapour. Therefore no increase in saturated vapour pressure.

(c) Describe how saturated vapour pressure of a liquid at various temperatures can be determined. (07marks)

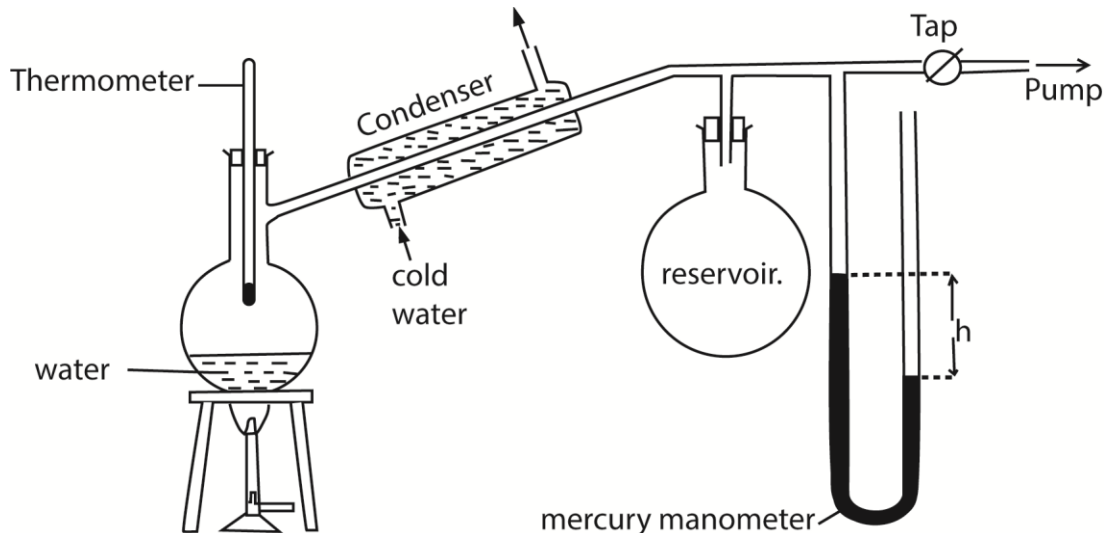

- The pressure of the air in R is shown by the mercury manometer; if its height is h , the pressure in mm mercury is $P = H - h$, where H is the barometer height.
- The tap is opened and the pressure above water varied using the pump to a suitable value.
- The tap is closed and water in the flask is heated until it boils.
- The temperature θ and difference in mercury levels, h , are noted and recorded.
- The saturated vapour pressure, $P = (H \pm h)$ is calculated
- The procedure is repeated for other values of θ and h
- A graph of P versus θ is plotted and the saturated vapour pressure at a particular temperature is obtained.

(d) (i) State Dalton's law of partial pressures (01mark)

Dalton's law of partial pressures states that the pressure of a mixture of gases that do not react chemically is the sum of partial pressures of its components.

(ii) A horizontal tube of uniform bore, closed at one end, has some air trapped by a small quantity of water. The length of the enclosed air column is 20cm at 12°C .

Find stating any assumptions made, the length of air column when the temperature is raised to 38°C .

[S.V.P of water at 12°C and 38°C are 10.5mmHg and 49.5mmHg respectively. Atmospheric pressure = 75cmHG] (05marks)

$T_1 = 273 + 12 = 285\text{K}$, $T_2 = 273 + 38 = 311\text{K}$; $P_1 = 750 - 10.5 = 739.5\text{mmHg}$, $P_2 = 750 - 49.5 = 700.5\text{mmHg}$

$$\frac{P_1 V_1}{T_1} = \frac{P_2 V_2}{T_2}$$

$$\frac{739.5 \times 20A}{285} = \frac{700.5 \times hA}{311}$$

$$h = 23.04\text{cm}$$

Assumption: the tube does not expand when the temperature increases.

50. (a) (i) Define specific heat capacity of a substance. (01mark)

Specific heat capacity is the energy required to raise the temperature of 1kg mass of a substance by 1K.

(ii) State three advantages of the continuous flow method over the method of mixtures in determination of the specific heat capacity of a liquid. (03marks)

- The heat capacity of the apparatus is not required.
- Heat loss is eliminated in the calculation
- Resistance thermometer can be used.
- Temperatures are read at leisure

(b) In a continuous flow experiment, a steady difference of temperature of 1.5°C is maintained when the rate of liquid flow is 4.5gs^{-1} and the rate of electrical heating is 60.5W . On reducing the liquid flow rate to 1.5gs^{-1} , 36.5W is required to maintain the same temperature difference.

Calculate the

(i) Specific heat capacity of the liquid. (04marks)

$$P = \frac{m}{t}c\theta + h$$

$$60.5 = 4.5 \times 10^{-3} \times c \times 1.5 + h \dots\dots\dots (i)$$

$$36.5 = 1.5 \times 10^{-3} \times c \times 1.5 + h \dots\dots\dots (ii)$$

Subtracting (ii) from (i)

$$24 = 3 \times 10^{-3} \times c \times 1.5$$

$$c = 5,333\text{Jkg}^{-1}\text{K}^{-1}$$

(ii) Rate of heat loss to the surroundings (03marks)

Substituting c in (i)

$$60.5 = 4.5 \times 10^{-3} \times 5333 \times 1.5 + h$$

$$h = 24.5\text{W}$$

(c) (i) Describe an electrical method for determination of the specific heat capacity of a metal. (06marks)

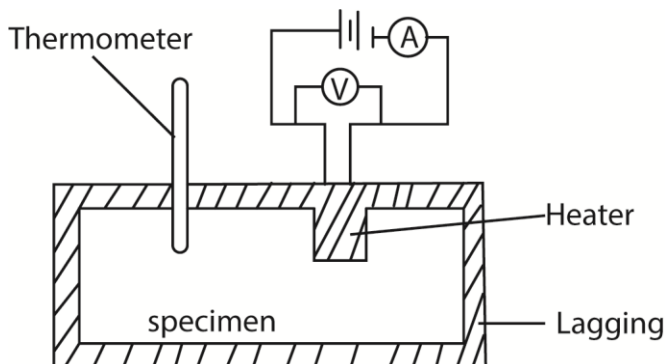

- Two holes are drilled into the specimen solid of mass m.
- A thermometer is inserted in one of the holes and an electric heater into the other hole. The holes are then filled with a good conducting fluid, e.g. oil to ensure thermal contact.
- The apparatus is insulated and initial temperature θ_0 is recorded.

- The heater is switched on at the same time a stop clock is started.
- The steady values of ammeter reading, I and voltmeter reading, V are recorded.
- After considerable temperature rise, the heater is switched off and stop clock stopped.
- The highest temperature θ_1 recorded and time t taken noted.
- The specific heat capacity, c, of the conducting solid is calculated from

$$c = \frac{IVt}{m(\theta_1 - \theta_0)}$$

(ii) State the assumptions made in the above experiment. (02marks)

- All heat supplied by the heater is gained by the metal block
 - The volume of the metal does not change.
- (iii) Comment about the accuracy of the results of the experiment in (c)(i) above. (01marks)
The value of specific heat capacity is accurate as long as there is not heat losses to the surrounding.

51. (a)(i) Define thermal conductivity. (01mark)

Thermal conductivity is the rate of heat flow per unit cross section area per unit temperature gradient.

(ii) Explain the mechanism of heat transfer in metals (03marks)

When one end of a metal is heated, the metal atoms gain energy and their vibration increase. These collide with the neighboring atoms giving them some of the energy. The neighboring atoms also vibrate with higher amplitudes and collide with their neighboring atom to which they give some of their energy. In this way heat is transferred from atom to atom.

Secondly, electrons gain kinetic energy and move and collide other electrons and atom delivering heat energy.

(b) Two brick walls each of thickness 10cm are separated by an air-gap of thickness 10cm. the outer faces of the brick walls are maintained at 20°C and 5°C respectively.

(i) Calculate the temperatures of the inner surfaces of the walls. (06marks)

$$\text{From } \frac{\Delta Q}{\Delta t} = kA \frac{\Delta \theta}{\Delta x}$$

$$k_b A \frac{(20 - \theta_1)}{0.1} = k_a A \frac{(\theta_1 - \theta_2)}{0.1} = k_b A \frac{(\theta_2 - 5)}{0.1}$$

$$0.6A \frac{(20 - \theta_1)}{0.1} = 0.2A \frac{(\theta_1 - \theta_2)}{0.1} = 0.6A \frac{(\theta_2 - 5)}{0.1}$$

$$\theta_1 = 19.5^\circ \text{ and } \theta_2 = 5.5^\circ\text{C}$$

(ii) Compare the rate of heat loss through the layer of air with that through a single brick wall. (03marks)

The rate of heat loss from a single brick wall is higher than that of the air because a brick is a better conductor.

[Thermal conductivity of air is $0.02\text{Wm}^{-1}\text{K}^{-1}$, and that of bricks is $0.6\text{Wm}^{-1}\text{K}^{-1}$]

(c)(i) State Stefan's law of black body radiation. (01mark)

The total energy radiated by a black body per unit area of the surface per unit time is proportional to the fourth power of the body's absolute temperature.

- (ii) The average distance of Pluto from the sun is about 40 times that of the Earth from the sun. If the sun radiated as a black body at 600K, and is 1.5×10^{11} m from the Earth, Calculate the temperature of Pluto. (06marks)

$$\text{Power radiated by the sun} = 4\pi r_s^2 \sigma T_s^4$$

$$\text{Power radiated by Pluto} = \frac{\pi r_p^2}{4\pi R^2} \times 4\pi r_s^2 \sigma T_s^4$$

$$\text{Power radiated by Pluto assuming it is a black body} = 4\pi r_p^2 \sigma T_p^4$$

$$\text{At equilibrium, } 4\pi r_p^2 \sigma T_p^4 = \frac{\pi r_p^2}{4\pi R^2} \times 4\pi r_s^2 \sigma T_s^4$$

$$T_p = \left(\frac{T_s^4 r_s^2}{4R^2} \right)^{\frac{1}{4}} = \left(\frac{6000^4 \times (7 \times 10^8)^2}{4 \times (40 \times 1.5 \times 10^{11})^2} \right)^{\frac{1}{4}} = 45.8\text{K}$$

52. (a)(i) What is meant by term fixed point in thermometry? Give two examples (02marks)

Fixed points are temperatures at which water changes from one phase to the other, i.e. melting and boiling points.

- (ii) How is temperature on Celsius scale defined on a platinum resistance thermometer? (02marks)

$$\theta = \frac{R_\theta - R_0}{R_{100} - R_0} \text{ where } R_\theta \text{ is the resistance at unknown temperature, } R_0 \text{ and } R_{100} \text{ are resistances at ice and steam points respectively}$$

- (b) Explain the extent to which two thermometers based on different properties but calibrated using the same fixed points are likely to agree when used to measure temperature.

- (i) near one of the fixed point (02marks)

They do not agree since different thermometric properties vary differently with temperature changes

- (ii) mid-way between two fixed points (02marks)

They agree because the choice of fixed points is definite.

- (c) The continuous flow method is used in determination of the specific heat capacity of liquids.

- (i) What are the principal advantages of this method compared to the method of mixtures? (03marks)

- The heat capacity of the apparatus is not required in the apparatus
- Heat losses are not required in the calculation
- Temperatures read at leisure.

(ii) In such a method, 50g of water is collected in 1 minute. The voltmeter and ammeter readings are 12.0V and 2.50A respectively, while the inflow and outflow temperatures are 20°C and 28°C respectively. When the flow rate is reduced to 25g min⁻¹, the voltmeter and ammeter read 8.8V and 1.85A respectively while the temperatures remain constant. Calculate the specific heat capacity of water. (05marks)

From $VIt = mc\theta + h$

$$12 \times 2.5 \times 1 \times 60 = 50 \times 10^{-3} \times c \times (28 - 20) + h \dots\dots\dots (i)$$

$$8.8 \times 1.85 \times 1 \times 10 = 25 \times 10^{-3} \times c \times (28 - 20) + h \dots\dots\dots (ii)$$

Subtracting (ii) from (i)

$$c = 4.1 \times 10^3 \text{ J kg}^{-1} \text{ K}^{-1}$$

(d) What are the advantages of a thermocouple over a constant volume thermometer for measuring temperature? (04marks)

- Use to measure rapidly changing temperature
- It can give direct readings
- It is not bulky
- It can measure temperature at a point

53. (a)(i) What is meant by isothermal and adiabatic changes? (02marks)

Isothermal expansion takes place at constant temperature.

Adiabatic expansion takes place at constant heat.

(ii) Using same axes and point, sketch graphs of pressure versus volume for fixed mass of a gas undergoing isothermal and adiabatic changes. (03marks)

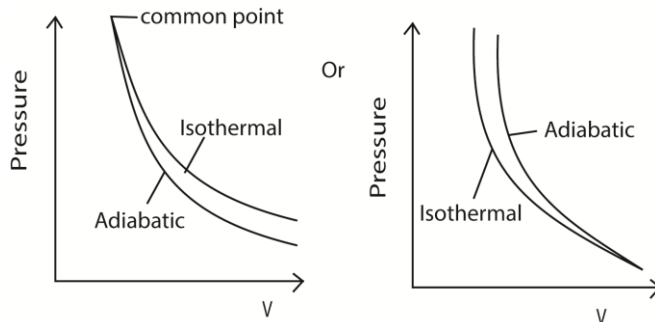

(b) An ideal gas is trapped in a cylinder by a movable piston. Initially it occupies a volume of $8 \times 10^{-3} \text{ m}^3$ and exerts a pressure of 108kPa. The gas undergoes an isothermal expansion until its volume is $27 \times 10^{-3} \text{ m}^3$. It is then compressed adiabatically to the original volume of the gas.

(i) Calculate the final pressure of the gas (06marks)

Under isothermal, $P_1V_1 = P_2V_2$

$$108 \times 10^3 \times 8 \times 10^{-3} = P_2 \times 27 \times 10^{-3}$$

$$P_2 = 3.2 \times 10^3 \text{ Pa}$$

Under adiabatic, $P_3V_3^\gamma = P_2V_2^\gamma$

$$P_3(8 \times 10^{-3})^{\frac{5}{3}} = 3.2 \times 10^3 \times (27 \times 10^{-3})^{\frac{5}{3}}$$

$$P_3 = 243 \times 10^3 \text{ Pa}$$

(iii) Sketch and label the two stages on a p-v diagram. (02marks)

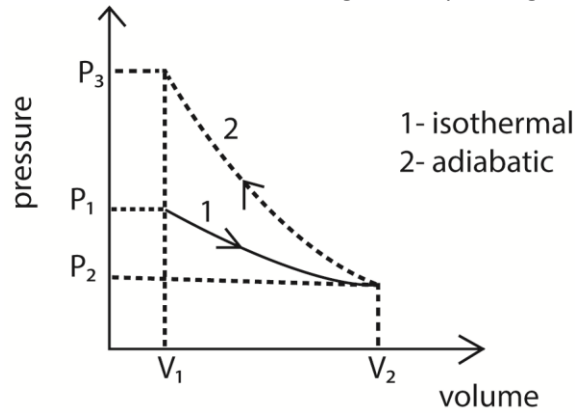

[The ratio of the principal molar heat capacities of the gas = 5:3]

(c) (i) Define molar heat capacities at constant pressure. (01mark)

The specific heat capacity of a gas at constant pressure is the heat required to warm unit mass of it by one degree, when its pressure is kept constant.

(ii) Derive the expression $C_p - C_v = R$, for 1mole of a gas (05marks)

From $dQ = dU + dW$ (i)

But $dQ = C_p dT$, $dU = C_v dT$ and $dW = PdV = RdT$

Substituting in (i)

$$C_p dT = C_v dT + RdT$$

$$\therefore C_p - C_v = R$$

(iii) In which ways does a real gas differ from an ideal gas? (02marks)

Real gas	Ideal gas
Intermolecular force are appreciable	Intermolecular forces are negligible
Volume of molecules compared to the volume of the container is not negligible	Volume of molecules compared to the volume of container is negligible
Obey Boyle's law at high temperature and very low pressure	Obey Boyle's law at all temperatures and pressures.

54. (a) (i) Define thermal conductivity. (01mark)

Thermal conductivity is the rate of heat flow per unit cross section area per unit temperature gradient.

(ii) State two factors which determine the rate of heat transfer through a material (02marks)

- Temperature gradient
- Thermal conductivity of a material
- Cross section area.

(b)(i) Describe with the aid of a diagram an experiment to measure the thermal conductivity of glass. (08marks)

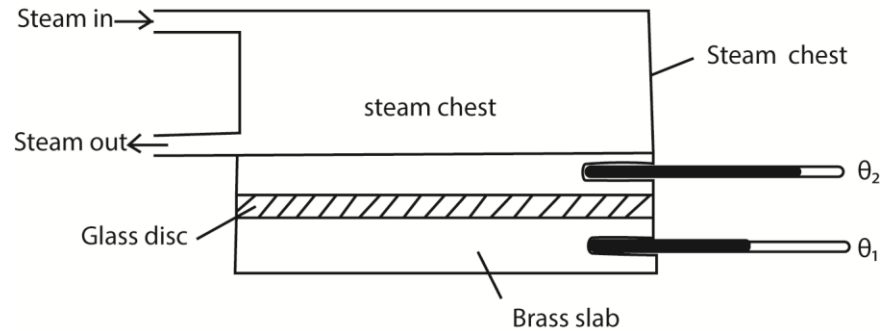

- Glass is cut in form of a thin disc of cross section area, A and thickness, x .
- The disc is sandwiched between a steam chest and brass slab of mass, m and specific heat capacity, c .
- Steam is passed through the chest until the thermometers register steady temperatures, θ_1 and θ_2 .
- Then, $\frac{\theta}{t} = kA \left(\frac{\theta_2 - \theta_1}{x} \right)$
- The glass disc is removed and brass slab is heated directly by steam chest, until its temperature is about 10°C above θ_1 .
- Steam chest is removed and the top of the glass slab is covered by the glass disc.
- The temperature of the slab is recorded at suitable time interval until its temperature is about 10°C below θ_1 .
- A graph of temperature against time is plotted and its slope s determined at θ_1

$$\frac{\theta}{t} = mcs$$

$$\therefore kA \left(\frac{\theta_2 - \theta_1}{x} \right) = mcs$$

$$k = \frac{mcsx}{A(\theta_2 - \theta_1)} \text{ but } A = \frac{\pi D^2}{4}$$

$$\therefore k = \frac{4mcsx}{\pi D^2(\theta_2 - \theta_1)}$$

(ii) Briefly discuss the advantages of the apparatus in (b)(i). (02marks)

- Temperature read at steady state
- The heat capacity of the apparatus not required

(c) Metal rods of copper, brass are welded together to form Y shaped figure.

The cross-section area of each rod is 2cm^2 . The free end of copper rod are maintained at 100°C , while the free ends of brass and steel rods are maintained at 0°C . If there is no heat loss from the surfaces of the rods and the length of the rods are 0.46m , 0.13m and 0.12m respectively.

(i) Calculate the temperature of the junction (05marks)

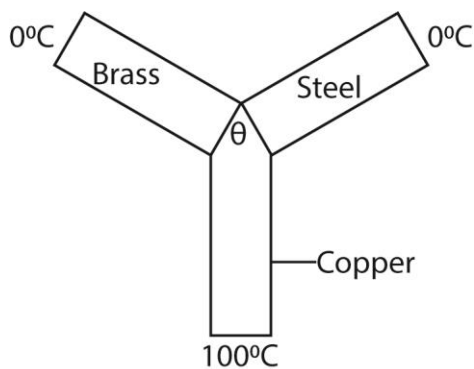

At the junction, $\frac{Q}{t} = kA \left(\frac{\theta_2 - \theta_1}{l} \right)$

$$\frac{dQ}{dt} = \frac{k_1 A}{l_1} (100 - \theta) = \frac{k_2 A}{l_2} (\theta - 0)$$

$$\frac{dQ}{dt} = \frac{k_1 A}{l_1} (100 - \theta) = \frac{k_3 A}{l_3} (\theta - 0)$$

Eqn. (i) and Eqn. (ii)

$$\frac{k_1 A}{l_1} (100 - \theta) = A \theta \left(\frac{k_2}{l_2} + \frac{k_3}{l_3} \right)^{-1}$$

$$\theta = \frac{200 k_1}{l_1} \left(\frac{2 k_1}{l_1} + \frac{k_2}{l_2} + \frac{k_3}{l_3} \right)^{-1} = \frac{200 \times 385}{0.46} \left(\frac{2 \times 385}{0.46} + \frac{109}{0.13} + \frac{50.2}{0.12} \right)^{-1} = 57.11^\circ\text{C}$$

(ii) Find the heat current in the copper rod. (02marks)

$$\frac{dQ}{dt} = \frac{kA}{l_1} (100 - \theta) = \frac{385 \times 10^{-4} (100 - 57.11)}{0.46} = 7.2 \text{Js}^{-1}$$

[Thermal conductivities of copper, brass and steel are $385 \text{Wm}^{-1}\text{K}^{-1}$, $109 \text{Wm}^{-1}\text{K}^{-1}$ and $50.2 \text{Wm}^{-1}\text{K}^{-1}$ respectively.]

55. (a) What is meant by:

(i) Thermometric property (01mark)

Thermometric property is a physical property that vary uniformly and continuously with temperature.

(ii) Triple point (01mark)

It the temperature and pressure at which a vapour, liquid and solid of a substance coexist at equilibrium.

(b) (i) Describe the steps taken to establish a temperature scale. (05marks)

- Choose a thermometric property
- Find its value, x_{100} at steam point and value x_0 at ice point.
- If the value of thermometric property is x_θ at temperature θ
- Then $\theta = \frac{x_\theta - x_0}{x_{100} - x_0}$

(ii) Explain why two thermometers may give different values for the same unknown temperature. (02marks)

Two thermometers based on different thermometric property may show different temperatures because thermometric properties vary differently with change in temperature.

- (c) (i) Describe, with the aid of a diagram, how a constant-volume gas thermometer may be used to measure temperature. (06mrks)

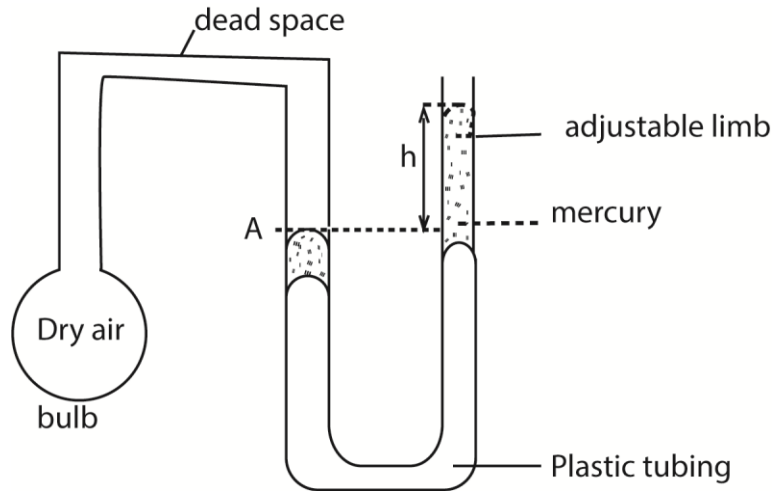

- Place the bulb inside whose temperature is to be measured.
- Allow some time for the gas to acquire the temperature of the enclosure. The gas in the bulb may expand and forces mercury up the adjustable tube.
- Adjust the adjustable limb to bring back mercury to constant volume at A and record the height of mercury, h_{θ} .
- The Celsius scale is given by $\theta = \left(\frac{h_{\theta} - h_0}{h_{100} - h_0} \right) \times 100^{\circ}C$ where h_{100} and h_0 are the heights at steam and ice points

- (ii) State three corrections that need to be made when using the thermometer in (c)(i) above. (03marks)

- The bulb should be made of glass with low thermal expansivity
- Dead space should be narrowed
- The bulb should be thin to allow easy penetration of heat

- (iii) State and explain the sources of inaccuracies in using mercury in glass thermometer, (02marks)

- Non uniformity the mercury tube
- Temperature of air in dead space being different from that in the bulb

56. (a) Define thermal conductivity of a material and state its units (02marks)

Thermal conductivity is the rate of heat flow per unit cross section area per unit temperature gradient. Units $Wm^{-1}K^{-1}$

- (b) Describe with the aid of a diagram how the thermal conductivity of a poor conductor can be determined. (07marks)

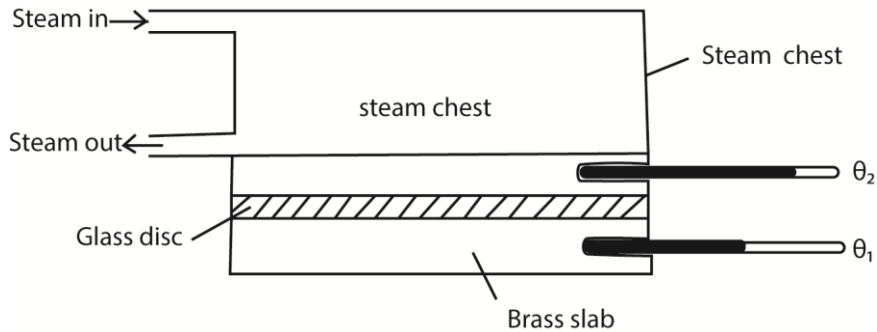

- Glass is cut in form of a thin disc of cross section area, A and thickness, x .
- The disc is sandwiched between a steam chest and brass slab of mass, m and specific heat capacity, c .
- Steam is passed through the chest until the thermometers register steady temperatures, θ_1 and θ_2 .
- Then, $\frac{\theta}{t} = kA \left(\frac{\theta_2 - \theta_1}{x} \right)$
- The glass disc is removed and brass slab is heated directly by steam chest, until its temperature is about 10°C above θ_1 .
- Steam chest is removed and the top of the glass slab is covered by the glass disc.
- The temperature of the slab is recorded at suitable time interval until its temperature is about 10°C below θ_1 .
- A graph of temperature against time is plotted and its slope s determined at θ_1

$$\frac{\theta}{t} = mcs$$

$$\therefore kA \left(\frac{\theta_2 - \theta_1}{x} \right) = mcs$$

$$k = \frac{mcsx}{A(\theta_2 - \theta_1)} \text{ but } A = \frac{\pi D^2}{4}$$

$$\therefore k = \frac{4mcsx}{\pi D^2(\theta_2 - \theta_1)}$$

- (c) A cooking saucepan made of iron has a base area of 0.05m^2 and thickness of 2.5mm . It has a thin layer of soot of average thickness 0.5mm on its bottom surface. Water in the saucepan is heated until it boils at 100°C . The water boils away at a rate of 0.60kg per minute and the side of the soot nearest to the heat source is at 150°C . Find the thermal conductivity of soot.

[Thermal conductivity of iron = $66\text{Wm}^{-1}\text{K}^{-1}$ and specific latent heat of vaporization = 2200kJ/kg]

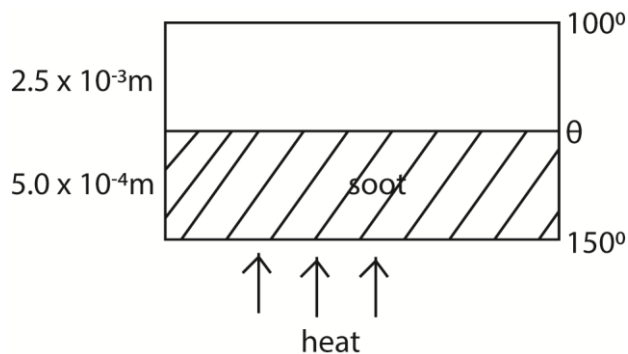

At steady state

$$\frac{dQ}{dt} = \frac{k_1 A (150 - \theta)}{l_1} = \frac{k_2 A (\theta - 100)}{l_2} = \frac{0.6}{60} \times 2.2 \times 10^6$$

$$\Rightarrow k_1 (150 - \theta) = k_2 (\theta - 100) \times \frac{l_1}{l_2} = k_1 (150 - \theta) = 66(\theta - 100) \times 0.2 \dots (i)$$

Also,

$$k_2 A (\theta - 100) = 2.2 \times 10^4 \times l_2$$

$$66 \times 0.05 (\theta - 100) = 2.2 \times 10^4 \times 2.5 \times 10^{-3}$$

$$\theta = 116.67^\circ\text{C}$$

Substituting θ in equation (ii)

$$k_1 (150 - 116.67) = 66(116.67 - 100) \times 0.2$$

$$k_1 = 6.6 \text{ Wm}^{-1}\text{K}^{-1}$$

Hence thermal conductivity of shoot = $6.6 \text{ Wm}^{-1}\text{K}^{-1}$

(d) (i) What is a black body? (01mark)

A black body is one that absorbs all the radiations falling on it, transmits and reflects none.

(ii) Sketch the spherical distribution of black body radiation for three different temperatures and describe their main features. (04marks)

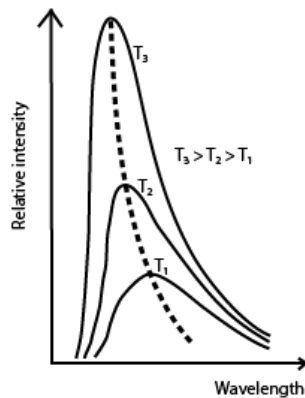

As temperature increases, the intensity increases. The intensity of shorter wavelengths increase more rapidly. The wavelength of the most intense radiation decreases as temperature increases.

57. (a) Derive the expression $P = \frac{1}{3} \rho c^2$ for the pressure, P , of an ideal gas of density ρ and mean square speed, c^2 . State any assumptions made (07marks)

Assumptions

- The intermolecular forces are negligible

- The volume of the gas is negligible compared the volume of the container
- Collision are perfectly elastic
- The duration of collision is negligible

Derivation

Consider a molecule of mass, m , moving in a cube of length, l and velocity, u .

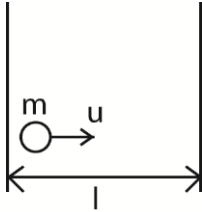

$$\text{Change in momentum} = mu - (-mu) = 2mu$$

$$\text{Rate of change of momentum} = \frac{2mu}{t}$$

$$\text{Time, } t, \text{ between collision} = \frac{2l}{u}$$

$$F_1 = 2mu \div \frac{2l}{u} = \frac{mu^2}{l}$$

For N molecules, force on the wall,

$$F = \frac{mu_1^2}{l} + \frac{mu_2^2}{l} + \frac{mu_3^2}{l} + \dots + \frac{mu_N^2}{l}$$

$$\text{Pressure, } P = \frac{F}{A} = \frac{m}{l^3} (u_1^2 + u_2^2 + u_3^2 + \dots + u_N^2) \text{ since } A = l^2$$

$$u^2 = \frac{u_1^2 + u_2^2 + u_3^2 + \dots + u_N^2}{N}$$

$$Nu^2 = u_1^2 + u_2^2 + u_3^2 + \dots + u_N^2$$

$$\therefore P = \frac{Nm u^2}{l^3} = \rho u^2; \text{ since } \rho = \frac{Nm}{l^3}$$

$$c^2 = u^2 + v^2 + w^2 \text{ and } u^2 = v^2 + w^2$$

$$\therefore c^2 = 3u^2 \Rightarrow u^2 = \frac{1}{3}c^2$$

$$\therefore P = \frac{1}{3}\rho c^2$$

(b) A gas is confined in a container of volume 0.1m^3 at a pressure of $1.0 \times 10^5\text{Nm}^{-2}$ and temperature of 300K . If the gas is assumed to be ideal, calculate the density of the gas.

(The relative molecular mass of the gas is 32) (05marks)

$$PV = nRT$$

$$n = \frac{1.0 \times 10^5 \times 0.1}{8.31 \times 300} = 4$$

mass of gas, $m = nM = 4 \times 32 \times 10^{-3} = 0.128\text{kg}$

Density = $\frac{m}{V} = \frac{0.128}{0.1} = 1.28\text{kgm}^{-3}$

(c) What is meant by

(i) isothermal change

Isothermal expansion takes place at constant temperature.

(ii) adiabatic change (02marks)

Adiabatic expansion takes place at constant heat.

(d) A gas at a pressure of $1.0 \times 10^6\text{Pa}$ is compressed adiabatically to half its volume and then allowed to expand isothermally to its original volume. Calculate the final pressure of the gas.

[Assume the ratio of the principal specific heat capacities $\frac{C_p}{C_v}, \gamma = 1.4$] (06marks)

For adiabatic change

$PV^\gamma = \text{constant}$

$\Rightarrow 1.0 \times 10^6 \times V^{1.4} = P \times \left(\frac{V}{2}\right)^{1.4}$

$P = 2.64 \times 10^6\text{Pa}$

For isothermal change

$PV = \text{constant}$

$2.64 \times 10^6 \times \frac{V}{2} = PV$

$P = 1.32 \times 10^6\text{Pa}$

58. (a) (i) Define molar heat capacity of a gas at constant volume. (01mark)

Molar heat capacity of a gas at constant volume is the amount of heat required to raise 1 mole of the gas through 1K at constant volume.

(ii) The specific heat capacity of oxygen at constant volume is $719\text{Jkg}^{-1}\text{K}^{-1}$. If the density of oxygen at s.t.p is 1.429kgm^{-3} , calculate the specific heat capacity of oxygen at constant pressure. (04marks)

$PV = nRT$

At s.t.p $1 \times 10^5 V = 273R$

$V = 273R \times 10^{-5}\text{m}^3$

Since $\rho = \frac{m}{V}$; $m = \rho V$ (i)

But $mC_p - mC_v = R$ (ii)

Where C_p and C_v are specific heat capacities at constant pressure and volume respectively

From equation (ii)

$C_p = \frac{R + mC_v}{m}$ (iii)

Substituting for m from equation (i) into equation (iii)

$$C_p = \frac{R + \rho(273R \times 10^{-5})C_v}{273\rho R \times 10^{-5}}$$

$$= \frac{1 + 273\rho C_v \times 10^{-5}}{273\rho \times 10^{-5}} = \frac{1 + (273 \times 1.429 \times 719 \times 10^{-5})}{273 \times 1.429 \times 10^{-5}} = 975.5\text{Jkg}^{-1}\text{K}^{-1}$$

(b) Indicate the different states of a real gas at different temperatures and pressure versus volume sketch graph.

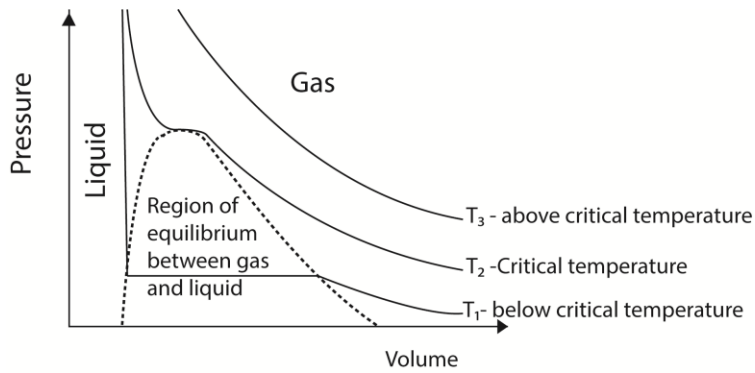

(c) (i) In deriving the expression $P = \frac{1}{3} \rho c^2$ for the pressure of an ideal gas, two of the assumptions made are not valid for a real gas. State these assumptions. (02marks)

- The intermolecular forces are negligible
- The volume of the gas is negligible compared the volume of the container
- Collision are perfectly elastic
- The duration of collision is negligible

(ii) The equation of state of one mole of a real gas is $\left(P + \frac{a}{v^2}\right)(v - b) = RT$

Account for the terms $\frac{a}{v^2}$ and b (02marks)

The molecules that strike the walls of the container are retarded by unbalances forces due to the molecules behind them. So the observed pressure is less than what it would be without these forces. Hence $\frac{a}{v^2}$ corrects deficit in pressure due to intermolecular attractions of gas molecules

The volume of the molecules compared to the volume of the container occupied by the gas. Therefore, b, called the co-volume accounts for the finite volume of molecules themselves

(d) Use the expression $P = \frac{1}{3} \rho c^2$; for the pressure of an ideal gas to derive Dalton's law of partial pressures (04marks)

$$P = \frac{1}{3} N \frac{m}{V} c^2 = \frac{2}{3} N \left(\frac{1}{2} m c^2 \right)$$

$$\text{For gas 1, } P_1 V_1 = \frac{2}{3} N_1 \left(\frac{1}{2} m_1 c_1^2 \right)$$

$$\Rightarrow N_1 = \frac{3}{2} P_1 V_1 \cdot \frac{1}{K_1}$$

Similarly for gas 2

$$N_2 = \frac{3}{2} P_2 V_2 \cdot \frac{1}{K_2}$$

For a mixture of gases, $N = \frac{3}{2} P V \cdot \frac{1}{K}$; but $N = N_1 + N_2$

$$\frac{3}{2} P V \cdot \frac{1}{K} = \frac{3}{2} P_1 V_1 \cdot \frac{1}{K_1} + \frac{3}{2} P_2 V_2 \cdot \frac{1}{K_2}$$

Since temperature is constant, $K_1 = K_2 = K$

$$- PV = P_1 V_1 + P_2 V_2$$

$$- \text{But } V = V_1 = V_2$$

$$\therefore P = P_1 + P_2$$

(e) Explain, with the aid of a volume versus temperature sketch graph, what happens to a gas cooled at constant pressure from room temperature to zero Kelvin. (04marks)

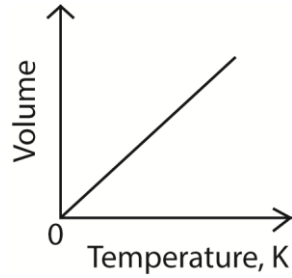

As the gas cools, the kinetic energy of its molecules reduce, implying that the internal energy of the molecules reduce until zero K where the volume is assumed to be zero and Charles laws ceases to apply.

59. (a) What is meant by black body? (01mark)

A black body is one that absorbs all incident radiation, but reflects and transmits none.

(b) Describe how an approximate black body can be realized in practice. (02marks)

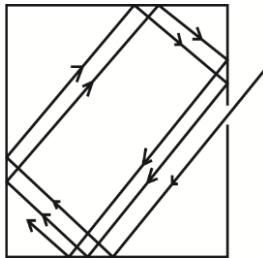

When radiation enters a black container through a hole, it undergoes multiple reflections. At each reflection, part of the radiation is absorbed. After several reflections, all the radiation is retained inside the container. Hence it approximates to a black body.

(c)(i) Draw sketch graphs to show how variation of relative intensity of black body radiation with wavelength for three different temperatures. (02marks)

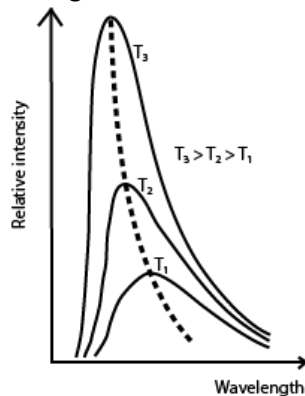

(ii) Describe the features of the sketch in (c)(i) above. (03marks)

As temperature increases, the intensity increases. The intensity of shorter wavelengths increase more rapidly. The wavelength of the most intense radiation decreases as temperature increases.

(d)(i) State Stefan's law (01mark)

Stefan's law states that the total power radiated by a black body is directly proportional to the fourth power of its absolute temperature.

(ii) A solid copper sphere of diameter 10 mm and temperature of 150K is placed in an enclosure maintained at a temperature of 290K. Calculate, stating assumptions made, the initial rate of rise of temperature of the sphere.

[Density of copper = $8.93 \times 10^3 \text{kgm}^{-3}$, specific heat capacity of copper = $3.7 \times 10^2 \text{JkgK}^{-1}$]

(07marks)

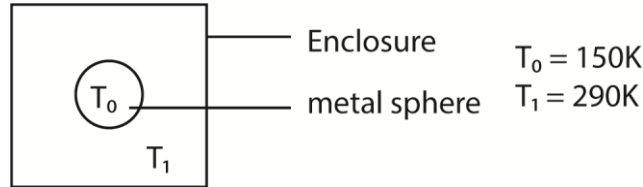

Power radiated by the sphere = $4\pi r^2 \sigma T_0^4$

Power absorbed by the sphere = $4\pi r^2 \sigma T_1^4$

Net power absorbed, $P = 4\pi r^2 \sigma (T_1^4 - T_0^4)$

But also, $P = mc \frac{d\theta}{dt} = \frac{4}{3} \pi r^3 \rho c \frac{d\theta}{dt}$

At equilibrium

$$\frac{4}{3} \pi r^3 \rho c \frac{d\theta}{dt} = 4\pi r^2 \sigma (T_1^4 - T_0^4)$$

$$\frac{d\theta}{dt} = \frac{3\sigma}{\rho cr} (T_1^4 - T_0^4) = \frac{3 \times 5.67 \times 10^{-8}}{8.93 \times 10^3 \times 3.7 \times 10^2 \times 5 \times 10^{-3}} = 0.068 \text{Ks}^{-1}$$

(e) With the aid of a labelled diagram, describe how a thermopile can be used to determine infrared radiation. (04marks)

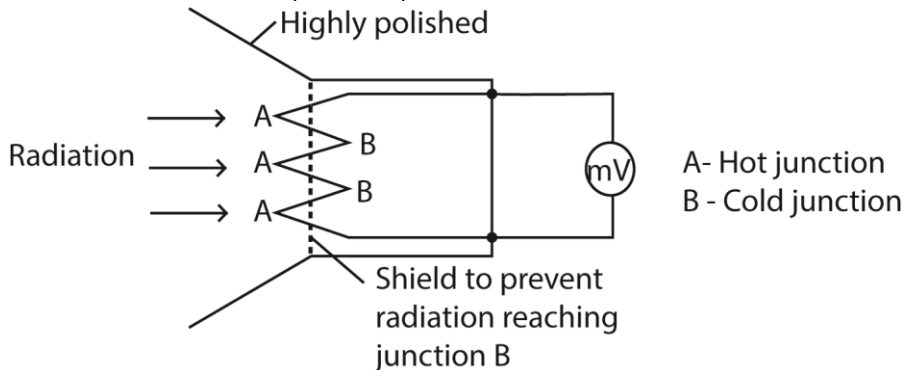

Radiation falling on junction A is absorbed and temperature rises above that of junction B. An e.m.f is generated and is measured by millivolt meter which deflects as a result.

60. (a) (i) What is meant by kinetic theory of gases? (03marks)

Gases are composed of molecules which are in continuous random motion. The molecules collide elastically with one another and also with the walls of the container. When heat energy is supplied, their kinetic energy increases.

(ii) Define an ideal gas (01mark)

An ideal gas is one which exactly obeys Boyles law at all conditions

(iii) State and explain conditions under which real gases behave like ideal gases. (04mark)

At very high temperature, the intermolecular forces of attraction become negligible.

At low pressure, the volume of gas molecules become negligible compared to the volume of the container.

(b) (i) Describe an experiment to show that a liquid boils only when its saturated vapor pressure is equal to external pressure (05marks)

Experiment to show that a liquid boils off when its saturated vapour pressure equals the external pressure

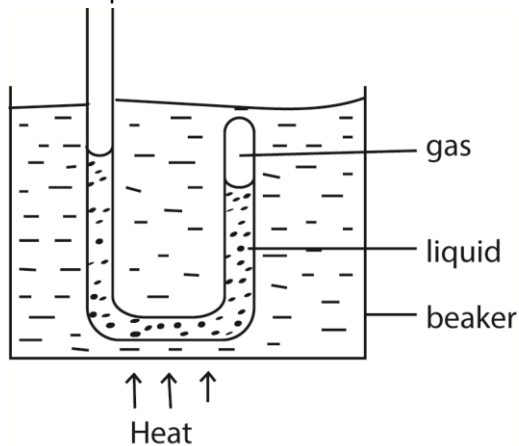

- Air is trapped in the closed limb of the tube by water column.
- The tube is heated in water bath.
- When the water bath begins to boil, the water in the tube comes to the same level in each limb.
- This shows that the vapor pressure in closed limb is equal to external pressure.

(ii) Explain how cooking at a pressure of 76cm of mercury and temperature of 100°C may be achieved on top of high mountains. (03marks)

Cooking pans are fitted with lids that possess safety valves that open when the pressure exceeds 76cmHg. During cooking the vapour pressure inside the cooking pan increase and the temperature increases to 100°C. The safety valves prevents pressure to exceed 76cmHg and therefore boiling occurs at 100°C.

(c) (i) Define root-mean-square speed of molecules of a gas. (01mark)

Root mean square speed of the gas is the average of the square speeds of individual molecules of a gas.

(ii) The mass of hydrogen and oxygen atoms are 1.66×10^{-27} kg and 2.66×10^{-26} kg respectively.

What is the ratio of the root mean square speed of hydrogen to that of oxygen molecules at the same temperature? (03marks)

From $\frac{1}{3}Nmc^2 = RT$

$$\frac{1}{3}N \times 1.66 \times 10^{-27} \times c_H^2 = \frac{1}{3}N \times 2.66 \times 10^{-26} \times c_O^2$$

$$\frac{c_H^2}{c_O^2} = \frac{2.66 \times 10^{-26}}{1.66 \times 10^{-27}} = 16$$

61. (a) State the assumption made in the derivation of the expression $P = \frac{1}{3}\rho c^2$ for pressure of an ideal gas (02marks)

- The intermolecular forces are negligible
- The volume of the gas is negligible compared the volume of the container
- Collision are perfectly elastic
- The duration of collision is negligible

(b) Use the expression in (a) above to deduce Dalton's law of partial pressures. (03marks)

$$P = \frac{1}{3}N \frac{m}{V} c^2 = \frac{2}{3}N \left(\frac{1}{2} m c^2 \right)$$

$$\text{For gas 1, } P_1 V_1 = \frac{2}{3} N_1 \left(\frac{1}{2} m_1 c_1^2 \right)$$

$$\Rightarrow N_1 = \frac{3}{2} P_1 V_1 \cdot \frac{1}{K_1}$$

Similarly for gas 2

$$N_2 = \frac{3}{2} P_2 V_2 \cdot \frac{1}{K_2}$$

For a mixture of gases, $N = \frac{3}{2} P V \cdot \frac{1}{K}$; but $N = N_1 + N_2$

$$\frac{3}{2} P V \cdot \frac{1}{K} = \frac{3}{2} P_1 V_1 \cdot \frac{1}{K_1} + \frac{3}{2} P_2 V_2 \cdot \frac{1}{K_2}$$

Since temperature is constant, $K_1 = K_2 = K$

- $PV = P_1 V_1 + P_2 V_2$
- But $V = V_1 = V_2$
- $\therefore P = P_1 + P_2$

(c) Describe an experiment to determine the saturation vapor pressure of a liquid. (06marks)

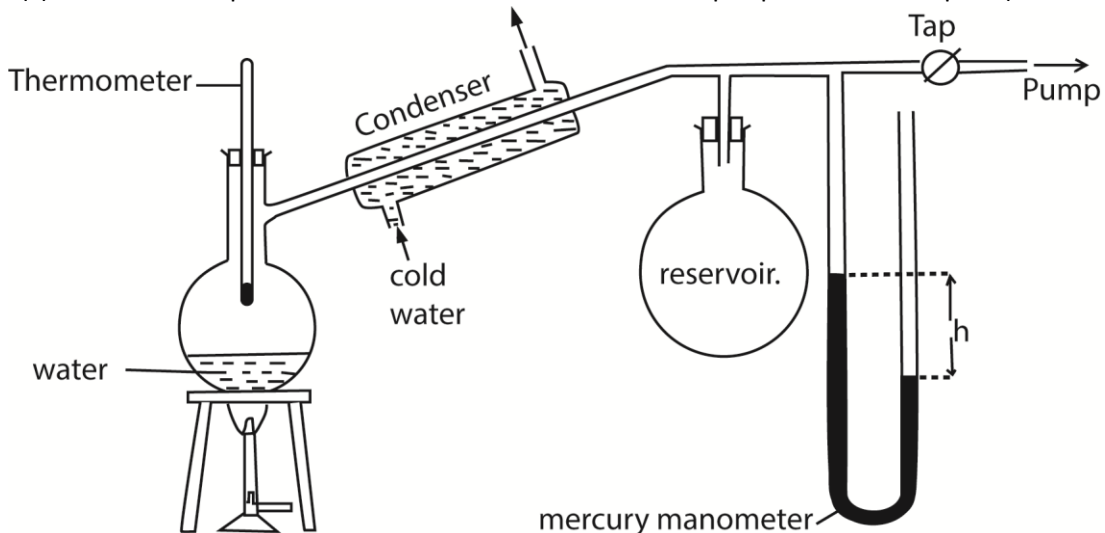

- The pressure of the air in R is shown by the mercury manometer; if its height is h, the pressure in mm mercury is $P = H - h$, where H is the barometer height.
- The tap is opened and the pressure above water varied using the pump to a suitable value.
- The tap is closed and water in the flask is heated until it boils.

- The temperature θ and difference in mercury levels, h , are noted and recorded.
- The saturated vapour pressure, $P = (H \pm h)$ is calculated
- The procedure is repeated other values of θ and h
- A graph of P versus θ is plotted and the saturated vapour pressure at a particular temperature is obtained.

(d) (i) What is meant by a reversible isothermal change? (02marks)

The change taking place at constant temperature and can be taken back from the final to initial states through exactly the same values of pressure and volume at every stage.

(ii) State the conditions for achieving a reversible isothermal change. (02marks)

Use vessels with thin good conducting walls having a frictionless piston, surrounded by constant temperature bath and the process must occur slowly.

(e) An ideal gas at 27°C and at a pressure of $1.01 \times 10^5 \text{Pa}$ is compressed reversibly and isothermally until its volume is halved. It is then expanded reversibly and adiabatically to twice its original volume. Calculate the final pressure and temperature of the gas if $\gamma=1.4$ (05marks)

For isothermal: $P_1 V_1 = P_2 V_2$; $P_2 = 2.02 \times 10^5 \text{Pa}$

For adiabatic; $2.02 \times 10^5 \left(\frac{V_1}{2}\right)^{1.4} = P_1 (2V_1)^{1.4}$; $P_1 = 2.9 \times 10^4 \text{Pa}$

Final pressure = $2.9 \times 10^4 \text{Pa}$

Also,

$TV^{\gamma-1} = \text{constant}$.

$$\Rightarrow (300.15) \left(\frac{V_1}{2}\right)^{0.4} = (2V_1)^{0.4}; T = 172\text{K}$$

62. (a) Explain the mechanism of heat conduction in solids. (03marks)

Atoms or molecules at the heated end vibrate more vigorously about their fixed positions. They collide and pass on heat to the neighboring atoms which in turn vibrate vigorously; collide and pass on heat to their neighboring atoms. In this way heat is transferred from the hot end to the cold end.

Also, good conductors have free electrons that acquired high kinetic energy when heat, move and transfer heat collide with atoms in the cold

(b) Describe a method of determining the thermal conductivity of cork in form of a thin sheet. (06marks)

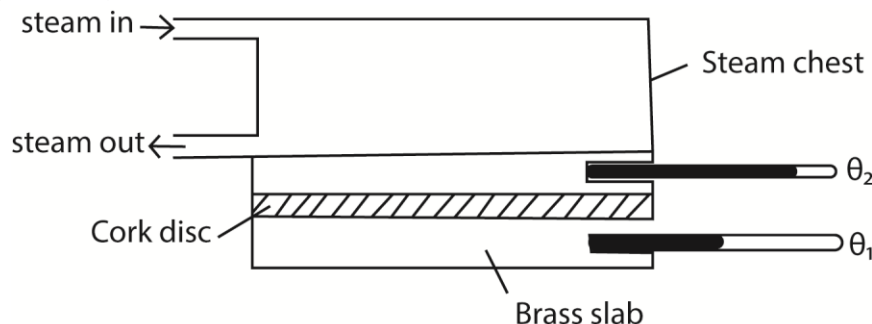

- Cook disc cut in form of a thin disc of cross section area, A and thickness, x.
- The disc is sandwiched between a steam chest and brass slab of mass, m and specific heat capacity, c.
- Steam is passed through the chest until the thermometers register steady temperatures, θ_1 and θ_2 .
- Then, $\frac{\theta}{t} = kA \left(\frac{\theta_2 - \theta_1}{x} \right)$
- The glass disc is removed and brass slab is heated directly by steam chest, until its temperature is about 10°C above θ_1 .
- Steam chest is removed and the top of the glass slab is covered by the glass disc.
- The temperature of the slab is recorded at suitable time interval until its temperature is about 10°C below θ_1 .
- A graph of temperature against time is plotted and its slope s determined at θ_1

$$\frac{\theta}{t} = mcs$$

$$\therefore kA \left(\frac{\theta_2 - \theta_1}{x} \right) = mcs$$

$$k = \frac{mcsx}{A(\theta_2 - \theta_1)} \text{ but } A = \frac{\pi D^2}{4}$$

$$\therefore k = \frac{4mcsx}{\pi D^2(\theta_2 - \theta_1)}$$

- (c) A window of height 1.0m and width 1.5m contains a double glazed unit consisting of two single glass panes, each of thickness 4.0mm separated by an air gap of 2.0mm. Calculate the rate at which heat is conducted through the window if the temperatures of external surfaces of glass are 20°C and 30°C respectively.

[Thermal conductivities of glass and air are $0.72\text{Wm}^{-1}\text{K}^{-1}$ and $0.025\text{Wm}^{-1}\text{K}^{-1}$ respectively]

(07marks)

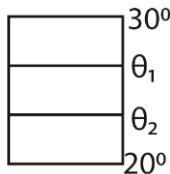

$$\frac{dQ}{dT} = \frac{kA(\theta_2 - \theta_1)}{L} = mc \times \text{slope}$$

$$\frac{k_1 A (30 - \theta_1)}{4 \times 10^{-3}} = \frac{k_2 A (\theta_2 - \theta_1)}{2 \times 10^{-3}} = \frac{k_1 A (\theta_1 - 20)}{4 \times 10^{-3}}$$

$$\Rightarrow \theta_1 + \theta_2 = 50$$

$$\frac{0.72A(30 - \theta_1)}{4 \times 10^{-3}} = \frac{0.025A(\theta_1 - \theta_2)}{2 \times 10^{-3}}$$

$$\frac{0.72A(30 - \theta_1)}{4 \times 10^{-3}} = \frac{0.025A(\theta_1 - (50 - \theta_1))}{2 \times 10^{-3}}$$

$$\theta_1 = 29.4^\circ\text{C}$$

$$\text{Hence } \frac{dQ}{dT} = \frac{0.72A(30 - 29.4)}{4 \times 10^{-3}} = 162\text{W}$$

(d) (i) State Stefan's law. (01mark)

Stefan's law states that the total energy radiated per square meter per second by a black body is directly proportional to the fourth power of its absolute temperature.

(ii) The element of a 1.0kW electric fire is 30.0cm long and 1.0cm in diameter. If the temperature of the surroundings is 20°C, estimate the working temperature of the element.

[Stefan's constant, $\sigma = 5.7 \times 10^{-8} \text{Wm}^{-2}\text{K}^{-4}$] (03marks)

$$P = A\sigma T^4$$

$$= 2\pi r l \sigma (T^4 - T_s^4)$$

$$= 2\pi r l \sigma T^4 - 2\pi r^2 l \sigma T_s^4$$

$$T = \sqrt[4]{\frac{1 \times 10^3 + 2\pi (0.5 \times 10^{-2})(30 \times 10^{-2}) \times 5.67 \times 10^{-8} \times 273^4}{2\pi (0.5 \times 10^{-2})(30 \times 10^{-2}) \times 5.67 \times 10^{-8}}} = 1169\text{K}$$

63. (a) (i) Define specific heat capacity of a substance (01mark)

Specific heat capacity is the quantity of heat required to raise the temperature of 1kg mass of a substance by 1K without change of state

(ii) State how heat losses are minimized in calorimetry (02mark)

- Surrounding the calorimeter vacuum
- Using a highly polished surface
- By lagging the calorimeter using insulating material
- Surrounding the calorimeter with a layer of still air.

(b) (i) What is meant by cooling correction? (01marks)

This is the extra temperature difference to be added to the observed maximum temperature of the mixture to make up for the heat lost to the surrounding during the experiment.

(ii) Explain how the cooling correction may be estimated in the determination of the heat capacity of poor by the method of mixtures (05marks)

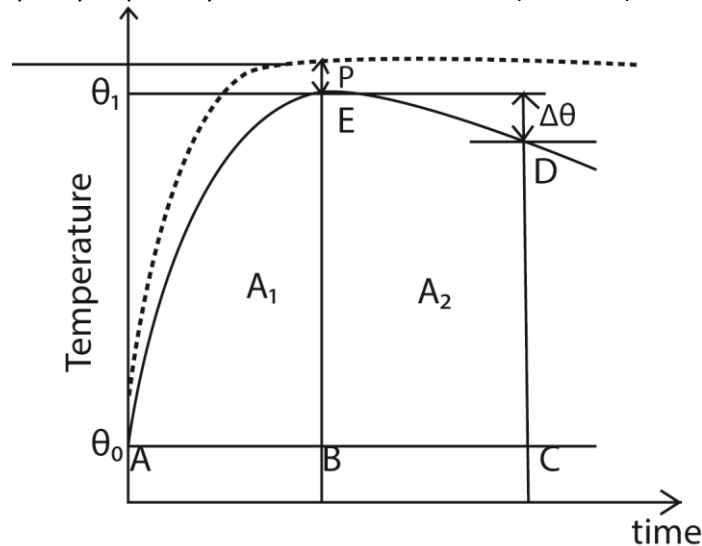

- The broken line shows how we would expect the temperature to rise if no heat were lost and the difference, P, between the plateau of this imaginary curve, and the crest of the experimental curve, E, is known as the 'cooling correction'

- Draw a line AC through θ_0 parallel to the time axis.
- Draw a line BE through θ_1 parallel to the temperature axis.
- Draw a line CD beyond BE parallel to the temperature axis and note $\Delta\theta$
- Estimate the area A_1 and A_2 under the graph by counting the square on the graph paper
- Cooling correction, P s given by the graph

$$\text{Cooling correction, } P = \frac{A_1}{A_2} \times \Delta\theta^\circ\text{C}$$

(iii) Explain why a small body cools faster than a larger one of the same material. (04marks)

Small body has a large surface area to volume ratio and small quantity of heat compare to the bod body. And the rate of heat is proportional to the surface area while the rate of temperature fall is inversely proportional to the quantity of heat held by the body

(c) Describe how you would determine the specific heat capacity of a liquid by the continuous flow method. (07marks)

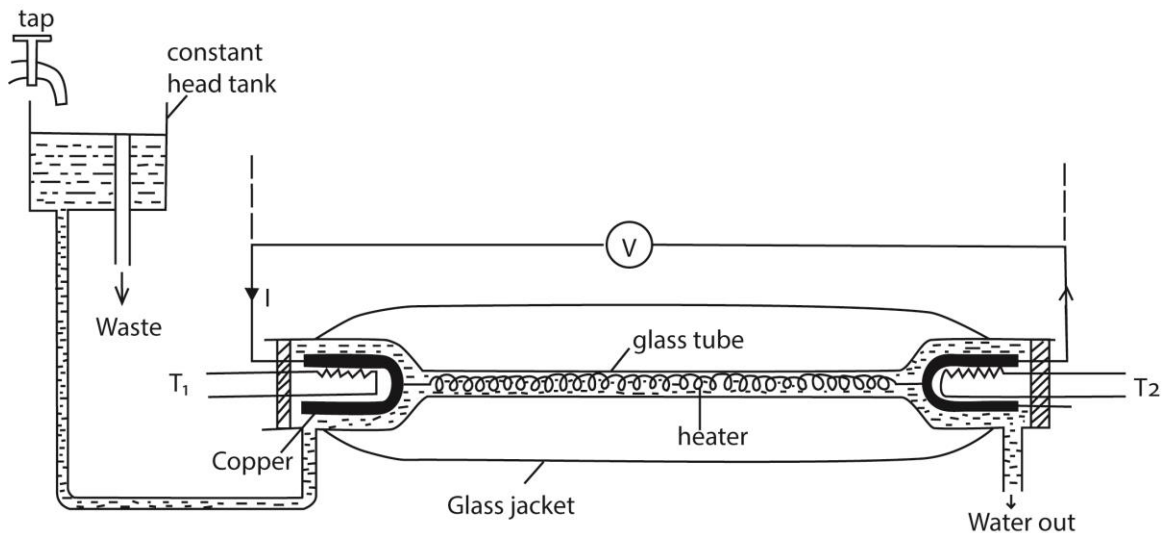

- A liquid is allowed to flow at constant rate
- Power is switched on and the liquid is heated until temperatures registered by T_1 and T_2 are steady and the values θ_1 and θ_2 respectively are recorded.
- The p.d V and current I are recorded from the voltmeter and ammeter respectively
- The mass, m of a liquid collected in time t is recorded
- At steady state; $VIt = mc(\theta_2 - \theta_1) + h$ (i)
- The rate of flow is changed and the voltage and current are adjusted until the steady readings of T_1 and T_2 are θ_1 and θ_2 respectively
- If m_1 , V_1 and I_1 are the values mass of liquid collected in time t, voltmeter and ammeter readings respectively, then

$$V_1 I_1 t = m_1 c (\theta_2 - \theta_1) + h \text{ (ii)}$$

Subtracting (ii) from (i)

$$c = \frac{(VI - V_1 I_1)t}{(m - m_1)(\theta - \theta_1)}$$

64. (a) Define thermal conductivity of a substance and state its units. (02marks)

Thermal conductivity is the rate of heat flow through a unit cross section area at per unit temperature gradient.

(b) Flux of solar energy incident on the earth's surface is $1.36 \times 10^3 \text{Wm}^{-2}$.

Calculate

(i) The temperature of the surface of the sun (04marks)

$$\frac{4\pi r_s^2 \sigma T_s^4}{4\pi R^2} = 1.36 \times 10^3$$

$$T_s = \sqrt[4]{\frac{1.36 \times 10^3 \times (1.5 \times 10^{11})^2}{(6.96 \times 10^8)^2 \times 5.67 \times 10^{-8}}} = 5777\text{K}$$

(ii) The total power emitted by the sun (03marks)

Power emitted by the sun = Power radiated by the sun

$$= A\sigma T_s^4$$

$$= 4\pi r_s^2 \sigma T_s^4$$

$$= 4\pi (6.96 \times 10^8)^2 \times 5.67 \times 10^{-8} \times 5777^4$$

$$= 3.85 \times 10^{26} \text{W}$$

(iii) The rate of loss of mass by the sun (03marks)

From $E = mc^2$

$$\frac{dm}{dt} = \frac{P}{c^2} = \frac{3.85 \times 10^{26}}{(3 \times 10^8)^2} = 4.3 \times 10^9 \text{kg s}^{-1}$$

(c)(i) Explain how heat is conducted through a glass rod. (03marks)

Atoms or molecules at the heated end vibrate more vigorously about their fixed positions. They collide and pass on heat to the neighboring atoms which in turn vibrate vigorously; collide and pass on heat to their neighboring atoms. In this way heat is transferred from the hot end to the cold end.

(ii) Why is a metal a better conductor of heat than glass? (02marks)

In addition to conduction of heat as in glass metal have free electrons that acquired high kinetic energy when heat, move and transfer heat collide with atoms in the cold

(iii) Explain briefly why it is necessary to use a thin specimen of large cross-section area in determining thermal conductivity of a poor conductor of heat. (03marks)

To ensure steep temperature gradient.

65. (a) (i) Explain what happens when a quantity of heat is applied to a fixed mass of a gas (02marks)

Heat supplied increase internal energy of the gas and used to overcome external pressure during the expansion.

(ii) Derive the relationship between the principal molar heat capacities C_p and C_v for an ideal gas. (05marks)

From $dQ = dU + dW$ (i)

But $dQ = C_p dT$, $dU = C_v dT$ and $dW = PdV = RdT$

Substituting in (i)
 $C_p dT = C_v dT + R dT$
 $\therefore C_p - C_v = R$

(b) (i) What is adiabatic process? (01mark)

An adiabatic process is one in which no heat is added or removed from the system.

(ii) A bicycle pump contains air at 290K. The piston of the pump is slowly pushed in until the volume of the air enclosed is one fifth of the total volume of the pump. The outlet is sealed off and the piston suddenly pulled out to full extension. If no air escapes, find its

temperature immediately after pulling the piston. $\left(\text{Take } C_p/C_v = 1.4 \right)$ (03marks)

$$T_2 V_2^{\gamma-1} = T_1 V_1^{\gamma-1}$$

$$T_2 = 290 \left(\frac{5V}{V} \right)^{0.4} = 152\text{K}$$

(c) (i) Distinguish between unsaturated and saturated vapors. (02marks)

Unsaturated vapour is a vapour that is not in dynamic equilibrium with its own liquid while saturated vapour is a vapour that is in dynamic equilibrium with its own liquid.

(ii) Draw graphs to show the relationship between pressure and temperature for ideal gas and for saturated water vapour originally at 0°C. (03marks)

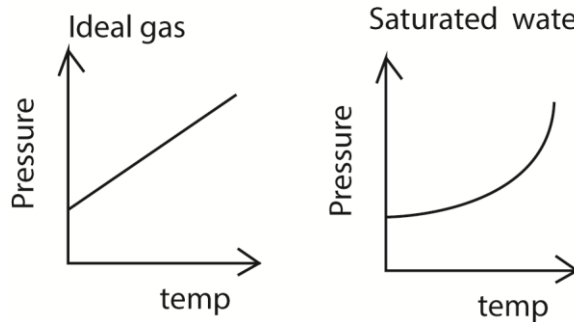

(d) In an experiment, the pressure of a fixed mass of air at constant temperature is 10.4kPa.

When the volume is halved, keeping the temperature constant, the pressure becomes 19.0kPa. Discuss the applicability of the above results in verifying Boyle's law. (04marks)

From $PV = \text{constant}$

Halving the volume at constant temperature doubles pressure. Since pressure was not doubled, Boyle's law is not verified.

66. (a) Explain why temperature remains constant during change of phase. (04marks)

The energy supplied goes into increasing the amplitude of oscillation of atoms which become so large that the regular arrangement of these atoms collapses. Until the process is complete, the temperature remains constant, hence no increase in temperature.

(b) Describe with the aid of labelled diagram, an electrical method for determination of specific latent heat of vaporization of a liquid. (07marks)

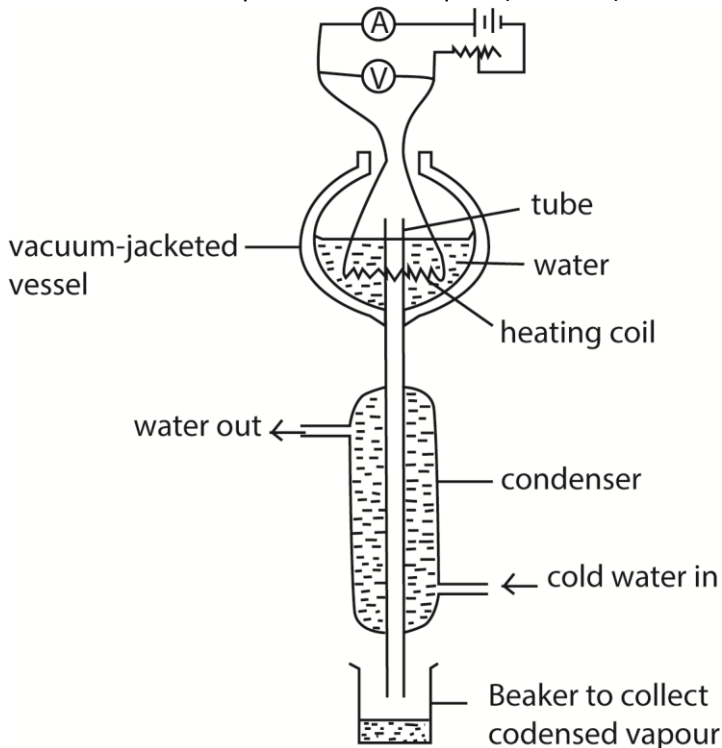

- Put the liquid whose specific latent heat of vaporization is required in a vacuum jacketed vessel as shown above.
- The liquid is heated to boiling point.
- The current, I , and voltage, V are recorded.
- The mass of condensed water, m , condensed in time, t , is determined.
- Then $IV = \frac{m}{t}L + h$, where h is the rate of heat loss to the surroundings
- To eliminate, h , the experiment is repeated for different values of I' and V' and the mass of the condensed water, m' condensed in time t is determined.
- Again $I'V' = \frac{m'}{t}L + h$

$$\text{Latent heat of vaporization, } L = \frac{(I'V' - IV)t}{(m' - m)}$$

(c) Water vapour and liquid water are confined in an air tight vessel. The temperature of the water is raised until all the water has evaporated. Draw a sketch graph to show how the pressure of water vapour changes with temperature and account for its main features. (06marks)

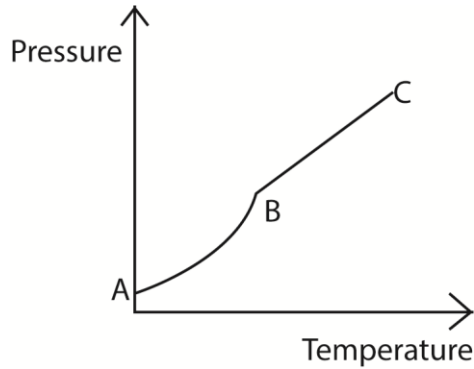

- Water vapor is saturated up to B; i.e. between A and B, increase in temperature increases the kinetic energy of the liquid molecules. The fastest molecules leave the liquid hence the liquid evaporates.
 - The density of the vapour above the liquid increases implying that saturated vapour pressure increases.
 - Beyond B, the unsaturated vapour obeys gas laws and hence the graph is linear.
- (d) Calculate the work done against the atmosphere when 1kg of water turns into vapour at atmospheric pressure of $1.01 \times 10^5 \text{ Pa}$.

[Density of water vapour = 0.598 kg m^{-3}] (03marks)

Work done = $Pdv = P(V_2 - V_1)$ where V_2 = volume of the vapor, V_1 = volume of water

$$\text{Volume} = \frac{\text{mass}}{\text{density}}$$

$$\therefore \text{Work done} = 1.01 \times 10^5 \left(\frac{1}{0.598} - \frac{1}{1000} \right) = 1.69 \times 10^5 \text{ J}$$

67. (a)(i) Describe Searle's method of determining the thermal conductivity of a good conductor of heat. (07marks)

Apparatus for thermal conductivity of a metal.

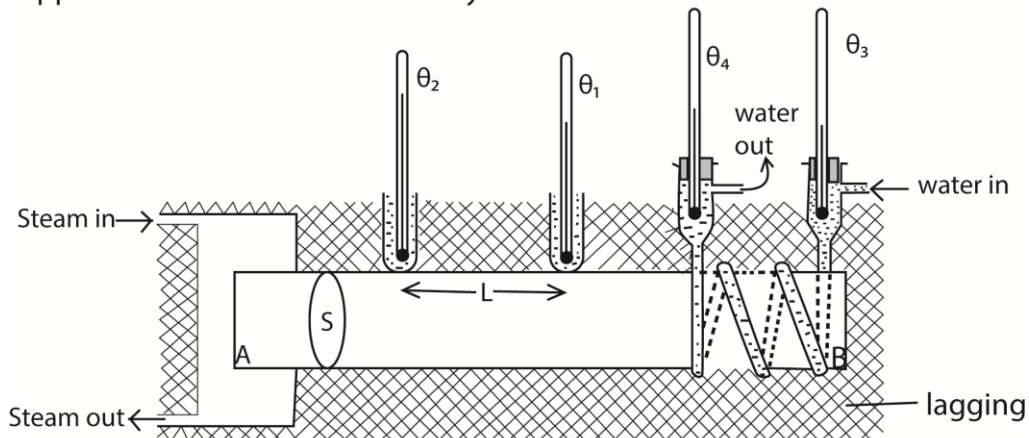

- Specimen bar AB of mean diameter, d , is heated by steam at end A and cooled by water at end B as shown above
- The lagging ensure a constant rate of heat flow

- The setup is left to run for some time until steady temperatures θ_1 , θ_2 , θ_3 and θ_4 are obtained.
- The rate water flow $m \text{ kgs}^{-1}$ is measured using a cylinder and stop clock.
- Cross section area $A = \frac{\pi d^2}{4}$
- The rate of heat flow is given by

$$\frac{Q}{t} = kA \left(\frac{\theta_2 - \theta_1}{L} \right) = mc_w(\theta_4 - \theta_3)$$
 where k = thermal conductivity of the metal and c_w is specific heat capacity of water

(ii) Why is the method in (a)(i) best suited for a good conductor of heat? (02marks)

- Rate of heat flow through the conductor is measurable
- There is a steep temperature gradient.

(b) The two ends of a metal bar of length 1.0m are perfectly lagged up to 20cm from either end. The ends of the bar maintained at 100°C and 0°C respectively.

(i) Sketch a graph of temperature versus distance of a bar. (02marks)

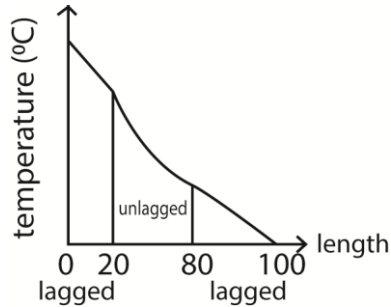

(ii) Explain the features of the graph in (b)(i) (03marks)

- In lagged portions there is constant heat flow because there is no heat loss to the surroundings
- In unlagged portion heat flow is not uniform due to heat loss to the environment.

68. (a) (i) State Boyle's law. (01mark)

The pressure of a fixed mass of a gas is inversely proportional to volume.

(ii) What is meant by partial pressure of a gas? (01 mark)

Partial pressure is the pressure that would be exerted by a gas if it alone occupied the volume of the mixture.

(iii)

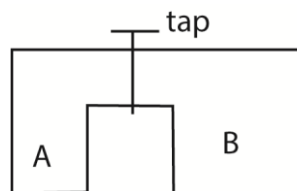

Two cylinders A and B of volumes V and $3V$ respectively are separately filled with a gas. The cylinders are connected as shown above with the tap closed. The pressures of A and B

are P and 4P respectively. When the tap is opened the common pressure becomes 60Pa. Assuming isothermal conditions find the value of P. (04marks)

Solution

From $PV = nRT$

$$\text{Moles } n_1 \text{ of the gas in A before mixing} = \frac{PV}{RT}$$

$$\text{Moles } n_2 \text{ of the gas in B before mixing} = \frac{4P \times 3V}{RT} = \frac{12PV}{RT}$$

$$\text{Moles } n_3 \text{ of the gas when tap is opened} = \frac{60 \times 4V}{RT}$$

But moles of the gas before mixing = mole of the gas after mixing

$$\begin{aligned} \Rightarrow n_1 + n_2 &= n_3 \\ \frac{PV}{RT} + \frac{12PV}{RT} &= \frac{60 \times 4V}{RT} \\ 13P &= 240 \\ P &= 18.46\text{Pa} \end{aligned}$$

(b) (i) State three differences between ideal and real gases. (03marks)

Real gas	Ideal gas
Intermolecular force are appreciable	Intermolecular forces are negligible
Volume of molecules compared to the volume of the container is not negligible	Volume of molecules compared to the volume of container is negligible
Obey Boyle's law at high temperature and very low pressure	Obey Boyle's law at all temperatures and pressures.

(ii) Sketch a pressure versus volume curve for a real gas undergoing compression below its critical temperature. (01mark)

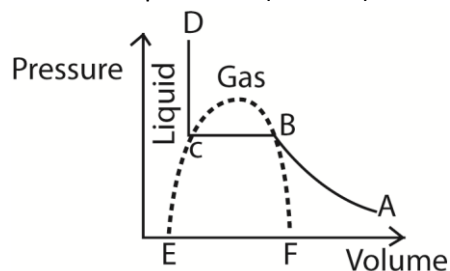

(iii) Explain the main features of the curve in (b)(ii) above (03marks)

- AB represents unsaturated vapour that approximately obey Boyle's law.
- BC represents saturated vapour, the gas turns into a liquid at constant pressure.
- CD is a liquid, small decrease in volume leads to a big increase in pressure because liquids are incompressible

(c) Two similar cylinders P and Q contain different gases at the same pressure. When gas is released from P the pressure remains constant for some time before it starts dropping. When gas is released from Q the pressure continuously drops. Explain the observation above. (05marks)

- The gas in P is in form of a saturated vapour; that is, in dynamic equilibrium with a liquid. As the gas is released, more liquid turns into a gas to restore pressure until the gas becomes unsaturated and the pressure begins to drop as the moles of the gas decrease
- The gas in Q is unsaturated, and thus pressure reduces as the moles of the gas reduces up on release.

(d) Using the expression for the kinetic pressure of an ideal gas, deduce the ideal gas equation of

$$\frac{1}{2}mc^2 = \frac{3}{2}K_B T \text{ (02marks)}$$

Given $\frac{1}{2}mc^2 = \frac{3}{2}K_B T$

From $P = \frac{1}{3}\rho c^2 = \frac{1}{3} \times \frac{M}{V} c^2$

$$PV = \frac{1}{3}Mc^2 = \left(\frac{1}{2}Mc^2\right) \times \frac{2}{3} = \frac{3}{2}K_B T \times \frac{2}{3} = K_B T = \text{Constant}$$

$\therefore PV = \text{constant}$

69. (a)(i) State the desirable properties of a material must have to be used as thermometric substance, (02marks)

- Should change considerably for a small change in temperature
- Should vary linearly and continuously with temperature.

(ii) Explain why scales of temperature based on different thermometric properties may not agree. (01marks)

Because different thermometric properties respond differently to temperature

(b) (i) Draw a labelled diagram to show a simple constant volume gas thermometer. (03marks)

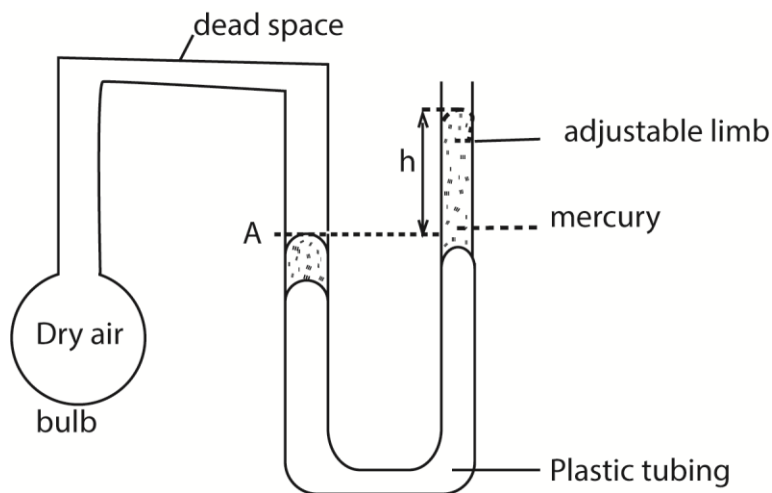

(ii) Describe how a simple constant volume gas thermometer can be used to establish a Celsius scale of temperature. (05marks)

- Place the bulb inside whose temperature is to be measured.
- Allow some time for the gas to acquire the temperature of the enclosure. The gas in the bulb may expand and forces mercury up the adjustable tube.
- Adjust the adjustable limb to bring back mercury to constant volume at A and record the height of mercury, h_{θ} .
- The Celsius scale is given by $\theta = \left(\frac{h_{\theta} - h_0}{h_{100} - h_0} \right) \times 100^{\circ}C$ where h_{100} and h_0 are the heights at steam and ice points

(iii) State the advantages and disadvantages of mercury in glass thermometer and constant-volume gas thermometer. (03marks)

Advantages of mercury in glass

- Give direct reading
- Cheap
- Portable

Disadvantage of mercury in glass

- Have limited temperature range
- Not very accurate

Advantages of constant volume gas thermometer

- Very sensitive to temperature change
- Has wide range
- Very accurate

Disadvantage of constant volume gas thermometer

- It is bulky
- Cannot measure temperature at a point
- Slow to respond to rapidly changing temperature
- Does not give direct readings

(c) The resistance of the element of platinum resistance thermometer is 4.00Ω at ice point and 5.46Ω at steam point. What is the temperature on the platinum resistance scale would correspond to a resistance of 9.84Ω . (03marks)

$$\theta = \frac{R_{\theta} - R_0}{R_{100} - R_0} \times 100^{\circ}C = \frac{9.84 - 4.0}{5.46 - 4.00} \times 100 = 400^{\circ}C$$

(d) The mean kinetic energy of one mole of helium gas at room temperature is $3.74 \times 10^3\text{J}$. Calculate room temperature.

$$\frac{1}{2}mc^2 = \frac{3}{2}K_B T$$

$$\text{Mean kinetic energy} = \frac{3}{2}K_B T$$

$$3.74 \times 10^3 = \frac{3}{2} \times 8.31 \times T$$

$$T = 300.04\text{K}$$

Thank you

Compiled by Dr. Bbosa Science