



Dr. Bosa Science

This document is sponsored by
The Science Foundation College Kiwanga- Namanve
 Uganda East Africa
 Senior one to senior six
 +256 778 633 682, 753 802709

Based on, best for sciences

1. (a) (i) What is an amplitude of a wave? (01mark)
 This is the maximum displacement of a wave particle in the wave from its equilibrium position.
- (ii) what is the difference between transverse and longitudinal waves? (01mark)
 Transverse waves are waves which propagate by vibrations perpendicular to the direction of travel of the wave while longitudinal waves are waves which propagate by vibrations which occur parallel to the direction of travel of the wave.
 Or
 Transverse waves propagate by formation of crests and trough while longitudinal waves propagate by formation of rarefactions and compressions.
- (b) Describe, with the aid of a diagram, an experiment to show how the fundamental frequency varies with tension in a given wire (06marks)

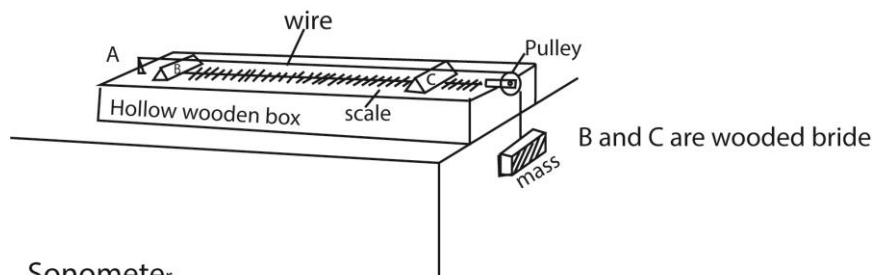

- The experiment is setup as shown above.
- The length L of the wire between B and C is fixed
- A suitable mass, m , is attached to the free end of the wire and the wire is plucked in the middle and a tuning fork of known frequency, f is sounded and held near the wire.
- The mass is varied until the vibrations of the wire resonate.
- The mass, m and corresponding frequency, f , are recorded in the table including the value of f^2 .
- The procedure is repeated with tuning forks of different frequencies.
- A graph of f^2 against m gives a straight line through the origin implying the $f^2 \propto m$.
- But $T = mg$ or $m = \frac{T}{g}$, hence, $f^2 \propto T$ or $f \propto \sqrt{T}$ since g is constant. Thus the fundamental frequency is proportional to the tension of the wire.

- (c) A glass tube open at the top, is held vertically and filled with water. A tuning fork vibrating at 264Hz, is held above the tube and water is allowed to flow out slowly. The first resonance occurs when the water level is 31.5cm from the top while the second resonance occurs when the water level is 96.3cm from top.

Find the;

- (i) Speed of sound in air. (04marks)

$$l_1 + c = \frac{\lambda}{4} \dots\dots\dots(i)$$

$$l_2 + c = \frac{2\lambda}{4} \dots\dots\dots(ii)$$

$$l_2 - l_1 = \frac{\lambda}{2}$$

$$\lambda = 2(l_2 - l_1)$$

But $v = f\lambda$

$$v = 2f(l_2 - l_1)$$

$$= 2 \times 264(0.963 - 0.315)$$

$$= 342\text{ms}^{-1}$$

- (ii) End correction. (02marks)

$$l_1 + c = \frac{v}{4f}$$

$$0.315 + c = \frac{342}{4 \times 264}$$

$$c = 0.009\text{m}$$

- (d) (i) What are beats? (01mark)

A beat is the periodic rise and drop in intensity of sound heard when two notes of nearly equal frequency are sounded together.

- (ii) Describe an experiment to determine the frequency of a note using beats. (05marks)

The test note is sounded together with a standard note of frequency, f_1 , the number, n , of loud sounds heard in a given time, t . The beat frequency, $f_b = \frac{n}{t}$. The frequency of the standard note is reduced slightly and experiment repeated. The new beat frequency f_b'

is determined. If $f_b' > f_b$, the frequency $f_2 = f_1 + f_b$. If $f_b' < f_b$, the frequency

$$f_2 = f_1 - f_b$$

Or

- A signal generator is sounded together with test note to produce beats.
- The frequency of the generator is adjusted such that the time between our sound increases.

- Further adjustment is done until it takes longer to hear the next boud sound (for sound to die out or fade)
- The frequency of the signal generator is recorded, and this is the frequency of of the test note.

2. (a) With the aid of a diagram, explain what happens when waves move from less dense to dense media. (03 marks)

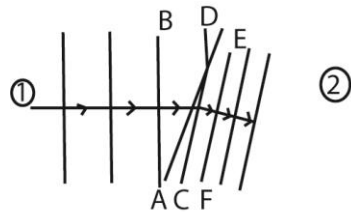

$$BD = v_1 t$$

$$AC = v_2 t$$

$$\therefore v_2 < v_1 \text{ and } AC < BD$$

The direction of travel of the wave changes, hence refraction.

Or

As the wave moves from medium ① into ② the wavelength reduces.

$$\Rightarrow DB > CF$$

Hence the new wave front gets inclined. Hence direction of the wave changes which is refraction.

(b) Use Huygens' construction to show that the refractive index, n , of medium is given by $n = \frac{c}{v}$ where c is the velocity of light in air, and v is the velocity of light in the medium. (05 marks)

Huygens construction

Consider a beam of parallel rays between LO and MD incident on the plane surface of the medium from air in the direction shown, and suppose that a plane wave front has reached the position OA at a certain instant; every point on OA acts as a secondary source of wavelets.

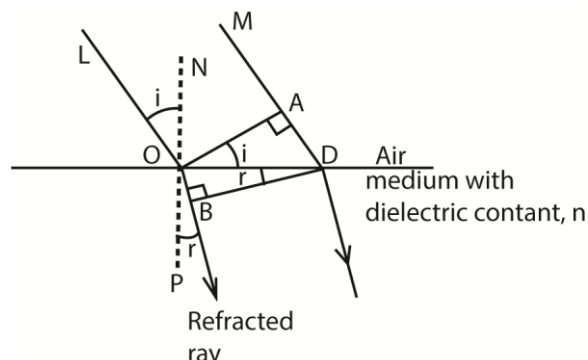

In time t , secondary wavelets from O travels a distance $OB = vt$ (where v = velocity of light in the medium).

In the same time, t , the secondary wavelength in air travels a distance $AD = ct$
 The tangent BD to the secondary wavelet is the new wavefront.

$$\sin i = \frac{AD}{OD} \text{ and } \sin r = \frac{OB}{OD}$$

From snell's law, $n = \frac{\sin i}{\sin r}$

$$= \frac{\frac{AD}{OD}}{\frac{OB}{OD}} = \frac{AD}{OB} = \frac{ct}{vt} = \frac{c}{v}$$

(c) (i) Explain how interference patterns are formed. (03 marks)

When two waves of equal frequency and equal wavelength (coherent sources) travel in the medium, they superpose where they meet in phase, reinforcement takes place resulting in a region of maximum intensity. Where they meet completely out of phase, cancellation takes place and a region minimum intensity form. Permanent alternate region of maximum and minimum intensity are therefore observed which is referred to as interference pattern.

(iii) Describe how the wavelength of light may be determined using Young's double slit experiment. (05 marks)

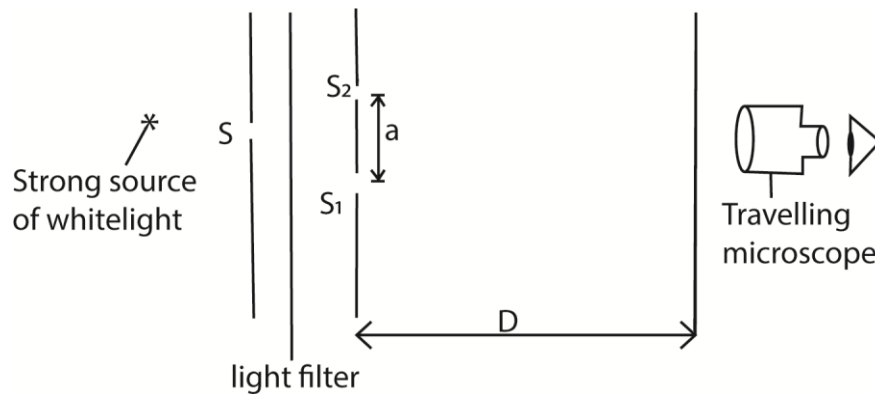

The set up is as shown above, where S , S_1 , and S_2 are narrow slits through which light diffracts forming interference fringes on a transparent screen. The position of the screen is adjusted until fringes are seen clearly. The number of fringes occupying a measured length along the screen is counted and the width y of a single fringe determined. The distance D , of the double slit from the screen is measured using a meter rule and the separation, a , of the double slit determined using a travelling microscope. The wavelength $\lambda = ay/D$

(d) A diffraction grating has 500 lines per mm and illuminated normally with monochromatic light of wavelength 589nm. Find the maximum number of diffraction image obtained. (04 marks)

$$d = \frac{1 \times 10^{-3}}{500}$$

$$n = \frac{d}{\lambda} = \frac{1 \times 10^{-3}}{500 \times 589 \times 10^{-9}} = 2.39$$

∴ the maximum order of diffraction = 3

3. (a) What is meant by interference pattern as applied to waves. (03marks)

When two sound waves meet they superpose. The interference pattern produced depends on the path difference.

If the path difference is a whole number, multiples of wavelength of wave, reinforcement takes place resulting into bright fringes. i.e. path difference, $\Delta = n\lambda$, $n = 0, 1, 2, \dots$

If the path difference is an odd number, multiple of half-wavelength, cancellation takes place resulting into regions of dark fringe; i.e. path difference, $\Delta = (2n+1)\frac{\lambda}{2}$, $n = 0, 1, 2, \dots$

If the sources are coherent, permanent alternative regions of bright and dark fringes are formed and are called interference pattern. Thus interference has occurred.

- (b) Explain why it is necessary to use a common source when demonstrating interference in light (03marks)

To produce observable fringes,

- The waves should have constant phase difference between them.
- The amplitude of the waves should also be equal or nearly equal

Since emission of light is always spontaneous; the above conditions are only possible if the source is the same.

- (c) In an experiment to determine wavelength of light using Young's method, two slits, a separation of 1.2mm were used. When the screen was placed 18.0cm from slits, 30 bright fringes occupying a distance 2.5mm was obtained,

- (i) Find wavelength of light used (04marks)

Slit separation, $a = 1.2 \times 10^{-3}\text{m}$

Number of bright fringes, $n = 30$

Distance from center of n th fringe, $x_n = 2.5 \times 10^{-3}\text{m}$

Distance from the slits to screen, $D = 18.0\text{cm} = 0.18\text{m}$

Using $x_n = \frac{n\lambda D}{a}$

$$2.5 \times 10^{-3} = \frac{30 \times \lambda \times 0.18}{1.2 \times 10^{-3}}; \lambda = 5.56 \times 10^{-7}\text{m}$$

- (ii) List the changes that would be observed if the distance of the screen from the slits was increased (02marks)

If the distance, D , of the screen from slits is increased, it follows from $y = \frac{\lambda D}{a}$ that the fringe separation, y , also increases, keeping wavelength, λ and slit separation, a constant.

Hence fringes occupy a bigger area on screen but their brightness reduce (become less distinct).

- (d)(i) Derive the expression for angular position of n^{th} order principal maximum produced by transmission diffraction grating.

Solution

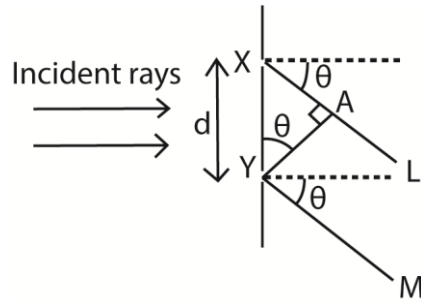

Suppose X and Y are corresponding points in consecutive slits where $XY = d$, and the grating is illuminated normally by monochromatic light of wavelength, λ , the direction, θ , the diffracted ray XL, and YM have path difference, XA

$$\text{From } \sin \theta = \frac{XA}{d}; \quad XA = d \sin \theta$$

The path difference for all corresponding points in the two slits have the same path difference, $d \sin \theta$. So other pairs of slits throughout the grating are treated the same way.

Also for bright or principle maxima to be obtained, the path difference = $n\lambda$.

$$\therefore d \sin \theta = n\lambda; \text{ where } d = \text{slit separation, } \lambda = \text{wavelength, } \theta = \text{angular momentum}$$

- (ii) Light of two wavelength $5.4 \times 10^{-7} \text{m}$ and $5.7 \times 10^{-7} \text{m}$ incident normally on transmission grating with spacing $2.00 \times 10^{-6} \text{m}$. Find the angular separation of second order principal maxima.

$$\lambda_1 = 5.4 \times 10^{-7} \text{m} \text{ and } \lambda_2 = 5.7 \times 10^{-7} \text{m, } d = 2.00 \times 10^{-6} \text{m}$$

$$\text{from } \sin \theta = \frac{n\lambda}{d}; \quad \theta = \sin^{-1}\left(\frac{n\lambda}{d}\right)$$

$$\theta_1 = \sin^{-1}\left(\frac{2 \times 5.4 \times 10^{-7}}{2 \times 10^{-6}}\right) = 0.54$$

$$\theta_2 = \sin^{-1}\left(\frac{2 \times 5.7 \times 10^{-7}}{2 \times 10^{-6}}\right) = 0.57$$

$$\text{Angular separation} = 0.57 - 0.54 = 0.03$$

- (iii) Suppose white light is used in (d)(ii) , describe the positions of the red and violet lights in the order principal maximum relative central maxima (01mark)

Violet will nearer to central maximum while red will be farther off.

4. (a) Define the following

- (i) Transverse waves

It is a wave in which the wave particles vibrate perpendicular to the direction of the wave motion

- (ii) Longitudinal waves

It is a wave in which the wave particles vibrate parallel to the direction of the wave motion.

(b) When a plane wave transverse a medium, the displacement of the particle is given by

$$y = 0.01\sin 2\pi(2t - 0.01x), \text{ where } y \text{ and } x \text{ are in meters and } t \text{ in seconds}$$

Calculate the

(i) Frequency of the wave (02marks)

$$\text{Form } y = A\sin 2\pi(\omega t - kx)$$

$$A = 0.01\text{m}, \omega = 2\pi(2), x = 2\pi(0.01)$$

Frequency, f , of a wave is given by $\omega = 2\pi f$

$$4\pi = 2\pi f$$

$$f = 2\text{Hz}$$

(ii) Wave velocity (03marks)

$$\text{From } k = \frac{2\pi}{\lambda}$$

$$0.02\pi = \frac{2\pi}{\lambda}$$

$$\lambda = 100\text{m}$$

$$v = f\lambda = 2 \times 100 = 200\text{ms}^{-1}$$

(iii) Phase difference at a given instant of time between two particles 50m apart. (02marks)

$$\text{Phase difference, } \phi = \frac{2\pi x}{\lambda} = \frac{2\pi \times 50}{100} = \pi$$

(c) Describe an experiment to determine the velocity of sound in air by an interference method. (06marks)

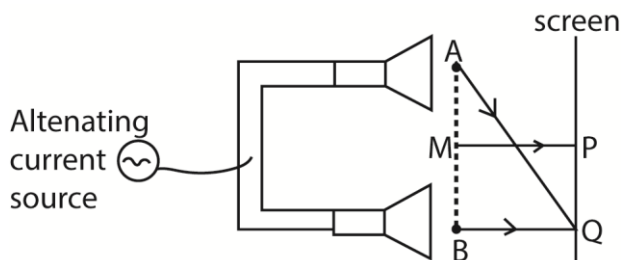

Two small loud speakers A and B about 1m apart are connected to the same oscillator so that both emit sound waves of frequency, f , in phase.

A sensitive detector is moved parallel to the line AB along PQ and it detects a maximum wave at P on perpendicular bisector MP of AB and another maximum wave when it first reaches a point Q directly opposite to B.

Constructive interference of sound wave occurs at P and Q, so the wavelength of sound wave is given by $\lambda = AQ - BQ$

The speed of sound in air is then calculated from $V = f\lambda$.

Alternative 1

A long tube is filled with water.

A vibrating tuning fork of known frequency f is held over the mouth of the tube.

Water is gradually removed until a loud sound is heard.

The length l_1 of air column is measured.

Water is allowed out until a loud sound is heard again.

The length l_2 of air column is measured

The velocity of sound in air is calculated from $V = 2f(l_2 - l_1)$

Alternative 2

(i) Along tube is filled with water.

(ii) A vibrating tuning fork of known frequency f is held over the mouth of the tube.

(iii) Water is gradually removed until a loud sound is heard.

(iv) The length L of air column is measured.

(v) (i) to (iv) is repeated with five other different tuning forks

(vi) The results are tabulated including values of $\frac{1}{f}$

(vii) A graph of L against $\frac{1}{f}$ is plotted and slope S is determined.

(viii) The speed of sound, $v = 4S$.

(d) (i) state two applications of Doppler effect. (02marks)

- Estimation of speed of distant objects like star and planets
- To detect objects moving in a circular track, for example a car negotiating a corner towards or away from an observer.
- Used in some types of radars to measure the velocity of detected objects, for example a motor car. The police use radar to detect speeding motorist as it approaches or recedes from a radar source
- In measurement of plasma temperature.

(ii) Derive an expression for frequency, f , of sound as heard by stationary observer when the source of sound of frequency, f , approaches with uniform speed, u_s (03marks)

Suppose c is the speed of sound in air, u_s is the speed of source, S , of sound, f is the frequency of source
If the source S were stationary, the f -wave sent out in 1s towards observer would cover a distance, V , and wavelength, $\lambda = \frac{c}{f}$

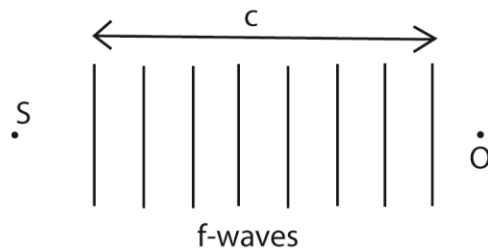

If the source is moving towards a stationary observer, O .

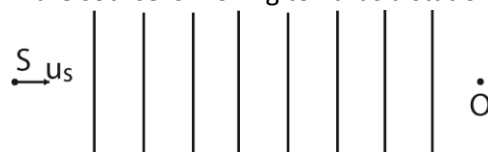

Where u_s is the speed of sound towards O. the sent wave occupy a shorter distance $(c-u_s)$ because S has moved a distance u_s , towards O in 1s. So the wave length λ' of waves reaching O is given by $\lambda' = \frac{c-u_s}{f}$

The speed of the waves relative to stationary observer is c.

Apparent frequency, f' ;

$$f' = \frac{\text{velocity of sound relative to O}}{\text{wavelength of the waves reaching O}} = \frac{c}{\lambda'}$$

$$f' = \frac{\frac{c}{c-u_s}}{\frac{1}{f}}$$

$$= \left(\frac{c}{c-u_s}\right) f$$

Since $(c-u_s)$ is less than c, the frequency tends to increase as source approaches observer.

5. (a) define the following as applied to wave motion

(i) Amplitude (01mark)

This is the maximum displacement of a wave particle from its equilibrium position.

(ii) Frequency (01mark)

This is the number of complete cycles per second.

(iii) Wavelength (01mark)

This is the distance between two successive wave particles that are in phase or the distance between two successive troughs or crests.

(iv) Derive the relationship between velocity, wavelength and frequency of a wave (03marks)

Consider a wave moving with speed, V. if in time T it covers a distance λ (one wave length)

Then distance = speed x time

$$\lambda = VT$$

$$\text{but } T = \frac{1}{f}$$

$$\text{then } V = \lambda f$$

(b) The displacement, y, of a progressive wave is given as $y = 2\cos \pi(t - \frac{x}{20})$; where x is horizontal distance in meters and t is time in seconds.

Determine the

(i) Velocity of the wave (03marks)

$$\text{Comparing with } y = A\cos 2\pi\left(\frac{t}{T} - \frac{x}{\lambda}\right)$$

$$\frac{2\pi t}{T} = \pi t$$

$$\frac{1}{T} = \frac{1}{2} = 0.5$$

$$\therefore f = 0.5\text{Hz}$$

$$\text{Also, } \frac{2\pi x}{\lambda} = \frac{\pi x}{\lambda}; \lambda = 40\text{m}$$

$$V = f\lambda = 40 \times 0.5 = 20\text{ms}^{-1}$$

(ii) Maximum velocity of particles of the medium. (02marks)

$$\text{Velocity of the particles} = \frac{dy}{dt} = -2\pi \sin \pi \left(t - \frac{x}{20} \right)$$

$$\text{Velocity is maximum when } \sin \pi \left(t - \frac{x}{20} \right) = 1$$

$$\therefore \text{maximum velocity} = |-2\pi| = 6.28 \text{ms}^{-1}$$

(c) (i) What is meant by the Doppler effect? (01marks)

It is the apparent change in frequency of a wave motion due to relative motion between the source and observer.

(ii) A source of sound moving with velocity, u , approaches an observer moving with velocity u_0 in the same direction. Derive the expression for frequency of sound heard by observer.

(05marks)



Let c be the velocity of sound from a source of frequency, f .

$$\text{Apparent wave length, } \lambda' = \frac{c-u}{f}$$

$$\text{Apparent velocity } c' = c - u_0$$

$$\therefore \text{Apparent frequency} = \frac{c'}{\lambda'} = \frac{(c-u_0)}{\frac{(c-u)}{f}} = \left(\frac{c-u_0}{c-u} \right) f$$

(d) Two whistles are sounded simultaneously. The wavelengths of the sounds emitted are 5.5m and 6.0m respectively. Find the beat frequency if the speed of sound is 330ms^{-1} .

$$\text{For 1}^{\text{st}} \text{ sound } f_1 = \frac{v}{\lambda_1} = \frac{330}{5.5} = 60 \text{Hz}$$

$$\text{For 2}^{\text{nd}} \text{ sound } f_2 = \frac{v}{\lambda_2} = \frac{330}{6} = 55 \text{Hz}$$

$$\text{Beat frequency } f_b = f_1 - f_2 = 60 - 55 = 5 \text{Hz}$$

6. (a) What is meant by the following as applied to light waves

(i) Diffraction (01mark)

It is the spreading of light around an obstacle in geometrical shadow leading to interference

(ii) Polarization (01mark)

It is a process by which vibration of light (electric vector) photons are restricted in one plane perpendicular to the direction of propagation of light.

(b) A diffraction grating of spacing d , is illuminated normally with light of wavelength, λ .

(i) Derive the condition for concurrence of diffraction maxima. (03marks)

Consider a parallel beam of monochromatic light incident on a grating of spacing d .

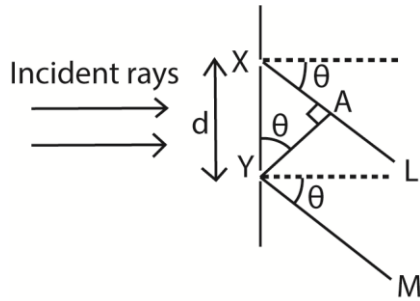

The path difference $XA = d \sin \theta$

For constructive interference, diffraction maxima occurs when the path difference is an integral multiple of wavelength, λ .

i.e. path difference = $n\lambda$

thus $d \sin \theta = n\lambda$ where $n = 0, 1, 2, 3, \dots$

- (ii) Describe briefly the intensity distribution on screen placed beyond the grating (02marks)

The central principle maxima is the most intense; the intensity decreases on the either side.

- (iii) What is the effect on diffraction pattern when grating with larger number of lines is used (02marks)

The diffraction maxima (image) becomes narrower and shaper

- (c) Light of wavelength $5.8 \times 10^{-7} \text{m}$ is incident on diffraction grating of 500 lines per mm. Find the

- (i) Diffraction angle for second order image (03marks)

$$d = \frac{l}{N} = \frac{1 \times 10^{-3}}{500} = 2 \times 10^{-6} \text{m}$$

from $d \sin \theta = n\lambda$

$$\sin \theta = \frac{n\lambda}{d} = \frac{2.0 \times 5.8 \times 10^{-7}}{2 \times 10^{-6}} = 0.58$$

$$\theta = 35.5^\circ$$

- (ii) Maximum number of images formed. (02marks)

$$d = n_{\max} \lambda$$

$$n_{\max} = \frac{d}{\lambda} = \frac{2 \times 10^{-6}}{5.8 \times 10^{-7}} = 3.4$$

$$\therefore n_{\max} = 3$$

- (d) (i) Describe how polarized light can be produced by reflection. (04marks)

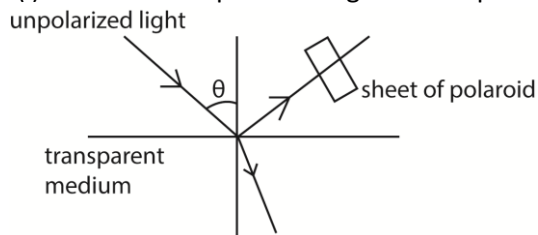

- Unpolarized light is made incident on a transparent medium at an angle θ .

- The reflected light is viewed through a sheet of polaroid while turning the sheet about an axis perpendicular to its plane
- The procedure is repeated for various angles of incidence until the reflected ray is cut off from object.
- At this particular angle θ , the reflected light is completely polarized.

(ii) List for used of polarized light.

- Measurement of sugar concentration
- Determination of stress distribution in materials like glass
- In film to give illusion of three dimension (orography)
- In liquid crystal display

7. (a) define the following as applied to a wave

(iii) Amplitude

This is the maximum displacement of a wave particle from its equilibrium position.

(iv) Wavelength (01mark)

This is the distance between two successive wave particles that are in phase or the distance between two successive troughs or crests.

(b)(i) State the conditions for the formation of standing wave (02marks)

- Two waves must be travelling in opposite direction.
- The waves must have the same speed, frequency and approximately the same amplitude

(ii) A string fixed at both ends is made to vibrate in different modes. If the frequencies of n^{th} harmonic and fundamental note are f_n and f_1 respectively. Show that $f_n = nf_1$.

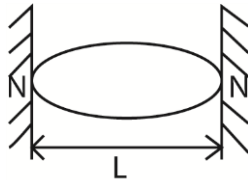

$$\frac{\lambda_1}{2} = L$$

$$\Rightarrow \lambda_1 = 2L$$

$$\Rightarrow v = f_1 \lambda_1$$

$$f_1 = \frac{v}{\lambda_1}$$

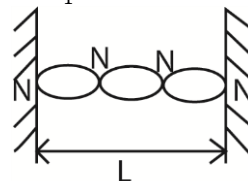

$$\frac{3\lambda_3}{2} = L$$

$$\Rightarrow \lambda_3 = \frac{2L}{3}$$

$$\Rightarrow V = f_3 \lambda_3$$

$$f_3 = \frac{V}{\lambda_3} = 3 \left(\frac{V}{2L} \right) = 3f_1$$

if the vibration produced n loops, then frequency, $f_n = nf_1$

- (c) The mass of a vibrating length of sonometer wire is 1.20g. a note of frequency 512Hz is produced when the wire is sounding in second overtone. If the tension in the wire is 100N. Calculate the vibrating length of the wire. (04marks)

$$f_n = \frac{n}{2l} \sqrt{\frac{T}{\mu}}$$

$$\text{But } \mu = \frac{1.2 \times 10^{-3}}{l}$$

$$512 = \frac{3}{2l} \sqrt{\frac{100l}{1.2 \times 10^{-3}}}; l = 1.987\text{m}$$

- (d) Explain why the quality of a note from an open pipe is preferred to that given by closed pipe (03marks)

Closed pipes give only odd harmonic while open pipes give both odd and even harmonic tones. The more overtone the better the quality of sound.

- (e) Describe an experiment to investigate the variation of frequency with length for vibrating wires (05marks)

A sonometer below is used

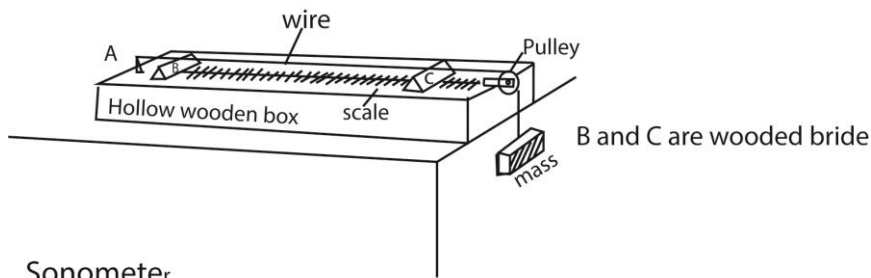

Sonometer

- The wooden bridges B and C vary the effective length of the wire, L.
- Constant tension in the wire is maintained by the fixed mass
- A paper rider is placed on the wire in the middle of BC and a sounding fork placed near it.
- The position of the bridge C is varied until sound is heard.
- The distance between the bridges L and the frequency, f , of the tuning fork is noted.
- The procedure is repeated for various tuning forks and values of L, f and $\frac{1}{L}$ are tabulated
- A plot of f against $\frac{1}{L}$ gives a straight line showing that the frequency of vibration of the wire is inversely proportional to length.

8. (a) Define an optical path (01mark)

This is the product of the refractive index of a medium and the geometrical path length.

Or

It is a length of a vacuum that contains the same number of waves as a given length in a medium.

- (b) With reference to Young's double slit experiment,

- (i) Explain how interference pattern is formed.

When two coherent waves travel in a medium, they meet and superimpose.

Where they meet in phase, constructive interference takes place and intensity is increased (or maximum)

Where they meet out of phase, cancellation takes place and intensity reduces (minimum)

Patterns of alternative regions of maximum and minimum intensities are formed that form interference pattern.

- (ii) State what happens to the fringes when the source of light is moved nearer to the slits.

The intensity of fringes increases

- (iii) state what happens to fringes when the separation of slits changes

Increase in separation of slits reduces fringe separation.

- (iv) describe the appearance of fringes when white light is used

When white light is used, colored fringes are observed. The central fringe is white, followed by blue and red fringes further off. Outwards the color overlap leading to white illumination

- (v) calculate the separation of the slits if the distance from slits to the screen is 800mm and the 8th bright fringe is formed 5mm from the center of the fringe system given that the wavelength of light is 6.2×10^{-7} m

$$y = \frac{n\Delta\lambda}{d}$$

$$d = \frac{n\Delta\lambda}{y} = \frac{8 \times 800 \times 10^{-3} \times 6.2 \times 10^{-7}}{5 \times 10^{-2}} = 7.94 \times 10^{-4} \text{ m}$$

- (c) An air wedge is formed by placing two glass slides of length 5.0cm in contact at one end and separated by a wire on the other end as shown below

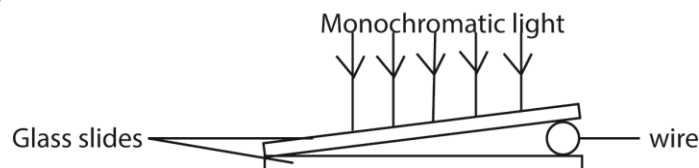

When the slides are illuminated with light of wavelength 500nm, 10 dark fringes are observed to occupy a distance of 2.5mm

- (i) Explain how the fringes are formed (03marks)

- Light is partly reflected and partly transmitted at the lower surface of the top slide.

- The transmitted light is partly reflected on the top of the lower slide.
- The two waves meet and superpose.
- Where the geometrical path difference is an integral multiple of a full wavelength, a dark fringe (band) is formed.
- Where the geometrical path difference is an odd multiple of half wavelength, a bright band is formed. This is because the wave reflected at the surface of the lower slide suffers a phase change of π (180°) equivalent to extra path of $\frac{\lambda}{2}$.

(ii) Determine the diameter of the wire(04marks)

Thickness, t

$$\Delta X = \frac{\lambda s}{2t}$$

$$t = \frac{\lambda s}{2\Delta X} = \frac{500 \times 10^{-9} \times 5 \times 10^{-2}}{2 \times 2.5 \times 10^{-3}} = 5 \times 10^{-5} \text{m}$$

9. (a) What is meant by the following as applied to waves

(v) Resonance

Resonance is said to occur when a body is vibrate at natural frequency due to impulses received from nearby source of the same frequency.

(vi) Frequency

Number of complete cycles made per second.

(b) Explain with the aid of a diagram the term fundamental note and overtone as applied to vibrating air in closed pipe.

When the air is brown into a pipe, it vibrates in many different modes, producing waves of different frequencies.

The note of lowest frequency is dominant one and is said to be the fundamental note.

A fundamental note is formed by a wave of large amplitude and with a node N at the closed end and an antinode A at the open end.

The other notes have frequencies higher than that of the fundamental note and are usually have low amplitudes and are less intense. They are called over notes.

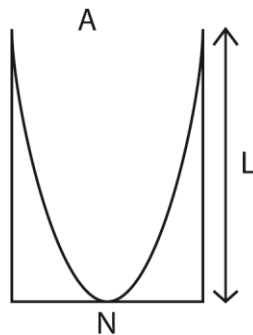

Fundamental note produced

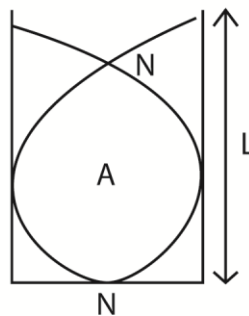

Overnotes produced

(c) Describe how you would determine the speed of sound in air using a resonance tube and several tuning forks.

Solution

- A glass tube which can be drained from bottom is filled with water.
- A sounding tuning fork of frequency f is brought to the mouth of the tube.
- The water is slowly drained until a

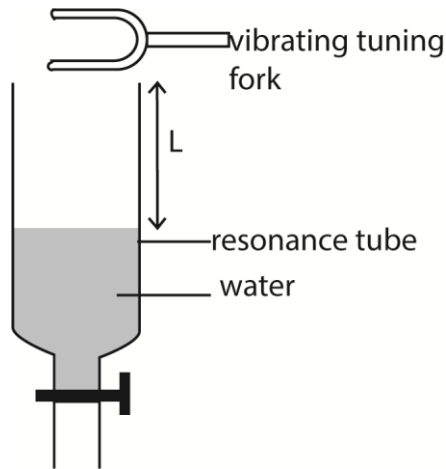

(d) (i) Explain the formation of beat.

When two notes of slightly different frequencies but similar amplitudes are sounded together, they superpose producing a note whose intensity increases and reduces periodically. This phenomenon is called beats.

(vii) Derive expression for beat frequency.

Consider two notes of frequencies f_1 and f_2 sounded together. Suppose the wave of frequency f_1 makes one cycle more than that of f_2 in time T_0 .

In time T , the number of waves of f_1 is f_1T

The number of waves of f_2 is f_2T

Therefore $f_1T - f_2T = 1$

$$f_1 - f_2 = \frac{1}{T}$$

$$\text{but } \frac{1}{T} = f$$

$$\therefore f_1 - f_2 = f, \text{ the beat frequency}$$

(b) Two observers A and B are provided with sources of sound of frequency 750Hz. If A remains stationary while B moves away at a velocity of 2.0ms^{-1} , find the number of beats heard per second by A. (Velocity of sound in air is 330ms^{-1})

Solution

A hears a note of frequency 750Hz due to its own source. He also hears a note of frequency, f' due to B.

$$\text{But } f' = \frac{v}{\lambda'} = \left(\frac{v}{v+u_s} \right) f \text{ where } \lambda' = \frac{v+u_s}{f}$$

$$f' = \frac{330}{330+2} \times 750 = 745.5\text{Hz}$$

$$\text{Beat frequency, } f = f_A - f = 750 - 745.5 = 4.5\text{Hz}$$

10. (a) What is meant by diffraction?

This is the spreading of light waves beyond their geometrical boundaries leading to interference.

(c) Explain using Huygens's principle the diffraction pattern produced by a single slit.

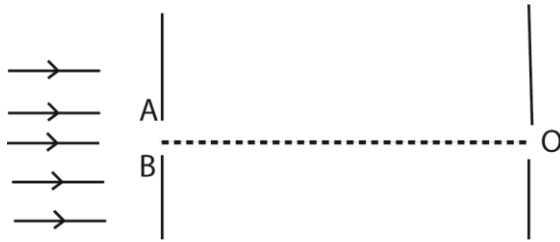

The diffraction patterns formed are due to superposition of secondary wavelets formed from the main wave front at AB

Each point on the wave front in the gap AB acts as a secondary source of wavelets that propagate in forward direction

At O, most of the wavelets arrive in phase causing constructive interference leading to formation of the central bright band.

On outwards from O, an increasing number of wavelets arrive out of phase and hence the bright bands reduces in intensity until a dark band is formed where all wavelets arrive out of phase.

As we move farther away from O parallel to AB, the intensity rises again to a much smaller maximum producing less bright band than at O.

More and more alternative bright and dark bands of reducing intensities are formed further from O parallel to AB where wavelets meet in phase and out of phase respectively.

The graph of intensity against distance is shown below.

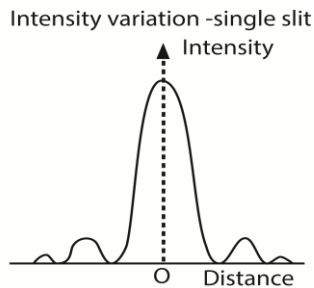

- (d) Light of wavelength $5.0 \times 10^{-7} \text{m}$ falls on a grating with 600 lines per mm, determine the highest order of diffraction that can be observed.

$$\lambda = 5.0 \times 10^{-6} \text{m}$$

$$\sin \theta = \frac{n\lambda}{d}; d = \frac{1}{600000} \text{m}^{-1}$$

$$l = 1 \times n \times 0.5 \times 10^{-6} \times 600000$$

$$n = \frac{1}{0.5 \times 10^{-6} \times 600000} = \frac{1}{3 \times 10^{-2}} = \frac{100}{30} = 3 \frac{1}{3}$$

- (e) (i) Explain what is meant by plane of polarized light?

A plane polarization of light is one in which the electric vector of polarized light varies or vibrates.

Plane polarized light is one whose electrical vectors varies in only one plane perpendicular to the direction of travel of the wave.

(ii) One application of polarized light.

Determination of concentration of glucose

(viii) A liquid of refractive index 1.3 is used to produce polarized light by reflection.

Calculate the angle of incidence of incidence on the liquid surface.

(e) (i) Describe how polarized light can be produced by reflection

Solution

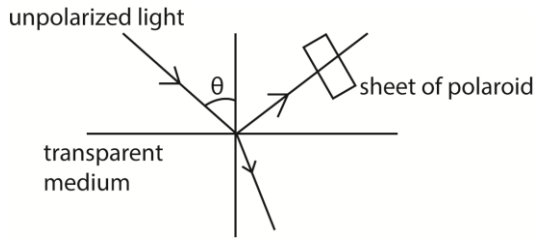

- A narrow beam of light is made incident on transparent medium.
- The reflected light is observed through a Polaroid.
- The angle of incidence is varied
- At each angle of incidence, the polaroid is rotated about the axis along the light incident on it
- At one angle of incidence, the light gets cut off the observer as the Polaroid is rotated.
- The reflected ray is now completely polarized.

(ii) State two uses of polarized light.

- Measurement of sugar concentration
- Determination of stress distribution in materials like glass
- In film to give illusion of three dimension (orography)
- In liquid crystal display

11. (a) Distinguish between progressive and stationary waves

Progressive waves	Stationary waves
(i) There is energy flow along the wave	(i) No energy flow
(ii) Vibrations have the same amplitudes and frequency	(ii) Amplitudes are different and depend on position along the wave
(iii) Phases of vibrations changes for different points along the wave	(iii) Some points are permanently fixed
(iv) Particles in phase are $n\lambda$ apart where $n = 1, 2, 3, \dots$	(iv) Particles at distance $\frac{3\lambda}{2}$ apart are in phase

(b)(i) What are overtones?

Overtone is a note of higher frequency produced by an instrument after fundamental (or main) notes.

- (iii) Explain why a music tone played on one instrument sound differently from the same note played on another instrument.
- When an instrument is played, all the allowed vibration take place producing different frequencies.
 - The quality of the musical note is determined by the number and strength (intensity) of the overtones.
 - Thus when the note played on an instrument has fewer overtones, it sounds different from the same note played on different instrument with more overtones.

(c) A stretched string of length L , is fixed at both ends and then set to vibrate in its allowed modes. Derive an expression for frequency of the second overtone in terms of fundamental frequency.

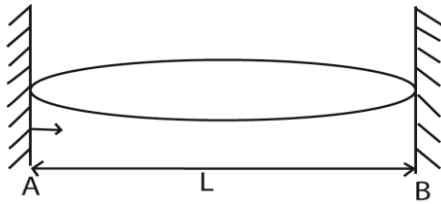

When the string is vibrating with fundamental frequency, the number of waves between A and B is $\frac{1}{2}$

$$L = \frac{1}{2} \lambda \text{ i.e. } \lambda = 2L$$

Let the velocity of the wave be v , then frequency of fundamental note, $f_0 = \frac{v}{\lambda} = \frac{v}{2L}$

When vibrating with 2nd overtone, the number of waves made by the length of the string between A and B is $\frac{3}{2} \lambda$.

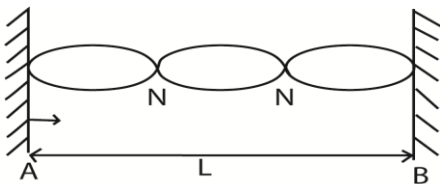

$$L = 2\lambda \text{ i.e. } \lambda = \frac{2}{3}L$$

$$\begin{aligned} \text{The } f_2 &= \frac{v}{\lambda} = \frac{v}{\frac{2}{3}L} \\ &= \frac{3v}{2L} = 3\left(\frac{v}{2L}\right) \end{aligned}$$

$$\therefore f_2 = 3f_0$$

(d) A wire of length 0.60m and mass 9×10^{-4} kg is under tension of 135N. The wire is plucked that it vibrates in its third harmonic. Calculate the frequency of the third harmonic.

$$\mu = \frac{m}{l} = \frac{9 \times 10^{-4}}{0.6} = 1.5 \times 10^{-3} \text{kgm}^{-1}$$

$$v = \sqrt{\frac{T}{\mu}} = \sqrt{\frac{135}{1.5 \times 10^{-3}}} = 300 \text{ms}^{-1}$$

The frequency of the third harmonic

$$f_2 = 3f_0 = \frac{2v}{2l} = \frac{2 \times 300}{2 \times 0.6} = 750 \text{Hz}$$

(e) Describe the variation of pressure with displacement of air in a closed pipe vibrating with fundamental frequency.

At the mouth, air is free to move and therefore the displacement of air molecules is large and the pressure is low. At the closed end, the molecules are less free and the displacement is minimal (or zero) and the pressure is high.

12. (a) What is meant by the following as applied to waves

(ix) Phase difference

It is the difference in phase angles of two waves at a given time. Or it is a difference in phase angles of two points in a wave.

(x) Optical path difference

It is $n_1x_1 - n_2x_2$, where n_1 and n_2 are refractive indices of media and x_1 and x_2 are the respective geometrical paths.

Or

It is the difference in the length of paths taken by two light waves from the source to the point of meeting.

Or

It is the difference in length of paths taken by two wave trains from coherent sources in the same time interval.

(b)(i) Explain how interference fringes are formed in an air wedge.

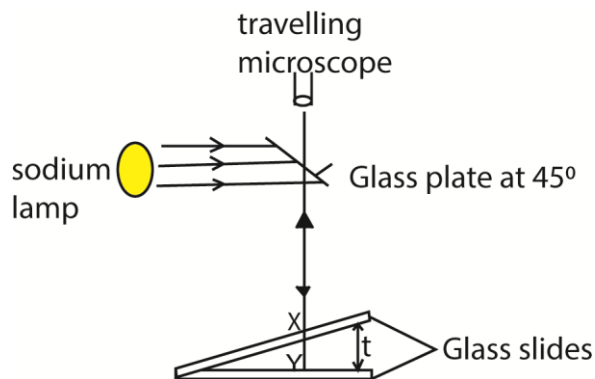

- Light from the lamp is reflected by the inclined glass plate so that it is incident on the wedge normally.
- On reaching X, some of the light is reflected at the bottom part of the top glass slide while part is transmitted and some is reflected at Y on the top part of the bottom glass slide.
- The two reflected waves are coherent and interfere.
- The wave reflected at X suffers no phase change while that from Y reflected from a boundary with a denser medium suffers a phase change of π due to reflection which is equivalent to an additional path of $\frac{\lambda}{2}$.
- Therefore a dark band is formed at the point of contact of the slide.
- Where the path difference is an integral multiple of wavelength, a bright band is formed; i.e. when $(2t = (m \pm \frac{1}{2}) \lambda$, where $m = 0, 1, 2, 3 \dots$ due to reinforcement.
- Where the path difference is an odd multiple of half the λ , a dark band is formed (i.e. $2t = m\lambda$); where $m = 0, 1, 2, 3, \dots$

- (ii) Two glass slides are separated by a thin wire to form an air wedge. When the wedge is illuminated normally by light of wavelength $5.6 \times 10^{-7} \text{ m}$, a total of 20 fringes occupying a distance of 15mm are obtained. Calculate the angle of the wedge.

$$\tan \phi = \frac{\lambda}{2y}; y = \frac{15}{20} \times 10^{-3} = 0.75 \times 10^{-3} \text{ m}$$

$$= \frac{5.6 \times 10^{-7}}{2 \times 0.75 \times 10^{-3}} = 5$$

$$\phi = 0.021^\circ$$

- (c) In Young's double slit experiment, 21 bright fringes occupying a distance of 3.6mm were visible on the screen. The distance of the screen from double slit was 29cm and the wavelength of the light used was $5.5 \times 10^{-7} \text{ m}$. Calculate the separation of the slit.

$$a = \frac{\lambda D}{x} \text{ where } x = \frac{3.6 \times 10^{-3}}{2L}$$

$$= \frac{5.5 \times 10^{-7} \times 0.29}{3.6 \times 10^{-3}} \times 2L = 9.304 \times 10^{-4} \text{ m}$$

- (d)(i) Describe how plane polarized light can be produced by double refraction

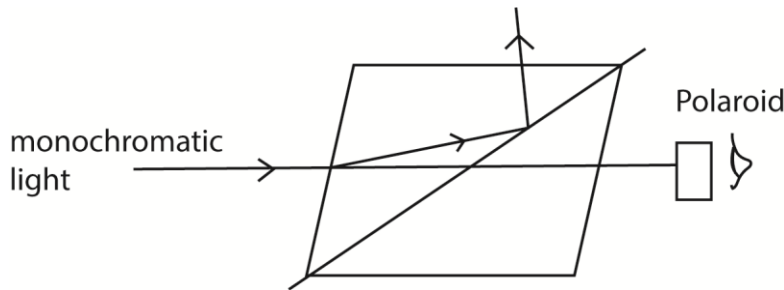

- A narrow beam of monochromatic light is made incident on nicol prism and viewed from the opposite side as shown above
- The angle of incidence is gradually increased or change and at each angle, the Polaroid is rotated about an axis through its plane.
- At one point, the emergent light is plane polarized.

- (ii) Describe practical use of polarized light

- **Polarized light is used in measurement of the concentration of sugar in a solution**

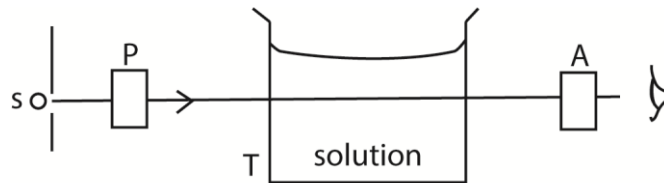

s - source of monochromatic light
P and A are nicol prism
T- glass vessel

The apparatus are arranged as above

First without the solution, the prism A called analyzer is rotated until the emergence light from T is completely extinguished. This orientation is noted.

T is filled with sugar solution, on looking through A, light can now be seen.

A is then again rotated until light is extinguished. This point is noted.

The angle θ between the two positions is noted.

The angle of rotation θ is proportional to the concentration.

- **It is used in stress analysis**

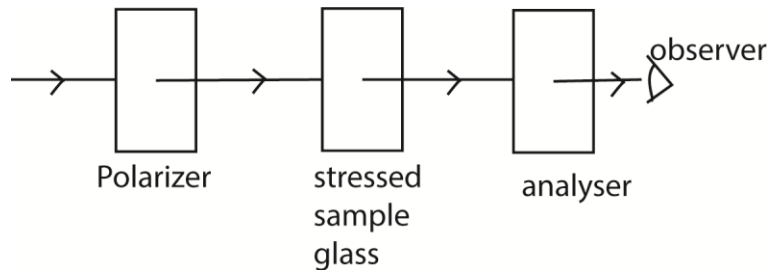

The apparatus is arranged as above

The polarizer and analyzer are Polaroid which are crosses with respect to each other so that light does not pass through.

When a piece of stressed glass is placed between the Polaroid, a pattern of interference fringes can be seen.

The intensity of light depends on the degree of stress and hence the region and degree of stress is determined.

13. (a) What is meant by the following as applied to wave motion?

(xi) Wavelength

This is the distance between two successive particles in phase

(xii) Wave front

This is a section through advancing wave on which all particles are in phase.

(b) (i) Define Resonance

Resonance is a condition obtained when the forcing frequency of an oscillation is equal to the natural frequency of an oscillating (vibrating) object.

(xiii) Describe how velocity of sound can be determined using a resonance tube.

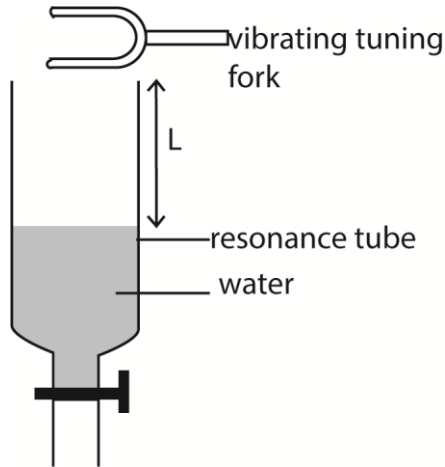

- A glass tube which can be drained from bottom is filled with water.
- A sounding tuning fork of frequency f is brought to the mouth of the tube.
- The water is slowly drained until a loud sound is heard. The tap is closed and length L_1 is measured.
- The tuning fork is again sounded at the mouth of the tube and the water drained further until a loud sound is heard and distance L_2 is noted
- Velocity, v , of sound in air = $2f(L_2-L_1)$

(c) (i) Explain how stationary waves are formed.

When two waves of nearly equal frequency and similar amplitude are sounded together, they superpose.

When they meet in phase, constructive interference takes place and loud sound is heard.

When they meet completely out of phase destructive interference takes place and soft sound is heard.

The periodic rise and fall in intensity of sound heard is called beats.

(ii) A tuning fork of 760Hz is sounded near the open and closed pipe of length 40 cm. If air in the tube resonates with the tuning fork, determine the mode vibration and the end correction. (Velocity of sound in air is 300ms^{-1}).

Assuming negligible end correction

$$\text{Resonance frequency, } f = \frac{nV}{4L}$$

$$n = \frac{4fL}{V} = \frac{4 \times 760 \times 0.4}{330} = 3.68$$

But $n = 1, 2, 3 \dots$

This implies that resonance occurs in the 2nd overtone or 5th harmonic ($n = 5$)

$$\text{If end correction is } c, \text{ then } L + c = \frac{nV}{4f}$$

$$c = \frac{nV}{4f} - L$$

$$= \frac{5 \times 330}{4 \times 760} - 4$$

$$= 0.1428\text{m}$$

(d)(i) Explain reverberation as applied to sound waves

Reverberation is the prolongation of sound after the sound source has been stopped due to large number of reflected waves which can be perceived by the brain as a continuous sound

(ii) Explain how reverberation can be minimized in a large hall.

Reverberation can be reduced by using materials such as fibre board, heavy curtains, plastics that absorb sound as it reaches the walls and ceiling of the room and prevent reflection sound

14. (a) (i) state two conditions necessary for interference patterns to be formed.

- The two sources must be coherent; i.e. they must have the same wavelength and be in phase or have constant phase difference.
- The sources must be close to each other.

(ii) With the aid of a diagram, describe how interference can be produced by division of wave front.

Solution

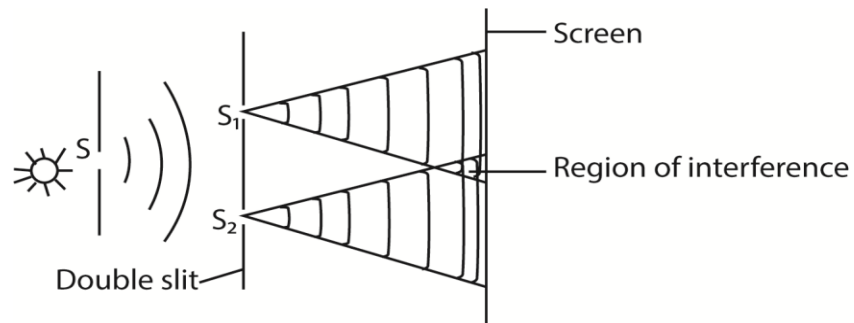

S , S_1 and S_2 are narrow slits parallel to each other. S diffracts light that falls on it and also illuminates both S_1 and S_2 .

Diffraction also takes place at S_1 and S_2 and interference occurs in the region where light from S_1 overlaps that from S_2 .

Since S is narrow, the light which emerges from S_1 and S_2 comes from the same wave front from S and thus coherent.

NB: The coherent sources are obtained by dividing the wave front, originating from a common source, by employing mirrors, biprisms or lenses. This class of interference requires essentially a point source or a narrow slit source.

(b) In Young's double slit experiment, the slits are 0.5mm apart and interference is observed on the screen placed a distance of 100cm from the slits. It is found that the 9th bright fringe is at a distance of 8.84cm from the second dark fringe from the center of the fringe patterns. Find the wavelength of light used.

Solution

The distance of n^{th} bright fringes from the central fringe, $y = \frac{n\lambda D}{a}$

For the 9th bright fringe, $y = \frac{9\lambda D}{a}$ (i)

The distance of the n^{th} dark fringe from the central fringe, $y' = \left(n - \frac{1}{2}\right) \frac{n\lambda}{a}$

The 2nd dark fringe from the central fringe, $y' = \left(2 - \frac{1}{2}\right) \frac{n\lambda D}{a} = \frac{3\lambda D}{2a}$ (ii)

From eqns. (i) and (ii)

$$y_9 - y'_2 = \frac{9\lambda D}{a} - \frac{3\lambda D}{2a} = \frac{15\lambda D}{2a} = 8.84 \times 10^{-2}$$

$$\lambda = \frac{8.84 \times 10^{-3} \times 2 \times 0.5 \times 10^{-3}}{15 \times 1} = 5.59 \times 10^{-6} \text{m}$$

(c) Explain what is observed on the interference pattern fringes in Young’s double experiment when the monochromatic source of light is replaced by a source of white light?

A central white fringe with colored edges is observed.
 White light consists of several component colours. The interference pattern due to the different component colors of white light overlapping.
 At the center of screen, the path difference is zero for all colors. Hence at the center there is a white fringe. Since the violet color has the lowest wavelength, then a violet fringe will be the first fringe on the either side of the central white fringe. The farthest fringe is red
 After a few fringes, the fringe pattern become invisible due to much overlapping.

(d) Describe how interference fringes are formed in wedge shaped film of air.

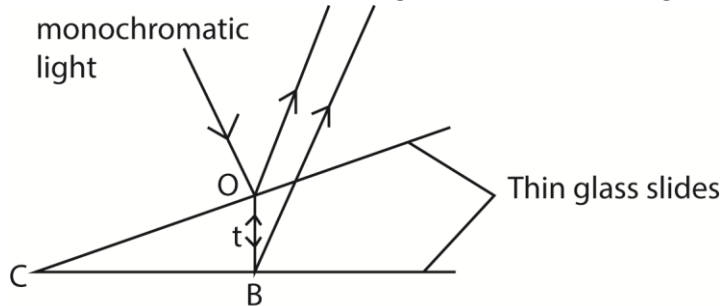

A monochromatic light incident normally at O is partially reflected and partially transmitted at the bottom of the top glass slide.

Part of the transmitted light is reflected at B on the top of the lower glass slide.

The two reflected wave trains are coherent and when they superpose above the upper side of top glass slide, they produce interference pattern in form of alternative dark and bright fringes parallel to the line of intersection of the slide.

The path difference is $2t$ where t is the small thickness of the air film at O.

At C where the path difference is apparently zero, a bright fringe is expected, however, a dark fringe is observed. This is due to phase change of π radians (equivalent to path difference of $\frac{\lambda}{2}$) that occurs when a wave is reflected at a denser medium.

Hence for constructive interference (bright fringes) $(2t + \frac{\lambda}{2}) = n\lambda$, for $n = 1, 2, 3, \dots$

Destructive interference (dark fringes) $2t = n\lambda$, for $n = 1, 2, 3, \dots$

15. (a) (i) Distinguish between free oscillation and damped oscillation.

Free oscillation are oscillations in which the total energy of oscillating system is constant (and the amplitude of oscillation is constant) while a damped oscillation is where the energy of the system decreases with time and the amplitude decreases.

- (ii) What is meant by resonance as applied to sound?

Resonance is said to occur when a system is set to vibrate at its natural frequency due to impulses received from nearby system vibrating at the same frequency.

- (c) Describe an experiment to determine the velocity of sound in air using tuning forks of different frequencies and resonate tube.

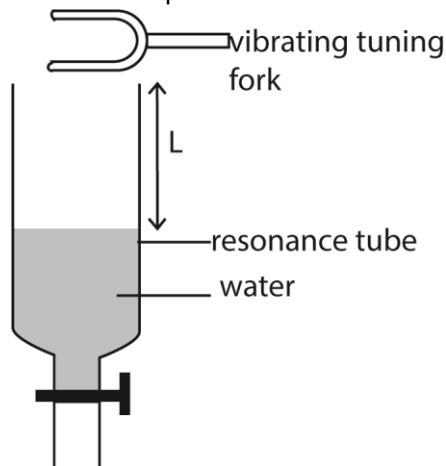

A resonance tube is placed to stand in a tall jar full of water.

Starting with a short length air column, a vibrating tuning fork is held over the mouth of resonance tube. The tube is raised until a point where a loud sound is heard. The length L of the air column and frequency f of tuning fork are recorded.

The experiment is repeated with other five tuning forks of different frequencies

Values of L , f and $\frac{1}{f}$ are tabulated.

A graph of L against $\frac{1}{f}$ is plotted and slope S is determined

The velocity, v , of sound = $4S$.

- (d) A uniform tube of 80cm long is filled with water and a small loudspeaker connected to signal generator is held over the open end of the tube. With the signal generator set at 600Hz, the water level in the tube is lowered until resonance is first obtained when the

length of air column is 13cm. If the third resonance is obtained when the air column is 69.8cm long; calculate the

- (i) Velocity of sound
 $L_1 = 13\text{cm}, L_3 = 69.8$
 Now $L_1 + e = \frac{\lambda}{4}$ (i)
 And $L_3 + e = \frac{5\lambda}{4}$ (ii)
 Eqn. (ii) – eqn. (i)
 $\lambda = 69.8 - 13 = 56.8\text{cm}$ or 0.56m
 Velocity of sound in air, $v = \lambda f = 0.56 \times 600 = 340.8\text{ms}^{-1}$

- (ii) Fundamental frequency for the tube is it were open at both ends.

Solution

If the tube is open at both ends

$$\frac{\lambda_0}{2} = L + 2e$$

$$e = \frac{\lambda_0}{4} - L = \frac{0.568}{4} - 0.13 = 0.012.$$

$$\lambda_0 = 2(L + 2e) = 2(0.8 + 0.024) = 1.648\text{m}$$

$$f_0 = \frac{v}{\lambda_0} = \frac{340.8}{1.648} = 206.8\text{Hz}$$

- (e) (i) What is meant by Doppler Effect?

This is the apparent change in the frequency of a wave, when there is relative motion between the source and observer.

- (xiv) A motor cyclist and police car are approaching each other. The motor cyclist is moving at 10ms^{-1} and the police car at 20ms^{-1} . If the police siren is sounded at 480Hz . Calculate the frequency of the note heard by the cyclist after the police car passes by.

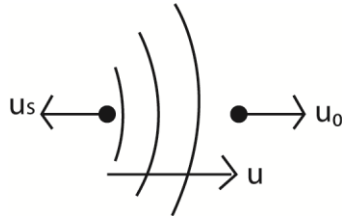

Apparent wavelength reaching the observer, $\lambda' = \frac{v + u_s}{f}$

Apparent velocity of sound received, $v' = v - u_o$

Apparent frequency of sound received, $f' = \frac{v'}{\lambda'} = \frac{v - u_o}{v + u_s} f = \frac{340 - 10}{340 + 20} \times 480 = 440\text{Hz}$

- (xv) Give two applications of the Doppler Effect.

- Determining directional motion of stars
- Estimating speed of stars
- Estimating speed of cars using a speed gun
- Determination of plasma temperature.

16. (a) Explain the formation of fringes by transmission gratings.

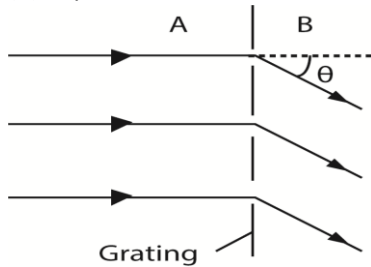

Consider a transmission grating illuminated normally by monochromatic light.

Light is diffracted through the clear space of the grating into a region B where they superpose.

Where the resultant path difference of waves through pairs of consecutive slits is an integral multiple of full wavelength; constructive superposition occurs and a bright band is formed.

Where the resultant path difference is an odd multiple of half a wavelength, destructive superposition occurs and a dark band is formed.

(b) Describe how the wavelength of monochromatic light can be measured using a diffraction grating and a spectrometer.

Solution

Make the following adjustment

- The collimator C is adjusted such that parallel rays emerge from it.
- The telescope is adjusted so that parallel rays entering it are brought to a focus at the cross wire near its eyepiece.
- The table is levelled so that the plane of P is parallel to the axis of rotation of the telescope.

Measurement of wavelength by diffraction grating

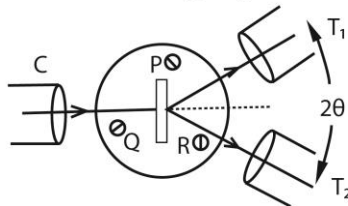

- The grating is placed on the table so that its plane is normal to incident light
- The readings of the first diffraction image are observed on both sides of the normal at T_1 and T_2 .
- The angular difference is 2θ , and the wavelength is calculated from $\lambda = d \sin \theta$, where d is the spacing of the slits, obtained from the number of lines per centimeter of the grating.
- If a second order image is obtained for a diffraction angle θ , then $\lambda = d \sin \theta/2$.

(c) Explain why an oil layer on the water surface appears colored on a rainy day.

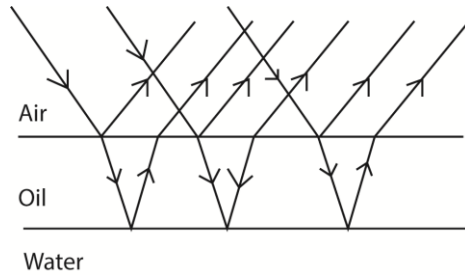

Then white light incident on the oil film, is partly reflected and partly refracted.

Dispersion occurs due to refraction.

The dispersed rays are reflected at oil-water interface.

The light reflected from both surface meet and superpose in air.

Constructive superposition of colored rays give colored fringes. Hence colored oily surface.

(d) Explain

(iii) What is meant by plane polarized light

Plane polarized light is one whose electrical vectors varies in only one plane perpendicular to the direction of travel of the wave.

(iv) One application of polarized light.

- Determination of the concentration of sugars
- In sun glasses to reduce glare.

17. (a) What is meant by the following terms as applied to sound?

(xvi) Resonance

Resonance is said to occur when a system is set to oscillate at own natural frequency as result of impulses received from another system vibrating at the same frequency,

(xvii) Fundamental frequency

This is the lowest frequency an instrument can produce.

(b) Describe an experiment to determine end- correction of resonance tube.

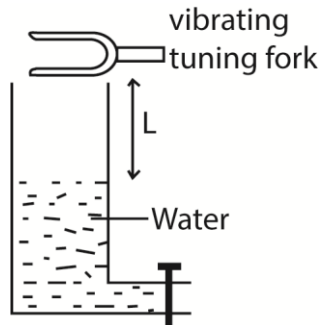

- A sounding tuning fork of known frequency s is held over open end of a tube filled with water
- The water is gradually lowered until a loud sound is heard.
- The length L of air column is measured,
- The procedure is repeated using tuning forks of different frequencies and corresponding length L measured and recorded.
- The results of L , f and $\frac{1}{f}$ are tabulated
- A graph of L against $\frac{1}{f}$ give an intercept c , the end correction of resonance tube.

(c) A wire of length 50cm, density 8.0gcm^{-3} is stretched between two points. If the wire is set to vibrate at fundamental frequency of 15Hz, calculate

(i) The velocity of the wave along the wire

$$L = \frac{\lambda}{2} \text{ or } \lambda = 2L = 2 \times 0.5 = 1\text{m}$$

$$V = \lambda f = 1 \times 15 = 15\text{ms}^{-1}$$

(ii) The tension per unit area of cross section of wire.

$$V = \sqrt{\frac{T}{\mu}}; \mu = \frac{m}{L} = \rho A$$

$$V^2 = \frac{T}{\rho A}$$

$$\frac{T}{A} = V^2 \rho = 15^2 \times 8000 = 1.8 \times 10^6 \text{ Nm}^2$$

(d) Explain using the principle of superposition of wave the formation of

(i) Beats

When two waves of nearly equal frequencies and similar amplitudes are sounded together, they superpose. When they meet in phase constructive interference takes place and loud sound is heard. When they meet completely out of phase, destructive interference takes place and soft sound is heard. A periodic rise and fall in intensity of sound is heard referred to as beats.

(ii) Stationary waves

When two waves of the same frequency, equal wavelength and equal amplitude are propagating in the same medium in opposite direction they meet and superpose; the resultant displacement of particles in medium at any point is the sum of displacements due to each of the waves at that point.

At point where waves meet in phase, the amplitude is maximum. These are antinode. Where the waves meet out of phase a minimum amplitude is formed. The resultant wave is a stationary wave.

18. (a) (i) what is plane polarized light?

Plane polarized light is one in which the variation of electric vector takes place in one plane only.

(ii) Why is it not possible to polarize sound waves?

Sound waves are longitudinal waves whose vibrations are parallel to the direction of propagation of the wave.

(e) (i) Unpolarized light is incident on a sheet of polaroid, A, as shown below

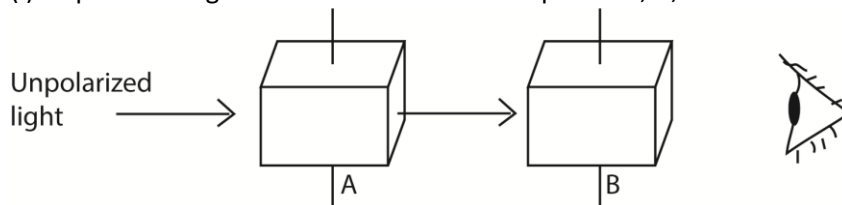

Explain what would be observed if a second polarized sheet B is rotated about an axis perpendicular to the direction of incidence.

Solution

Bright light will be seen or no light will be seen. If the orientation of B is the same as A, bright light is viewed and even when rotated, the bright light remain because the orientation of B does not change its orientation with respect to plane of its polarization

- (xviii) Sunlight is reflected off a glass window of refractive index 1.55. What should be the elevation of the sun be if the reflected light is to be completely polarized?

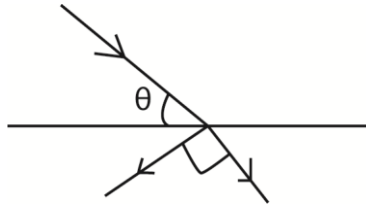

From Brewster's law, $\tan \theta = n = 1.55$
 $\theta = 57.2^\circ$

- (c) Given the diffraction grating and spectrometer, describe how you would use them to measure the wavelength of light from a given source.

Solution

Make the following adjustment

- The collimator C is adjusted such that parallel rays emerge from it.
- The telescope is adjusted so that parallel rays entering it are brought to a focus at the cross wire near its eyepiece.
- The table is levelled so that the plane of P is parallel to the axis of rotation of the telescope.

Measurement of wavelength by diffraction grating

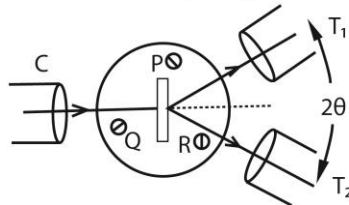

- The grating is placed on the table so that its plane is normal to incident light
- The readings of the first diffraction image are observed on both sides of the normal at T_1 and T_2 .
- The angular difference is 2θ , and the wavelength is calculated from $\lambda = d \sin \theta$, where d is the spacing of the slits, obtained from the number of lines per centimeter of the grating.
- If a second order image is obtained for a diffraction angle θ , then $\lambda = d \sin \theta/2$.

- (d) A parallel beam of monochromatic light of wavelength 650nm is directed normally to diffraction grating which has 600 lines per mm. Determine

(i) the number of diffraction image.

$$d = \frac{1}{600} = 1.67 \times 10^{-3} \text{mm} = 1.67 \times 10^{-6} \text{m}$$

$$\frac{d}{\lambda} = \frac{1.67 \times 10^{-6}}{650 \times 10^{-9}} = 2.57$$

The highest order is 2 and total number of images is 5

(ii) the angle of diffraction of the highest order diffraction image.

$$\sin \theta = \frac{m\lambda}{d} = \frac{2 \times 650 \times 10^{-9}}{1.67 \times 10^{-6}}$$

$$\theta = 51.1^\circ$$

19. (a) (i) Define the terms wave front and a ray in reference to a progressive wave (02mark)

Wave front is a section through an advancing wave along which all particles are in phase along a ray in the direction of advancing wave.

(ii) Draw a sketch diagram showing reflection of a circular wave by a plane reflector.

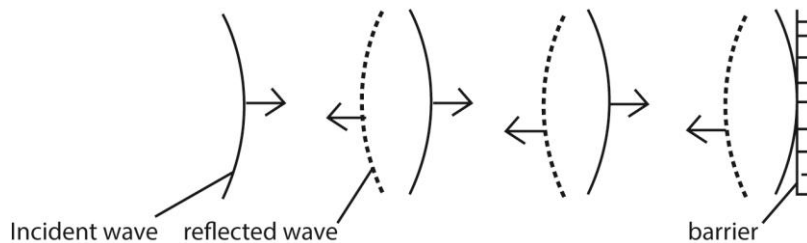

(b) The figure below shows a wave travelling in positive x- direction away from origin with a velocity of 9ms^{-1} .

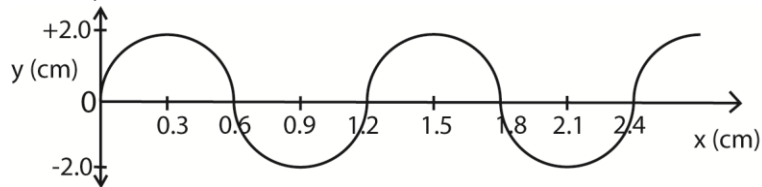

(i) What is the period of the wave? (03marks)

$$\text{Wavelength} = 1.2\text{cm} = 0.12\text{m}$$

$$\text{Velocity} = 9\text{ms}^{-1}$$

$$\text{Period, } T = \frac{\lambda}{v} = \frac{1.2 \times 10^{-2}}{9} = 1.3 \times 10^{-3}\text{ms}^{-1}$$

(ii) Show that the displacement equation for the wave is $y = 2\sin\frac{5}{3}\pi(900t - x)$ (03marks)

The wave is moving from left to right

$$\text{c.f. } y = a\sin 2\pi\left(ft - \frac{x}{\lambda}\right)$$

here $a = 2\text{cm}$, $f = 750\text{Hz}$, and $\lambda = 1.2$

$$\therefore y = 2\sin 2\pi\left(750t - \frac{x}{1.2}\right)$$

Or

$$\text{c.f. } y = a\sin\frac{2\pi}{\lambda}(vt - x)$$

here $a = 2\text{cm}$, $\lambda = 1.2\text{cm}$, and $v = 900\text{cms}^{-1}$

$$y = 2\sin\frac{2\pi}{1.2}(900t - x)$$

$$= 2\sin\frac{20\pi}{12}(900t - x)$$

$$= 2\sin\frac{5\pi}{3}(900t - x)$$

(c) What is meant by Doppler Effect? (01mark)

This is the apparent change in frequency of a wave due to relative motion between the source and observer.

(d) One species of bats locates obstacles by emitting high frequency sound waves and detecting the reflected waves. A bat flying at a steady speed of 5ms^{-1} emits sound of frequency 78.0 kHz and is reflected back to it.

(i) Derive the equation for the frequency of the sound waves reaching the bat after reflection (05marks)

Suppose the velocity of sound wave is c and that of the bat is v_0 and the frequency is f .

The velocity v' of reflected sound relative to the bat is given by $v' = v_0 + c$.

The apparent wave length $\lambda' = \frac{c - v_0}{f}$

But the apparent frequency, $f' = \frac{v'}{\lambda'} = \frac{c + v_0}{\frac{c - v_0}{f}}$

$$\text{Hence } f' = \frac{c + v_0}{c - v_0} f$$

(ii) Calculate the frequency of sound received by the bat given the speed of sound in air is 340ms^{-1} . (02 marks)

$$\text{From, } f' = \frac{c + v_0}{c - v_0} f$$

$$f' = \frac{340 + 5}{340 - 5} \times 78 \times 10^3 = 90.3\text{ kHz}$$

(e) (i) What is meant by intensity of a sound note? (01mark)

This is the rate of flow of energy through an area of 1m^2 perpendicular to the direction of flow of sound wave.

(xix) Distinguish between loudness and pitch of a sound note. (01mark)

Loudness of sound is dependent on intensity whereas pitch is dependent frequency, i.e. the higher the frequency the higher the pitch.

20. (a) What is meant by the following terms

(xx) Unpolarized light, (01mark)

Unpolarized light is one whose vibrations in electric and magnetic vectors take place in more than one plane.

(xxi) Plane polarized light (01mark)

It is the one whose electric vector varies in only one plane.

(b) (i) Describe briefly how plane polarized light is produced by double refraction (03marks)

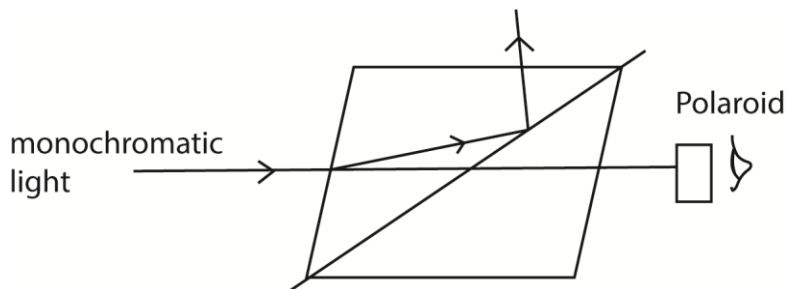

- A narrow beam of ordinary light is made incident on nicol prism and viewed through analyzer as shown above
- The angle of incidence is gradually increased or change and at each angle, the Polaroid is rotated about an axis through its plane.
- At certain angle of incidence, light is completely extinguished
- At this point, the emergent light is plane polarized.

(ii) Explain briefly one application of polarized light. (02marks)

- When polarized light is passed through a stressed material, bright and dark fringes are seen on screen which vary according to the concentration of stress. Thus stress analysis.
- In determination of the concentration of sugar in solution, polarized light is passed through the solution and viewed through an analyzer. The analyzer is turned through angle until light is extinguished. This angle is proportional to the concentration

(c) Explain

(i) How two coherent sources are obtained using a biprism (03marks)

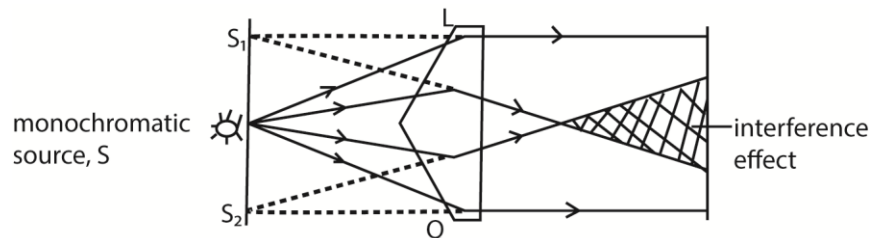

- A prism of a very large angle is placed with its refractive edge facing a monochromatic source of light, S.
- Light incident on face L is refracted to appear to come from a point S₁ and that incident on Q appears to come from S₂ due to refraction.
- The two sources are coherent since they originate from the same source S leading to interference where they superpose.

(ii) Why interference effects are not observed in thick films (03marks)

The bright fringes are formed when the path difference, $d = \left(n - \frac{1}{2}\right) \lambda$, where $n = 1, 2, 3 \dots$

But for thick film illuminated normally with white light, each color attains this path difference and form bright bands. So when these different colors overlap leading cause uniform illumination and the interference pattern disappear.

- (d) In Young's double slit experiment, the slits are separated by 0.28mm and the screen is 4m away. The distance between the fourth bright fringe and the central fringe is 1.2cm. Determine the wavelength of light used in the experiment. (04marks)

Solution

The distance between the fourth and bright fringes and the central fringe is equivalent to the separations.

$$4y = 1.2 \times 10^{-2} \text{m where } y \text{ is the fringe separation}$$

$$y = 3 \times 10^{-3} \text{m}$$

from $\lambda = \frac{ay}{D}$ where a is the slit separation and D is the fringe-screen difference

$$\lambda = \frac{0.28 \times 10^{-3} \times 3.0 \times 10^{-3}}{4} = 2.1 \times 10^{-7} \text{m}$$

- (e) Explain the effect of increasing the number of narrow slits in diffraction grating on the intensity of diffraction fringes. (03marks)

Increasing the number of slits, the intensity of the principal maxima increases while that subsidiary maxima decreases. The interference at the principal maxima are always constructive hence intensity increases. Interference at the subsidiary maxima is always destructive, hence the intensity decreases.

21. (a) (i) Define amplitude of a wave. (01mark)

It is the maximum displacement of a particle in a transmitting medium from its equilibrium position

- (ii) State two characteristics of a stationary wave (02 mark)

- Amplitude of a wave varies from place to place along the profile.
- Wave energy is not transmitted along the profile.
- At certain points called nodes, the particles are permanently at rest
- Has nodes and antinodes.

- (iii) A progressive wave $y = a \sin(ax - kt)$ is reflected at a barrier to interfere with the incoming wave. Show that the resultant is a stationary wave (04marks)

Incident wave $y_1 = a \sin(\omega t - kx)$

Reflected wave $y_2 = a \sin(\omega t + kx)$

Resultant wave $= y_1 + y_2$

$$= a \sin(\omega t - kx) + a \sin(\omega t + kx)$$

$$= 2a \sin \frac{2\omega t}{2} \cos \left(\frac{-2kx}{2} \right)$$

$$= 2a \sin \omega t \cos kx$$

$$= (2a \cos kx) \sin \omega t$$

$$= A \sin \omega t$$

Where A is the amplitude of a wave

Now $A = 2a \cos kx$ varies with distance x.

Therefore the wave is a stationary one.

- (f) (i) What is meant by beats? (02marks)

A beat is the periodic rise and drop in intensity of sound heard when two notes of nearly equal frequency are sounded together.

(ii) Describe how you can determine the frequency of a musical note using beats. (05marks)

The musical note is sounded together with a tuning fork of known frequency, f_1 . The number of beats, n , in time, t , are counted.

$$\text{Beat frequency, } f_b = \frac{n}{t}$$

One prong of the tuning fork is loaded with plasticine and then the experiment is repeated.

$$\text{New beat frequency, } f'_b = \frac{n}{t} \text{ is determined.}$$

If $f_b > f'_b$, then the frequency of the test note, $f_n = f_T - f_b$.

If $f_b < f'_b$, then the frequency of test note, $f_n = f_b + f_T$.

(c) Two open pipes of length 92cm and 93cm are found to give beat frequency of 3.0Hz when each is sounding in its fundamental note. If the end errors are 1.5cm and 1.8cm respectively, calculate the

(i) velocity of sound in air (04marks)

$$\text{From beat frequency, } f_0 = \frac{v}{2(L_1 + 2c_1)}$$

$$\begin{aligned} f_b &= f_{92} - f_{93} \\ &= \frac{v}{2(L_1 + 2c_1)} - \frac{v}{2(L_2 + 2c_2)} \\ 3 &= \frac{v}{2} \left(\frac{1}{(0.92 + 2 \times 0.015)} - \frac{1}{(0.93 + 2 \times 0.018)} \right) \\ v &= 344.14 \text{ms}^{-1} \end{aligned}$$

(ii) frequency of each note (02mark)

$$\begin{aligned} f_0 &= \frac{v}{2(L_1 + 2c_1)} \\ f_{92} &= \frac{344.14}{2(0.92 + 2 \times 0.015)} = \frac{344.14}{2 \times 0.95} = 181.13 \text{Hz} \\ f_{93} &= \frac{344.14}{2(0.93 + 2 \times 0.018)} = \frac{344.14}{2 \times 0.966} = 178.13 \text{Hz} \end{aligned}$$

22. (a) (i) Define the term diffraction. (01mark)

Diffraction is the spreading of a wave beyond its geometrical shadow (boundaries) leading to interference.

(ii) What is meant by plane polarized light? (01mark)

Plane polarized light is one in which the variation of its electric vector takes place in one plane only.

(g) (i) Describe how polarized light is produced by double refraction. (05 marks)

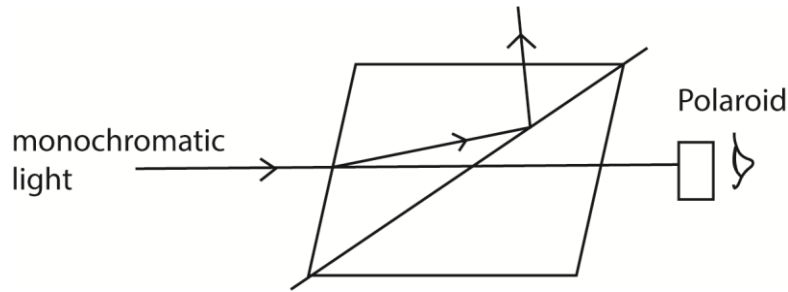

- A narrow beam of ordinary light is made incident on nicol prism and viewed through analyzer as shown above
- The angle of incidence is gradually increased or change and at each angle, the polaroid is rotated about an axis through its plane.
- At certain angle of incidence, light is completely extinguished
- At this point, the emergent light is plane polarized.

(xxii) State two uses of polarized light (02mark)

Used in sunglasses to reduce glare

Used in photo-elasticity to identify regions of stress in a material

Used to determine the concentration of sugars

(xxiii) A parallel beam of unpolarized light incident on transparent medium of refractive index 1.62, is reflected as polarized light. Calculate the angle of incident in air and angle of refraction in the medium (03marks)

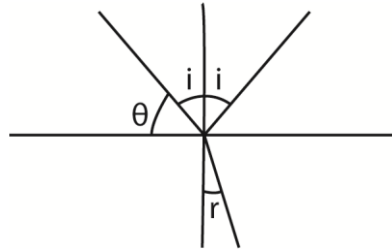

By Brewster's law, if reflected ray is polarized, $\tan \theta = n = 1.62$

$$\theta = 58.3^\circ$$

Angle of incidence, $i = 90 - 58.3^\circ = 31.7^\circ$.

$$\text{From } n = \frac{\sin i}{\sin r}$$

$$1.62 = \frac{\sin 31.7}{\sin r}; r = 19^\circ$$

(c) (i) what is diffraction grating? (01mark)

A diffraction grating is a transparent plate with many small parallel lines drawn on it using a diamond pencil

(ii) Sodium light of wavelength $5.890 \times 10^{-7} \text{m}$ and $5.896 \times 10^{-7} \text{m}$ fall normally on a diffraction grating. If the first order beam, the two sodium lines are separated by 2 minutes, find the spacing of grating (03marks)

For first order diffraction, $d \sin \theta = \lambda$

$$\sin \theta_1 = \frac{\lambda_1}{d} \dots\dots\dots (i)$$

$$\sin \theta_2 = \frac{\lambda_2}{d} \dots\dots\dots (ii)$$

$$\text{but } \sin \theta_2 = \left(\theta_1 + \frac{2}{60} \times \frac{\pi}{180} \right)$$

Eqn. (ii) – Eqn. (i)

$$\begin{aligned} \sin \left(\theta_1 + \frac{\pi}{60 \times 180} \right) - \sin \theta_1 &= \frac{\lambda_2 - \lambda_1}{d} \\ &= 2 \cos \left(\theta_1 + \frac{\pi}{60 \times 180} \right) \sin \left(\frac{\pi}{60 \times 180} \right) = \frac{\lambda_2 - \lambda_1}{d} \\ &= \left(\frac{5.896 - 5.890}{d} \right) \times 10^{-7} \end{aligned}$$

(d) State three differences between the spectra produced by a prism and that by diffraction grating. (03marks).

Prism	Diffraction grating
- Produce single spectrum at a time	- Many spectra at a time
- Shorter wavelengths are deviated most	- Longer wavelength are deviated most.
- Produce less pure spectrum	- Produce more pure spectrum

23. (a)(i) A progressive wave represented by $y = a \sin 2\pi \left(\frac{t}{T} - \frac{x}{\lambda} \right)$ is reflected along the same path. Show how the overlap of the two waves may give rise to a stationary wave. (03marks)

$$y_1 = a \sin 2\pi \left(\frac{t}{T} - \frac{x}{\lambda} \right)$$

A wave travelling in opposite direction is given by

$$y_2 = a \sin 2\pi \left(\frac{t}{T} + \frac{x}{\lambda} \right)$$

When the two waves superpose, the resultant displacement is $y = y_1 + y_2$.

$$\begin{aligned} y &= a \sin 2\pi \left(\frac{t}{T} - \frac{x}{\lambda} \right) + a \sin 2\pi \left(\frac{t}{T} + \frac{x}{\lambda} \right) \\ &= 2a \cos \frac{2\pi x}{\lambda} \sin \frac{2\pi t}{T} \end{aligned}$$

This is stationary wave with amplitude $2a \cos \frac{2\pi x}{\lambda}$

- (ii) In an experiment to determine the speed of sound in air in a tube, chalk dust settled in heaps as shown below

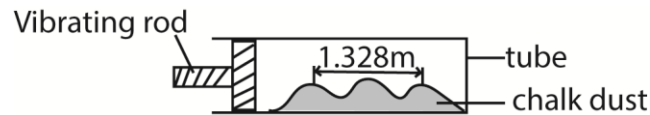

If the frequency of the vibrating rod is 252Hz and the distance between three consecutive heaps is 1.328m, calculate the speed of sound in air.

From the diagram.

$$\frac{\lambda}{2} = \frac{1.328}{2}; \lambda = 1.328\text{m}$$

$$v = f\lambda$$

$$= 252 \times 1.328 = 334.7\text{ms}^{-1}.$$

- (b) The speed of sound in air is given by $v = \sqrt{\frac{\gamma P}{\rho}}$ where P is the pressure, ρ the density and γ the ratio of the principal heat capacities of air. Use this expression to explain the effect of temperature on the speed of sound in air (03marks)

Solution

When the temperature of air is increased, the pressure increases. If the air is not restricted in volume, it expands leading to a reduction in density. From the above expression, a reduction in density leads to increase in velocity. Hence increase in temperature leads to increase in velocity of sound.

Or

$$v = \sqrt{\frac{\gamma P}{\rho}}$$

From $PV = nRT$, where R is constant.

If the air is restricted in volume, ρ is constant so that $P \propto T$. From the above expression, speed of sound in air increases with increase with temperature.

- (c)(i) A train moving with uniform velocity, v_1 sounds a horn as it passes a stationary observer. Derive expression for the apparent frequency of sound detected by the observer. (03marks)

f waves occupy a distance $v + v_1$ in one second.

Apparent wavelength $\lambda_a = \frac{v + v_1}{f}$

\therefore Apparent frequency, $f_a = \left(\frac{v}{v + v_1}\right) f$; where v is the speed of sound in air, and f is the true frequency of the note sounded.

(ii) If the frequency of the sound detected by the observer after the train passes is 1.2 times lower than the frequency detected in (c)(i), find the speed of the train.

[Speed of sound in air = 330ms^{-1}]

NOT POSSIBLE

(d) Describe a simple experiment to show interference of longitudinal waves. (04marks)

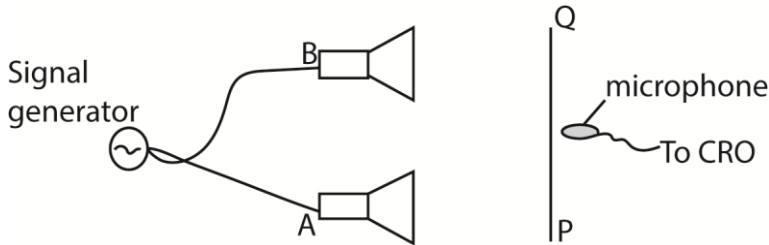

Two loud speaker A and B were connected to a signal generator. A microphone connected to the y-plates of s C.R.O with the time base switched off.

As the microphone is moved along the line PQ which is parallel to the line joining the loud speaker, the vertical trace on the screen of CRO is seen to increase to maximum and reduce to minimum at equal distances. The alternative maximum and minimum intensity are interference pattern.

Or

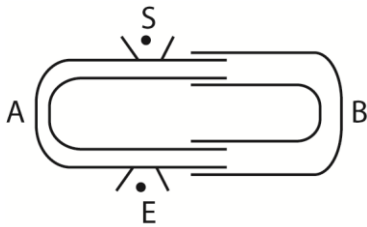

Tube A is fixed while B is free to move. A note is sounded at S and detected at E. Tube B s then pulled out slowly. It is noted that the sound detected E increases to a maximum and reduces to minimum intensity at equal intervals of the length of the tube. The alternate maximum and minimum intensity formed are interference pattern.

24. (a) State three differences between mechanical and electromagnetic waves (03marks)

Mechanical wave	Electromagnetic waves
- Need material medium for propagation	- Can propagate in vacuum
- Propagate at relatively low speed	- Propagate as very high speed
- Have longer wavelength	- Shorter wavelength
- Are due to vibration or oscillation of particles in transmitting medium.	- Are due to vibration in electric and magnetic field

(b)(i) State the principal of superposition of waves (01mark)

The resultant displacement at any point is the sum of displacements due to the separate waves.

(ii) Explain how interference pattern is formed (03marks)

When two waves from coherent source sources cross they superpose. Where the path difference is odd multiple of a half a wavelength, cancellation occurs resulting in minimum intensity.

Where the path difference is equal to integral multiple of a full wavelength, reinforcement occurs resulting in maximum intensity. This leads to formation of alternate permanent regions of maximum and minimum intensity called interference.

(c)

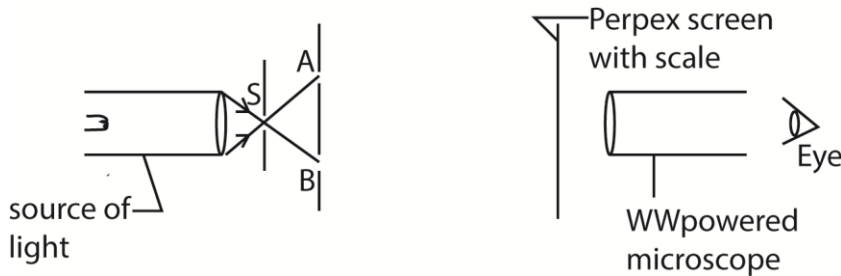

A source of light, a single slit, S, and a double slit (A and B) are arranged as shown in figure 2.

(i) Describe what is observed on the screen through the microscope when white source of light is used. (02marks)

Sets of numerous colored fringes are seen on screen. The central fringe is white with colored fringes on either side. For each set, blue fringe is nearest to the central one while red is farthest.

(ii) How would you use the set up above to compare the wavelength of red and blue light? (04marks)

A source of white light is used. A red filter is placed in front of the slits. The number of bright fringes in fixed length on the screen is counted and fringe separation, y_r is determined. The red filter is replaced by a blue filter and experiment repeated and fringe separation y_b is determined. It is found $y_r > y_b$

Since fringe separation y is proportional to wave length, from $y = \frac{\lambda D}{d}$

It implies that the wavelength of red light is greater than wavelength of blue light.

(iii) Explain what is observed when slit, S, is gradually widened. (03marks)

Fringes gradually disappear. A large slit S is equivalent to many narrow slits that the fringes overlap to form uniform illumination.

(d) A diffraction grating of 500 lines per mm is illuminated normally by light of wavelength 5.26×10^{-7} m. Find the total number of images seen. (04marks)

$$\sin \theta_{\max} = \frac{n_{\max}}{d} = 1$$

$$n_{\max} = \frac{d}{\lambda} = \frac{\frac{1}{500} \times 10^{-3}}{5.26 \times 10^{-7}} = 3.8$$

∴ total number of images seen is 7.

25. (a) (i) What is a wave? (01mark)

A wave is a periodic disturbance that travels with a definite velocity through the medium.

(ii) Explain why an open tube is preferable as a musical instrument. (03marks)

A closed pipe gives only odd numbered harmonics while an open pipe produced both odd and even numbered harmonics. Hence open pipe gives many different overtones and thus better quality musical notes than closed pipes.

(b) (i) State two factors that affect the speed of sound in air (01mark)

- Temperature of the air
- Humidity of the air
- Wind velocity

(xxiv) Explain the term reverberation. (02mark)

Reverberation occurs when sound produced at one instant by a source is closely followed by its echo. This is due to the reflecting surface being too close to the source. Therefore the observer fails to distinguish between the original sound and its echo; the observer gets the impression that the original sound is prolonged.

(xxv) What is the implication of reverberation in a hall? (02marks)

The soft clothing of the audience absorb the sound instead of reflecting it. Consequently, the music and speech appear to be weaker. Reverberation of a small degree is necessary because it enhance audibility. However, if it is too long, it makes music and speech sound confused and indistinct.

(c) Describe an experiment to determine the velocity of sound in air using resonance method. (06mark)

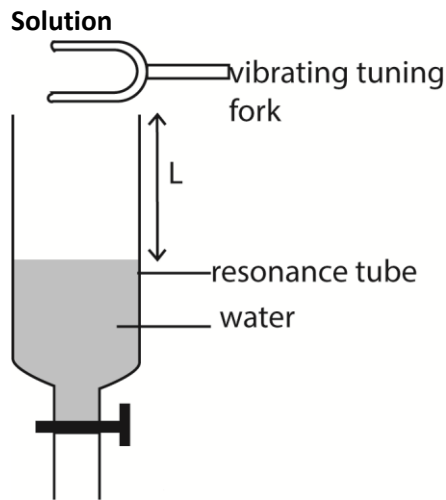

A resonance tube is placed to stand in a tall jar full of water. Starting with a short length air column, a vibrating tuning fork is held over the mouth of resonance tube. The tube is raised until a point where a loud sound is heard. The length L of the air column and frequency f of tuning fork are recorded.

The experiment is repeated with other five tuning forks of different frequencies

Values of L , f and $\frac{1}{f}$ are tabulated.

A graph of L against $\frac{1}{f}$ is plotted and slope S is determined

The velocity, v , of sound = $4S$.

Or

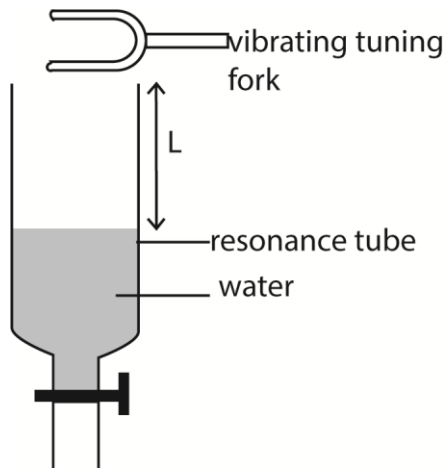

- A glass tube which can be drained from bottom is filled with water.
- A sounding tuning fork of frequency f is brought to the mouth of the tube.
- The water is slowly drained until a loud sound is heard. The tap is closed and length L_1 is measured.
- The tuning fork is again sounded at the mouth of the tube and the water drained further until a loud sound is heard and distance L_2 is noted
- Velocity, v , of sound in air = $2f(L_2 - L_1)$

(d) (i) What is harmonic in sound? (01mark)

Harmonic is one of the frequencies that can be produced by a given instrument (both stringed and piped)

- (ii) A string of length 0.5m and mass 50g is stretched between two fixed points. If the tension in the string is 100N, find the frequency of second harmonic. (04marks)

From $f = \frac{v}{\lambda}$ (i)

But $v = \sqrt{\frac{T}{\mu}}$; where μ is the mass per unit length.

$$\mu = \frac{5 \times 10^{-3}}{0.5} = 0.01 \text{kgm}^{-1}$$

$$v = \sqrt{\frac{100}{0.01}} = 100 \text{ms}^{-1}$$

For second harmonic, first overtone, $\lambda = L = 0.5\text{m}$

Substituting in eqn. (i) $f = \frac{100}{0.5} = 200\text{Hz}$

26. (a) Distinguish between constructive and destructive interference. (03marks)

Constructive interference occurs when two waves superpose in phase whereas destructive interference occurs when two waves are superposed out of phase.

- (b) (i) Explain how interference fringes formed in air-wedged film between two glass slides when monochromatic light is used. (06marks)

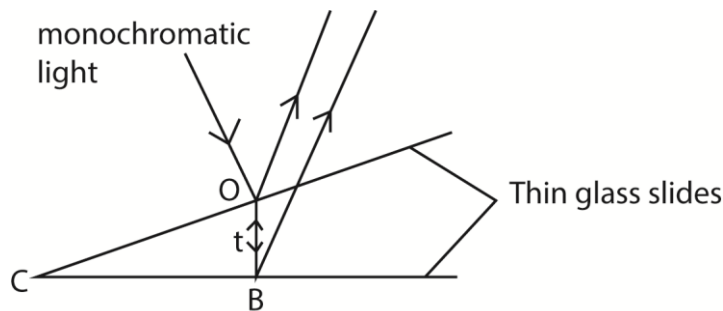

When light from monochromatic source is reflected down towards the wedge and is partially reflected upwards from the bottom of the top glass slide and partially transmitted through the air film at O to point B where it is reflected upwards.

The two wave trains are coherent and when they superpose above the upper side, they produce interference pattern in form of alternative dark and bright fringes parallel to the line of intersection of the slide.

The path difference is $2t$ where t is the small thickness of the film at O.

At C where the path difference is apparently zero, a bright fringe is expected, however, a dark fringe is observed. This is due to phase change of π radians (equivalent to path difference of $\frac{\lambda}{2}$) that occurs when a wave is reflected at a denser medium. λ

Hence for constructive interference (bright fringes) $(2t + \frac{\lambda}{2}) = n\lambda$, for $n = 1, 2, 3...$

Destructive interference (dark fringes) $2t = n\lambda$, for $n = 1, 2, 3 ...$

(xxvi) Describe the appearance of fringes when white light is used. (02marks)

Colored fringes are observed.

- (c) Two glass slides in contact at one end are separated by a sheet of paper 15cm from the line of contact to form an air-wedge. When the air wedge is illuminated normally by light of wavelength $6.0 \times 10^{-7} \text{m}$, interference fringes of separation 1.8mm are found in reflection. Find the thickness of the paper. (04marks).

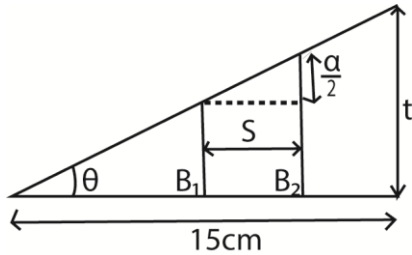

$$S = 1.8 \times 10^{-3} \text{m}$$

$$\tan \theta = \frac{\lambda}{2S} = \frac{t}{L}$$

$$t = \frac{\lambda L}{2S} = \frac{6.0 \times 10^{-7} \times 15 \times 10^{-2}}{2 \times 1.8 \times 10^{-3}} = 2.5 \times 10^{-5} \text{m}$$

- (d) (i) Describe, with aid of a labelled diagram, one method of producing plane polarized light. (04marks)

Solution

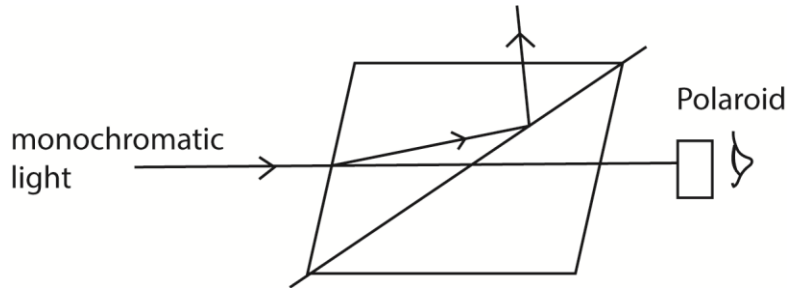

- A narrow beam of ordinary light is made incident on nicol prism and viewed through analyzer as shown above
- The angle of incidence is gradually increased or change and at each angle, the polaroid is rotated about an axis through its plane.
- At certain angle of incidence, light is completely extinguished
- At this point, the emergent light is plane polarized.

Or

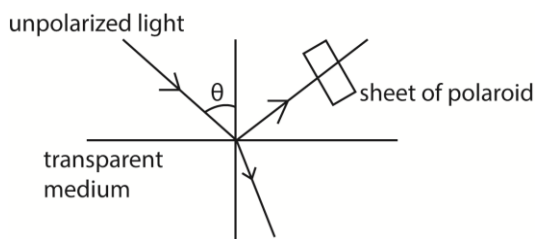

- A narrow beam of unpolarized light is made incident on transparent medium.
- The reflected light is observed through a Polaroid.
- The angle of incidence is varied
- At each angle of incidence, the polaroid is rotated about the axis along the light incident on it
- At one angle of incidence, the light gets cut off the observer as the Polaroid is rotated.
- The reflected ray is now completely polarized.

(xxvii) State two uses of polarized light. (01mark)

- Determination of sugar concentration
- Stress analysis in some materials like glass

27. (a) State three differences between sound and light waves. (03marks)

Mechanical wave	Electromagnetic waves
<ul style="list-style-type: none"> - Need material medium for propagation - Propagate at relatively low speed - Have longer wavelength - Are due to vibration or oscillation of particles in transmitting medium. 	<ul style="list-style-type: none"> - Can propagate in vacuum - Propagate as very high speed - Shorter wavelength - Are due to vibration in electric and magnetic field

(b) Distinguish between free and damped oscillation? (02marks)

Free oscillation	Damped oscillation
<ul style="list-style-type: none"> - Amplitude is constant - Wave energy is constant 	<ul style="list-style-type: none"> - Amplitude decreases with time - Wave energy decreases with time

(c) (i) What is meant by resonance? (02marks)

Resonance occurs when the forcing frequency in an oscillation is equal to natural frequency of the oscillating (vibrating) body. The body then oscillates (vibrates) with maximum or constant amplitude.

(xxviii) Describe with aid of diagram, an experiment to investigate the variation of frequency of stretched string with length. (06marks)

A sonometer below is used

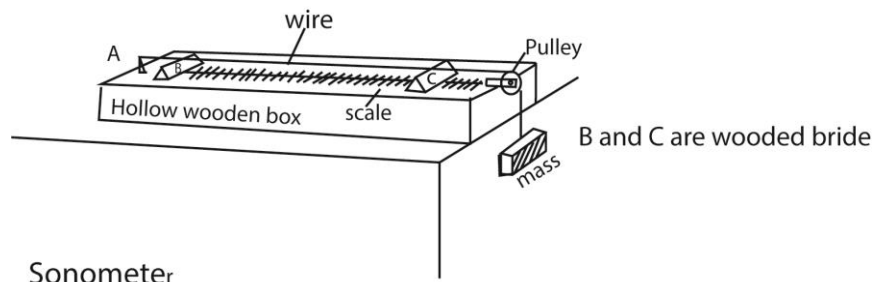

Sonometer

- The wooden bridges B and C vary the effective length of the wire, L.
- Constant tension in the wire is maintained by the fixed mass
- A paper rider is placed on the wire in the middle of BC and a sounding fork placed near it.
- The position of the bridge C is varied until sound is heard.
- The distance between the bridges L and the frequency, f , of the tuning fork is noted.
- The procedure is repeated for various tuning forks and values of L, f and $\frac{1}{L}$ are tabulated
- A plot of f against $\frac{1}{L}$ gives a straight line showing that the frequency of vibration of the wire is inversely proportional to length. I.e. frequency increases as length decreases.

(d) (i) Calculate the frequency of beats heard by stationary observer when a source of sound of frequency 80Hz is receding with a speed of 5.0ms^{-1} towards a vertical wall. (speed of sound in air = 340ms^{-1}) (05marks)

Solution

$$\text{Apparent frequency of direct sound} = \frac{340}{340+5} \times 80 = 78.8\text{Hz}$$

$$\text{Apparent frequency of reflected sound} = \frac{340}{340-5} \times 80 = 81.2\text{Hz}$$

$$\text{Frequency of the beats heard} = (81.2 - 78.8) = 2.4\text{Hz}$$

(ii) State two uses of beats. (02marks)

- Tuning musical instrument to a desired note
- Determining the unknown frequency of a note

28. (a) State Huygens' Principle. (01 mark)

Every point on a wave front may be regarded as a source of secondary spherical wavelets which spread out with the wave velocity. The new wave front is the new envelope of these secondary wavelets.

(b) Monochromatic light propagating in air is incident obliquely onto a plane boundary with a dielectric of refractive index, n .

(i) Use Huygens' principle to show that speed, V , of light in the dielectric is given by $V = \frac{c}{n}$ where c is the speed of light. (06marks)

Consider a beam of parallel rays between LO and MD incident on the plane surface of the medium from air in the direction shown, and suppose that a plane wave front has reached the position OA at a certain instant,

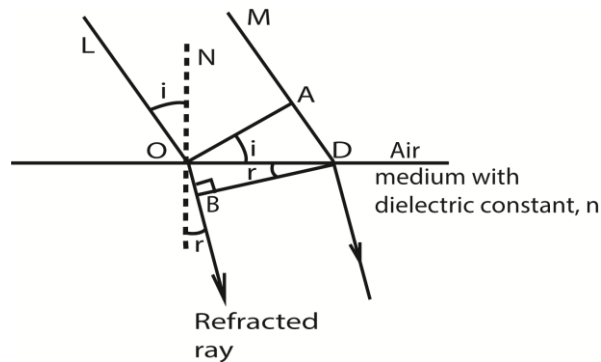

In figure above, each point between O, D becomes a new centre of disturbance as the wave front advances to the surface of the medium, and the wave front changes in direction when the disturbance enters the medium.

Suppose that t is the time taken by the light to travel from A to D. The disturbance from O travels a distance OB, or Vt , in the medium in a time t , where v is the velocity of light in medium.

At the end of the time t , the wave fronts in the medium from the other secondary centres between O, D reach the surfaces of spheres to each of which DB is a tangent.

Thus DB is the new wave front in the water, and the ray OB which is normal to the wave front is consequently the refracted ray.

Since c is the velocity of light in air, $AD = ct$.

Now

$$\frac{\sin i}{\sin r} = \frac{\sin LON}{\sin BOM} = \frac{\sin AOB}{\sin ODB}$$

$$n = \frac{\sin i}{\sin r} = \frac{AD}{OD} \div \frac{OB}{OD} = \frac{AD}{OD} \times \frac{OD}{OB} = \frac{AD}{OB} = \frac{ct}{vt} = \frac{c}{v}$$

$$v = \frac{c}{n}$$

- (ii) If the wavelength of the light is 600nm in air, what will it be in a dielectric of refractive index 1.50? (04marks)

Let f_0 and f be frequencies of light in vacuum and in the medium, then

$$f_0 = f$$

$$\frac{c}{f_0} = \frac{v}{f}$$

$$\text{But } \frac{\lambda_0}{\lambda} = \frac{c}{v} = n$$

$$\lambda = \frac{\lambda_0}{n} = \frac{600}{1.5} = 400\text{nm}$$

(c) (i) What is meant by interference of waves? (01mark)

It is superposition of waves resulting into alternate regions of maximum and minimum intensity.

(xxix) State the conditions necessary for interference fringes to be observed, (02mark)

- The wave trains must have nearly the same or equal amplitudes.
- There must be a constant phase relationship between the two wave trains.
- The source must be very close to each other.
- The screen must be very far as possible from the sources.

(xxx) Explain the term path difference with reference to interference of two wave-motions.

Path difference is difference in distances travelled by two wave trains from secondary sources to the point of overlap. Where they meet, the two waves superpose leading to reinforcement or cancellation. Where the path difference is an integral multiple of a wavelength, constructive interference takes place. Where the path difference is an odd multiple of half a wave length, destructive interference takes place.

(d) Two glass slide in contact at one end are separated by a wire of diameter 0.04mm at the other end to form a wedge. Fringes are observed when light of wavelength 5.0×10^{-7} m is incident normal to the slides. Find the number of fringes which can be observed. (03marks)

Solution

$$2t = \rho\lambda$$

$$\rho = \frac{2t}{\lambda} = \frac{2 \times 0.04 \times 10^{-3}}{5 \times 10^{-7}} = 160$$

29. (a) (i) What is meant by amplitude and wavelength as applied to wave? (02marks)

Amplitude is the maximum displacement of a particle in the transmitting medium from the mean position.

Wavelength is the distance between two successive crests or troughs in a wave or the distance between two adjacent particles in the medium which are in phase for a progressive wave.

(ii) State differences between progressive and stationary waves

Progressive wave	Stationary wave
<ul style="list-style-type: none"> - There is energy flow along the wave - Vibrations are the same amplitude and same frequency - Phase of vibration changes for different points along the wave - Particles in phase are $n\lambda$ apart, $n = 1, 2, 3$ 	<ul style="list-style-type: none"> - No energy flow - Amplitudes different and depend on position along the wave - Some points are permanently fixed - Particles at distance $\frac{n\lambda}{2}$ apart are in phase

(b) The displacement, y , of a wave travelling in the x - direction is given at time, t , by

$$y = a \sin 2\pi \left(\frac{t}{0.5} - \frac{x}{2.0} \right) \text{ meters}$$

Find the speed of the wave (04marks)

Compare with $y = a \sin \pi \left(ft - \frac{x}{\lambda} \right)$

$$f = \frac{1}{0.5} = 2 \text{ Hz and } \frac{1}{\lambda} = \frac{2}{2}; \lambda = 2 \text{ m}$$

From $v = f\lambda$

$$v = 2 \times 2 = 4 \text{ ms}^{-1}$$

(c) (i) What is meant by the terms overtones and beats? (03marks)

Overtone is a note of higher frequency than the fundamental frequency for a particular instrument.

Beats are periodic rise and fall in intensity of sound heard when two notes of nearly equal frequencies and similar amplitudes are sounded together.

(xxxi) State two uses of beats (02marks)

- Measurements of frequency of a note
- Tuning a musical instrument to a given note

(xxxii) A tube 1m long closed at one end has its lowest resonance frequency at 86.2Hz.

With a tube of identical dimensions but open at both ends, the first resonance occurs at 171Hz.

Calculate the speed of sound and the end correction. (06marks)

For closed pipe; $L + c = \frac{\lambda}{4} \Rightarrow \lambda = 4(L + c)$

Since $f = \frac{v}{\lambda}$
 $86.2 = \frac{v}{4(L + c)} \dots\dots\dots (i)$

For open pipe; $L + 2c = \frac{\lambda}{2} \Rightarrow \lambda = 2(L + c)$

$171 = \frac{v}{2(L + c)} \dots\dots\dots (ii)$

$L = 1\text{m}$ and dividing (i) by equation (ii)

$$\frac{86.2}{171} = \frac{2+4c}{4+4c}; c = 8.25 \times 10^{-3}\text{m}$$

Substituting c in equation (i)

$$v = 4 \times 86.2 (1 + 8.25 \times 10^{-3}) \text{ m} = 347.6 \text{ ms}^{-1}$$

30. (a)(i) State the superposition principle as applied to wave motion. (01mark)

When two waves meet in a medium, the resultant displacement is the sum of the displacements due to the individual waves.

(ii) What is meant by optical path? (01mark)

Optical path is the length in a medium that maintains the same number of waves as a given length in a vacuum.

Or

It is the product of the refractive index of a medium and the geometrical path length in air or vacuum.

- (b) (i) state the conditions which must be satisfied in order to observe an interference pattern due to two waves (02marks)

For observable interference pattern, the source should have equal amplitude and constant phase relationship.

The colors/source should be close to one another.

- (xxxiii) Explain why an oil film on a water surface appears to be colored. (04marks)

Colors on an oil film on water are due to interference of light.

When light from the sky reaches the oil film, it is partly reflected and partly refracted.

The refracted light is dispersed into colors is totally internally reflected on oil-water boundary.

The two reflected waves superpose when they meet.

The colors for the waves that meet in phase are seen while those that meet out of phase are missing.

- (c)

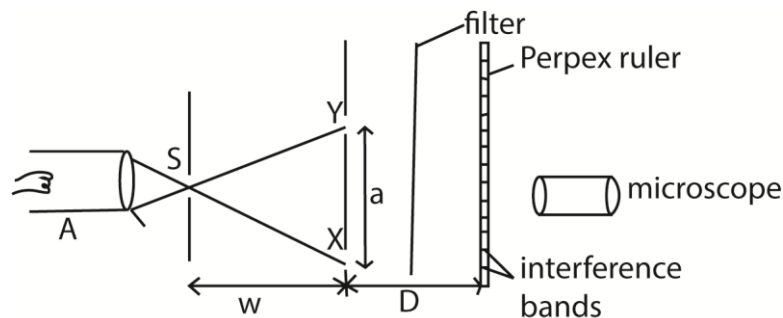

The figure above shows an experiment set up to demonstrate Young's interference fringes.

Explain what is observed when the

- (i) Slit X is covered. (02marks)

Interference patterns disappear and uniform illumination is observed on the screen. Since there is only one source, interference does not take place.

- (ii) Slit S is widened (02marks)

The bands gradually disappear. This is equivalent to many slits causing overlap and hence uniform illumination.

- (iii) Separation, a , of the slits X and Y is reduced keeping w fixed. (02marks)

The separation of fringes increase

Separation $y = \frac{\lambda D}{a}$ where a is the separation of slits. Thus $y \propto \frac{1}{a}$

- (iv) Distance, w , is reduced. (02 marks)

The separation of the fringes remain the same but the fringes become brighter. The smaller the distance the greater the intensity of light.

- (c) Monochromatic light of wavelength 600nm is incident normally on a plane diffraction grating which has 500 lines per mm. calculate the

- (i) Number of maxima observed

$$\lambda = 600\text{nm} = 600 \times 10^{-9}\text{m} = 6.0 \times 10^{-7}\text{m}$$

$$d = \frac{1}{500 \times 10^3} = 2 \times 10^{-6} \text{ m}$$

$$\text{First order } n_{\max} = \frac{d}{\lambda} = \frac{2 \times 10^{-6}}{6 \times 10^{-7}} = 3.3$$

$$n_{\max} = 3$$

(ii) Angular position of the first diffraction maximum (02marks)

$$d \sin \theta = n \lambda$$

$$\sin \theta = \frac{\lambda}{d} = \frac{6 \times 10^{-7}}{2 \times 10^{-6}} = 0.3$$

$$\theta = 17^\circ$$

31. (a) Distinguish between progressive and stationary waves. (04marks)

Progressive wave	Stationary wave
<ul style="list-style-type: none"> - There is energy flow along the wave - Vibrations are the same amplitude and same frequency - Phase of vibration changes for different points along the wave - Particles in phase are $n\lambda$ apart, $n = 1, 2, 3$ 	<ul style="list-style-type: none"> - No energy flow - Amplitudes different and depend on position along the wave - Some points are permanently fixed - Particles at distance $\frac{2n\lambda}{2}$ apart are in phase

(b) Briefly describe an experiment to show that a wire under tension can vibrate with more than one frequency.

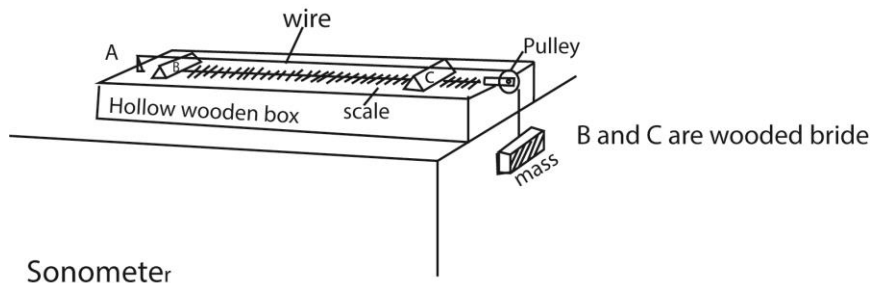

Sonometer

- The wooden bridges B and C vary the effective length of the wire, L.
- Constant tension in the wire is maintained by the fixed mass
- A paper rider is placed on the wire in the middle of BC and a sounding fork placed near it.
- The position of the bridge C is varied until sound is heard.
- The distance between the bridges L and the frequency, f , of the tuning fork is noted.
- The procedure is repeated for various tuning forks and values of L, f and $\frac{1}{L}$ are tabulated
- A plot of f against $\frac{1}{L}$ gives a straight line showing that the frequency of vibration of the wire is inversely proportional to length. I.e. frequency increases as length decreases.

(c) A uniform wire of length 1.00m and mass 2.0×10^{-2} kg is stretched between two fixed points. The tension in the wire is 200N. The wire is plucked in the middle and released. Calculate the

(i) Speed of the transverse waves. (03marks)

$$L=1.0\text{m}, m = 2.0 \times 10^{-2}\text{kg. } T= 200\text{N}$$

$$V = \sqrt{\frac{T}{m}} = \sqrt{\frac{200}{2 \times 10^{-2}}} = 100\text{ms}^{-1}.$$

(ii) Frequency of the fundamental note (03marks)

$$\lambda = 2L \text{ and } V = f\lambda$$

$$f = \frac{V}{\lambda} = \frac{100}{2 \times 1} = 50\text{Hz}$$

(d) (i) Explain how beats are formed. (02 marks)

When two notes of nearly equal frequencies are sounded together. At some instance waves from both sources arrive at some place in phase, reinforce and produce loud sound. At another instant, compression from one source arrive together with rarefaction from another and low sound or no sound at all is heard. The periodic rise and fall in loudness of sound is referred to as beats.

(xxxiv) Derive an expression for the beats frequency. (03marks)

Let f_1 and f_2 be the frequencies of the two notes. Suppose notes of frequency f_1 make one cycle more than the other in time T . Number of cycles of f_1 is f_1T and that of f_2 is f_2T in time T .

$$f_1T - f_2T = 1$$

$$(f_1 - f_2)T = 1$$

$$(f_1 - f_2) = \frac{1}{T} = f$$

Therefore beat frequency = $(f_1 - f_2)$

32. (a) Distinguish between longitudinal and transverse waves (02marks)

In transverse waves, the vibrations occur in a direction perpendicular to the wave while in longitudinal wave, the vibrations occur along the direction of a wave.

(b)(i) Describe the method of producing plane polarized light by reflection. (02marks)

unpolarized light

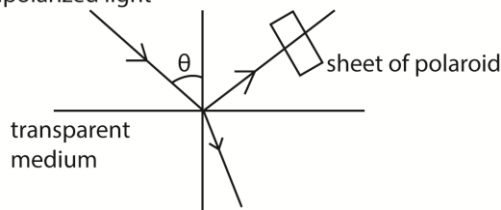

- A narrow beam of unpolarized light is made incident on transparent medium.
- The reflected light is observed through a Polaroid.
- The angle of incidence is varied
- At each angle of incidence, the polaroid is rotated about the axis along the light incident on it
- At one angle of incidence, the light gets cut off the observer as the Polaroid is rotated.
- The reflected ray is now completely polarized.

(iii) Mention two practical application of plane polarized light and describe one of them. (04marks)

- Reduce glare
- Measuring the concentration of sugars
- Holography
- Liquid crystal display

(c)(i) State the conditions necessary for formation of standing waves. (02marks)

When two wave trains of the same speed, same frequency and equal amplitude are moving in opposite direction

(ii) A Uniform tube, 50cm long is filled with water and vibrating tuning fork of frequency 512 Hz is sounded and held above it.

When the level of water is gradually lowered, the air column resonates with the tuning fork when the length is 12cm and again when it is 43.3cm.

Estimate the lowest frequency to which the air in the tube could resonate if the tube were empty.

Solution

$L = 50\text{cm} = 0.5\text{m}$; $f = 512\text{Hz}$, for $L_1 = 12\text{cm} = 0.12\text{m}$ and $L_2 = 43.3\text{cm} = 0.433\text{m}$

Now $L_1 + c = \frac{\lambda}{4}$ (i)

$L_2 + c = \frac{3\lambda}{4}$ (ii)

$L_2 - L_1 = \frac{\lambda}{2}$

$\lambda = 2(L_2 - L_1) = 2(43.3 - 12) = 62.6\text{cm} = 0.626\text{m}$

also, $v = f\lambda = 512 \times 0.626 = 320.5\text{ms}^{-1}$.

By substituting in eqn. (i)

$12 + c = \frac{0.626}{4}$

$c = 0.0365\text{cm}$

For open ended pipe, $f_0 = \frac{u}{\lambda} = \frac{u}{2(L+2c)} = \frac{320.2}{2(0.5+2 \times 0.0365)} = 280\text{Hz}$

For closed ended pipe, $f_0 = \frac{v}{\lambda} = \frac{v}{4(L+c)} = \frac{320.2}{4(0.5+ 0.0365)} = 149.3\text{Hz}$

33. (a) (i) What is meant by polarized light

Polarized light is one which is transmitted by vibrations in only one particular plane

(ii) Describe how plane polarized light can be produced (02marks)

- **Selective absorption:** a sheet of Polaroid is placed with its plane perpendicular to the direction of light rays. Only light vibrations of a particular orientation to the axes of the crystal are transmitted.
- **Reflection:** unpolarized light is made incident on the surface of glass or water at a certain angle such that reflected light is perpendicular to refracted light. The reflected light is totally polarized.

- Double reflection: when unpolarized light is incident on a crystal of calcite, it is split into two rays called ordinary and extraordinary. The two rays are plane polarized perpendicular to each other.

(iii) Sketch the time variation of electric and magnetic vectors in plane polarized light.

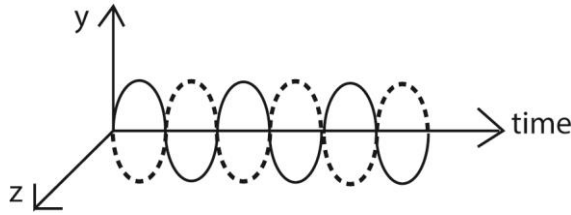

(b) Two coherent sources a distance, S , apart produce light of wavelength λ which overlap at a point on a screen at distance D from the sources to form interference pattern.

(i) What is meant by coherent sources? (02marks)

Two sources are said to be coherent when they have the same frequency and nearly the same amplitude, their vibrations are always in phase with each other.

(ii) Show that fringe width, ω , is given by $\omega = \frac{\lambda D}{S}$ (04marks)

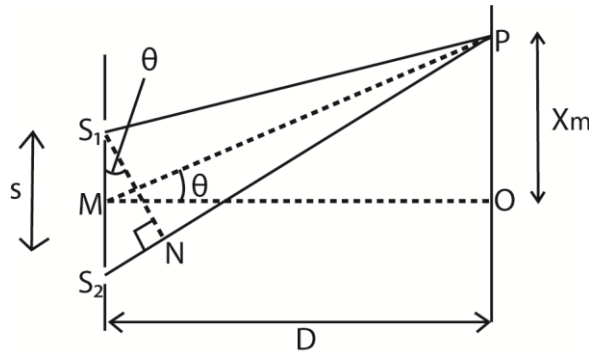

Let P be the position of the m^{th} bright fringes, the

$$S_2P - S_1P = m\lambda \dots\dots\dots (i)$$

The path difference between the waves arriving at P from S_1 and S_2 is

$$S_2N = S_2P - S_1P \dots\dots\dots (ii)$$

Since S_1S_2 is very small, and $PM \gg S_1S_2$ is nearly perpendicular to S_2P such that

$$S_2N \approx S \sin \theta$$

For small values of θ , $\sin \theta \approx \tan \theta = \frac{X_m}{D}$

$$\text{Hence } S_2N \approx \frac{SX_m}{D} \dots\dots\dots (iii)$$

From eqn. (i), (ii) and (iii)

$$m\lambda = \frac{SX_m}{D}$$

From $(m-1)^{\text{th}}$ bright fringe, $X_{m-1} = \frac{(m-1)\lambda D}{S}$

\therefore Fringe width $X_m - X_{m-1} = \frac{\lambda D}{S}$

- (iii) If $\lambda = 5.46 \times 10^{-7}\text{m}$, $S = 5 \times 10^{-5}\text{m}$ and $D = 0.3\text{m}$, find the angular position of the first dark fringe on the screen. (04marks)

For dark fringe, $X_m = \left(\frac{2m-1}{2}\right) \frac{\lambda D}{S}$

1st dark fringe $X_1 = \frac{0.5 \times 5.46 \times 10^{-7} \times 0.3}{5 \times 10^{-5}}$

But angular position $\theta = \frac{X_m}{D} = \frac{0.5 \times 5.46 \times 10^{-7}}{5 \times 10^{-5}} = 5.46 \times 10^{-3} \text{ rad or } 0.312^\circ$.

- (c) (i) What is meant by diffraction of light? (02marks)

Diffraction is the spreading of light beyond its geometrical shadows leading to interference.

- (xxv) Light of wavelength $6 \times 10^{-7}\text{m}$ is incident on diffraction grating with 500 lines per cm. find the diffraction angle for the first order image. (03marks)

$$\lambda = 6 \times 10^{-7}\text{m}; d = \frac{10 \times 10^{-3}}{500} = 2 \times 10^{-5}\text{m}$$

$$d \sin \theta = m \lambda$$

$$\text{since } \theta \text{ is very small, } \theta = \frac{m \lambda}{d}$$

$$\text{for 1}^{\text{st}} \text{ order image } \theta = \frac{\lambda}{d} = \frac{6 \times 10^{-7}}{2 \times 10^{-5}} = 3 \times 10^{-2} \text{ rad} = 1.72^\circ$$

34. (a)(i) Distinguish between longitudinal and transverse waves (02marks)

Transverse waves are those which propagate by vibrations perpendicular to the direction of travel of the wave. While in longitudinal waves the vibrations occur in the same direction as the direction of travel of the wave.

- (ii) Define wavelength of a wave. (01mark)

Wavelength of a wave is the distance between two successive particles in phase. Or the distance between two successive crests or trough.

- (b) Describe with the aid of a diagram, an experiment to show the fundamental frequency varies with the tension in a given wire.

A sonometer below is used.

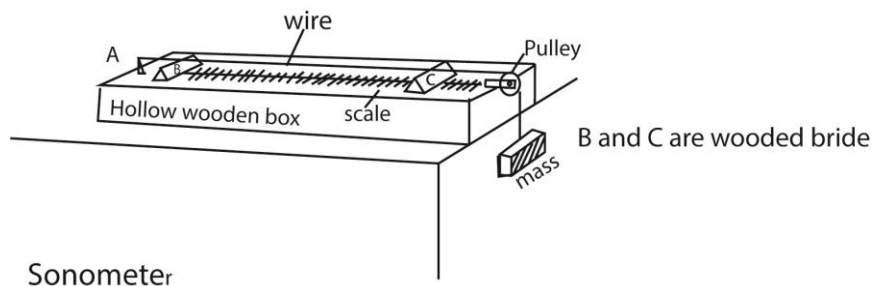

The length L between the bridges is fixed.

A suitable mass, m , is attached to the free end of the wire.

The wire is plucked in the middle and a tuning fork of known frequency, f , is sounded

The mass m corresponding to the frequency, f , are recorded in the table including values of f^2 .

The procedure is repeated for different values of f .

A graph of f^2 against m is plotted.

A straight line graph is obtained through the origin, implying that $f^2 \propto m$

$$\text{But } m = \frac{T}{g}$$

$$\therefore f = \sqrt{\frac{T}{g}} \text{ thus increase in tension, } T, \text{ increases the frequency, } f, \text{ of the wire.}$$

(c) A sound wave propagating in the x -direction is given by the equation

$$y = 2 \times 10^{-7} \sin(\sin 8000t - 25x) \text{ meters. Find}$$

(i) Amplitude (01mark)

$$= 2 \times 10^{-7} \text{m}$$

(ii) The speed of the wave (05marks)

$$\text{Compare with } y = a \sin 2\pi \left(ft - \frac{x}{\lambda} \right)$$

$$25x = \frac{2\pi x}{\lambda} \text{ or } \lambda = \frac{2\pi}{25}$$

$$\text{Also } 2\pi ft = 8000t$$

$$f = \frac{8000}{2\pi}$$

$$v = f\lambda = \frac{8000}{2\pi} \times \frac{2\pi}{25} = 320 \text{ms}^{-1}$$

(d) Explain why the amplitude of a wave goes on decreasing as the distance from the source increases

As the wave progresses, energy is continuously absorbed by the medium

35. (a) Define wavelength of a wave (01mark)

This is the distance between two successive crests or trough.

(e) A source of sounding moving with velocity u_s , approaches an observer moving with velocity u_o in the same direction, derive an expression for frequency of sound heard by the observer. (05mark)

f -waves occupy a distance $c - u_s$; where c is the speed of sound in air.

$$\text{Apparent wavelength of the wave} = \frac{c - u_s}{f}$$

$$\text{Speed of waves relative to observer, } v_a = c - u_0$$

$$\text{Apparent frequency, } f_a = \frac{v_a}{\lambda_a} = \frac{c - u_0}{\frac{c - u_s}{f}} = \left(\frac{c - u_0}{c - u_s} \right) f$$

- (f) Explain what happens to the pitch of the sound heard by the observer in (b) above when
- (i) Observer moves faster than the source (02marks)

Pitch depend on frequency as experienced by the listener, i.e. high frequency produces a high pitched note and the vice versa.

$$\text{From } f_a = \frac{v_a}{\lambda_a} = \left(\frac{c - u_0}{c - u_s} \right) f$$

$$\text{When } u_0 > u_s; (c - u_0) < (c - u_s)$$

$$\text{Hence } f_a < f$$

Therefore the apparent frequency is low and thus the pitch of sound will be detected.

- (ii) Observer's velocity is equal to that of the sound. (02marks)
 If $u_0 = c$, then $f_a = 0\text{Hz}$ or no sound is detected by the observer.

- (g) State and explain one application of Doppler Effect. (05marks)

Used in radar speed trap.

Microwaves of frequency f_0 from stationary radar are sent directly towards a motor vehicle moving with a speed, v .

The microwaves reflected from moving car are detected by the radar set.

The reflected signal mixes with the transmitted signal to obtain beats.

The beat frequency of f which is equal to the difference between the frequency of the received and transmitted signal is determined.

$$\text{The speed of the vehicle is determined from, } v = \frac{\Delta f}{2f_0}$$

Measurement of plasma temperature

The broadening $\Delta\lambda$ of a spectral line emitted by the plasma is determined using a diffraction grating

$$\frac{\Delta\lambda}{\lambda} = \frac{2v}{c}$$

Assuming $v = v_{r.m.s}$ then $\frac{1}{2} M v^2 = \frac{3}{2} RT$ where M is the molar mass.

$$v = \left(\frac{3RT}{M} \right)^{\frac{1}{2}}$$

$$T = \frac{M}{12R} \left(\frac{\Delta\lambda}{\lambda_0} \right)^2 c^2$$

Measurement of the speed of star

The wavelength, λ , of light emitted by the star is measured.

The absorption spectrum of an element known to be in the star is examined.

The wavelength, λ' , of the missing line is measured. If u_s is the speed of the star, the Doppler Effect shift = $(\lambda' - \lambda)$

$$\text{Thus, } \left| \frac{\lambda' - \lambda}{\lambda} \right| = \frac{u_s}{c}$$

$$u_s = c \left| \frac{\lambda' - \lambda}{\lambda} \right|$$

(h) The wire of the guitar of length 50cm and mass per meter 1.5×10^{-3} kg is under tension of 173.4N. If it is plucked at the middle point, find the

(i) Frequency (03marks)

$$f = \frac{1}{2L} \sqrt{\frac{T}{\mu}} = \frac{1}{2 \times 0.5} \sqrt{\frac{173.4}{1.5 \times 10^{-3}}} = 340\text{Hz}$$

(ii) The wavelength of the fundamental note (02marks)

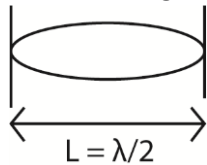

$$\lambda = 2L = 2 \times 0.5 = 1.0\text{m}$$

36. (a) (i) What is meant by interference of waves? (02marks)

Interference of waves is the superposition of waves from two coherent sources to produce alternate regions of maximum and minimum intensity.

(ii) State conditions for observation of an interference pattern (02)

- Sources must be coherent
- Amplitudes must be nearly equal
- The sources must be close to each other.

(iii) Describe how interference can be used to test for flatness of the surface.

The surface under test is made to form an air-wedge with a plane glass surface of standard smoothness.

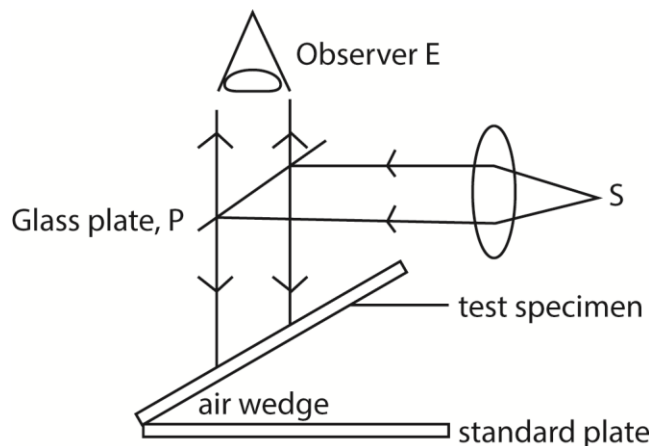

A parallel beam of monochromatic light from source, S, is reflected from a glass plate, P to fall normally to the air wedge.

Light reflected by the air wedge is observed.

Irregularity in the surface of test specimen will show up as irregularity in the fringe pattern.

- (i) Describe with the use of a diagram, how the wavelength of monochromatic light can be measured using Young's double slit method (05marks)

Monochromatic light from a small lamp is made to illuminate the double slit A and B as shown below.

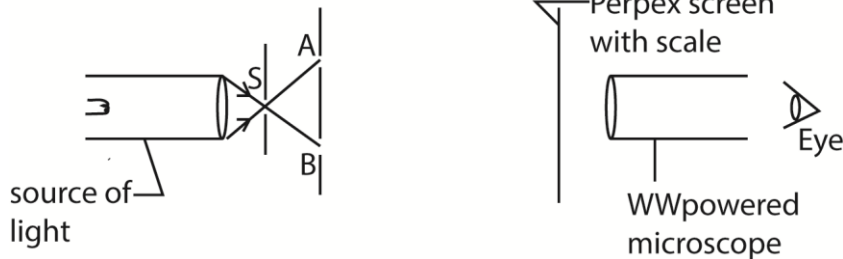

The fringe separation, y , is found by traversing a known number of fringes using a microscope which is moved along the perpex ruler; (note that fringes are equally spaced).

The slit separation a is measured using a travelling microscope.

The wavelength of light used; $\lambda = \frac{ay}{d}$

- (j) Two microscope slides are in contact at one end and are separated by a thin piece of paper at the other end. Monochromatic light is directed normally on the wedge.

- (i) What types of fringes will be observed? (02marks)

Alternate bright and dark fringes that are equally spaced and parallel to the line along which slides make contact will be observed.

- (ii) Explain what will be observed if a liquid is introduced between the slides (02mark)

From refractive index, $n_l = \frac{c}{v_{liquid}} = \frac{f\lambda_{air}}{f\lambda_{liquid}}$

$$\therefore \lambda_{liquid} = \frac{f\lambda_{air}}{n_{liquid}}$$

where c and v_{liquid} are velocities of light in air and liquid and λ_{air} and λ_{liquid} are wavelength of light in air and liquid. Respectively.

Fringe separation, $y = \frac{\lambda_{air}}{2\tan\theta}$ where θ is the wedge angle.

The new fringe separation, $y' = \frac{\lambda_{liquid}}{2\tan\theta} = \frac{\lambda_{air}}{2n\tan\theta}$

Hence fringe separation is reduced by a factor of n in relation to that of air wedge.

- (k) When monochromatic light of wavelength 5.8×10^{-7} m is incident normally on a transmission grating. The second order diffraction line is observed at an angle of 27° . How many lines per centimeter does the grating have? (04marks)

From $d\sin\theta = n\lambda$, where d is the grating spacing.

$$d = \frac{2 \times 5.8 \times 10^{-7}}{\sin 27} = 2.56 \times 10^{-6} \text{ m}$$

$$\text{Number of line spacing per cm} = \frac{1 \times 10^{-2}}{d} = \frac{1 \times 10^{-2}}{2.56 \times 10^{-6}} = 3.91 \times 10^3 \text{ lines per cm}$$

37. (a) Why is light referred to as a transverse wave? (01mark)

Light is referred as transverse waves because the vibrations of the magnetic and electric vectors are perpendicular to the direction of propagation of light wave.

(l) (i) State Huygens' Principle. (02marks)

(xxxvi) Use Huygens' Principle to show that refractive index of medium 2 relative to medium 1 is given by

${}_1n_2 = \frac{v_1}{v_2}$ where v_1 and v_2 are the velocities of light in medium 1 and 2 respectively. (07marks)

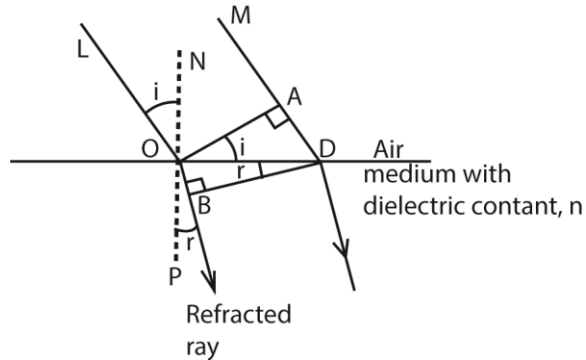

In figure above, each point between O, D becomes a new centre of disturbance as the wave front advances to the surface of the medium, and the wave front changes in direction when the disturbance enters the medium.

Suppose that t is the time taken by the light to travel from A to D. The disturbance from O travels a distance OB, or v_2t , in the medium in a time t , where v is the velocity of light in medium.

At the end of the time t , the wave fronts in the medium from the other secondary centres between O, D reach the surfaces of spheres to each of which DB is a tangent.

Thus DB is the new wave front in the water, and the ray OB which is normal to the wave front is consequently the refracted ray.

Since c is the velocity of light in air, $AD = v_1t$.

Now

$$\frac{\sin i}{\sin r} = \frac{\sin \angle LON}{\sin \angle BOP} = \frac{\sin \angle AOB}{\sin \angle ODB}$$

$${}_1n_2 = \frac{\sin i}{\sin r} = \frac{AD}{OD} \div \frac{OB}{OD} = \frac{AD}{OD} \times \frac{OD}{OB} = \frac{AD}{OB} = \frac{v_1t}{v_2t} = \frac{v_1}{v_2}$$

(c) (i) What is meant by division of wave fronts as applied to interference of waves (02marks)

This a process of getting two coherent waves from a single wave front

(ii) Two slits A and B are separated by a distance d and illuminated with light of wavelength, λ .

Derive an expression for separation between successive fringes on a screen placed a distance D from slits, (05marks)

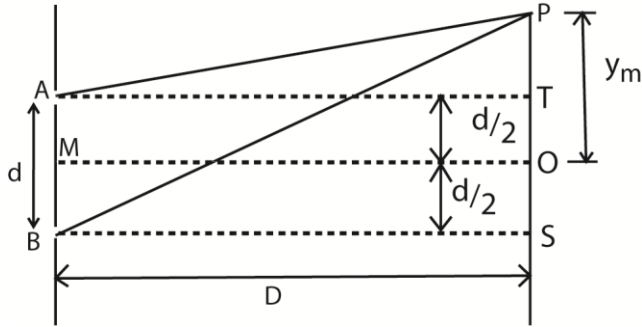

Suppose waves from A and B superpose at P to form a bright fringe

For triangle ATP; $AP^2 = AT^2 + TP^2$

$$\begin{aligned}
 &= D^2 + \left(y_m - \frac{d}{2}\right)^2 \\
 &= D^2 + y_m^2 - y_m d + \frac{d^2}{4} \dots\dots\dots (i)
 \end{aligned}$$

For triangle BSP; $BP^2 = BS^2 + SP^2$

$$\begin{aligned}
 &= D^2 + \left(y_m + \frac{d}{2}\right)^2 \\
 &= D^2 + y_m^2 + y_m d + \frac{d^2}{4} \dots\dots\dots (ii)
 \end{aligned}$$

Eqn. (ii) – eqn. (i); $BP^2 - AP^2 = 2y_m d$

$$(BP + AP)(BP - AP) = 2y_m d$$

Since $d \ll D$, $BP \approx AP \approx OM = D$

$$\text{Thus, } BP + AP = 2D$$

$$\text{Then, } 2D(BP - AP) = 2y_m d$$

For bright fringe, $BP - AP = m\lambda$

$$2Dm\lambda = 2y_m d$$

$$y_m = \frac{m\lambda D}{d}$$

for the next bright fringe $(m + 1)^{\text{th}}$

$$y_{m+1} = \frac{(m+1)\lambda D}{d}$$

$$y_{m+1} - y_m = \frac{\lambda D}{d}$$

\therefore Fringe separation, $y = \frac{\lambda D}{d}$

Alternatively

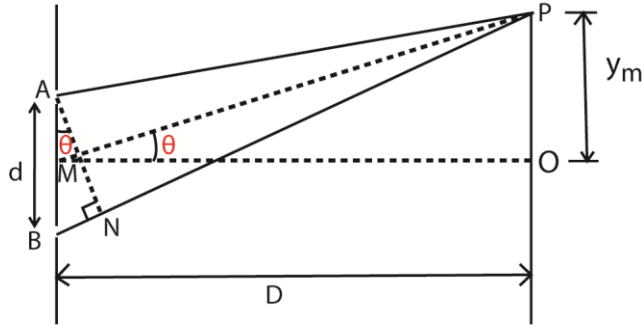

A and B are coherent sources.

Suppose waves from A and B superpose at P to form bright fringe

Path difference, $BN = BP - AP = d \sin \theta$

For $D \gg d$, θ is small that $\sin \theta = d \tan \theta$

$$\Rightarrow BN = d \tan \theta = \frac{dy_m}{D}$$

For the m^{th} bright fringe, $BN = m\lambda$, where λ is the wavelength

$$\Rightarrow \frac{dy_m}{D} = m\lambda$$

$$y_m = \frac{m\lambda D}{d}$$

For $(m + 1)^{\text{th}}$ bright fringe, $\frac{dy_{m+1}}{D} = (m + 1)\lambda$

$$y_{m+1} = \frac{(m+1)\lambda D}{d}$$

Fringe separation, $y = y_{(m+1)} - y_m = \frac{(m+1)\lambda D}{d} - \frac{m\lambda D}{d} = \frac{\lambda D}{d}$

- (iii) In Young's double slit experiment, the 8th bright fringe is formed 5mm away from the center fringe system when the wavelength of light is $6.2 \times 10^{-7}\text{m}$. Calculate the separation of the two slits if the distance from slits to the screen is 80cm.

$$y_8 - y_0 = 8 \frac{D\lambda}{d}$$

$$5 \times 10^{-3} = 8 \left(\frac{0.8 \times 6.2 \times 10^{-7}}{d} \right)$$

$$d = 8 \left(\frac{0.8 \times 6.2 \times 10^{-7}}{5 \times 10^{-3}} \right) = 7.94 \times 10^{-4}\text{m}$$

38. (a) Explain the term interference of light (04marks)

Interference of light is superposition of waves from coherent sources leading to alternate regions of maximum and minimum intensity.

If the path difference between the waves is an integral multiple of wavelength, constructive interference occurs (maximum intensity).

If the path difference between waves is an odd multiple of half the wavelength, destructive interference occurs (minimum intensity).

(b)

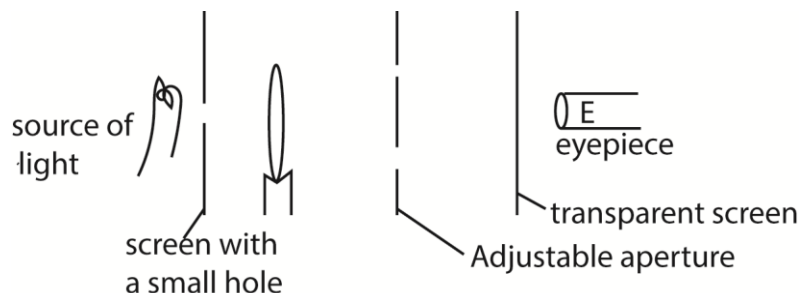

In the experiment to observe diffraction, the set up in figure 2 is used.

(i) Describe what you would see at E if the aperture is gradually reduced (04mark)

When the slit separation is large ($a \gg \lambda$) a bright band of approximately the same width as the slit is observed

As the slit width is reduced so that $a \approx \lambda$, a diffraction pattern is observed. A central white band having dark bands on either side is obtained. The dark bands have colored fringes running from blue to red; blue being nearest to the direct position.

As the slit width is reduced further, $a \ll \lambda$, the central bright band widens and extends well into the geometrical shadows of the slit.

When the slit finally close, no light passes through.

(ii) Explain your observation in (b)(i) above.

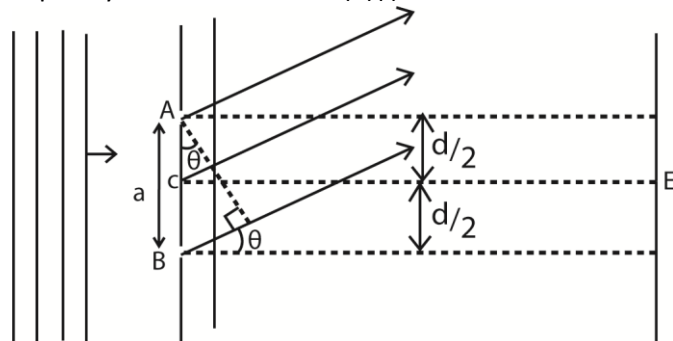

Imagine the slit to consist of stripes of equal width parallel to the length of the slit.

Let c be the length of the slit.

The first dark band on either side of central bright band are formed at an angle θ to the incident beam.

The path difference for the secondary wavelets from the strips just below A and strip just below c is $\frac{\lambda}{2}$

Destructive interference will occur from this pair of strips since the crest from one strip reaches the observer with the trough from the other. This happens for all pairs of corresponding strips in AC and CB because the same path difference exists. The central

bright band is formed at E. wavelets from all the imaginary strips in the slits arrive in phase.

$$\text{For first minimum, } CD = \frac{a}{2} \sin \theta = \frac{\lambda}{2}$$

$$\sin \theta = \frac{\lambda}{a}$$

For white light, this condition occurs slightly different angles for component colors. This accounts for colored fringes at edges of the dark band.

(c) A diffraction grating has 550 lines per mm. when illuminated normally by monochromatic light, the angle between the central maximum and the first maximum is 19.1° . Find the

(i) wavelength of light (04marks)

$$N\lambda = d \sin \theta$$

$$\lambda = \frac{1 \times 10^{-3}}{550} \times \sin 19.1 = 5.95 \times 10^{-7} \text{ m}$$

(ii) number of diffraction maxima obtained (02marks)

$$n_{\max} = \frac{d}{\lambda} = \frac{1 \times 10^{-3}}{5.95 \times 10^{-7}} = 3$$

(d) State two uses of diffraction of light. (02marks)

- Measurements of wavelength of light using diffraction grating
- For holography (making 3-dimensional images)

39. (a) (i) Distinguish between free and damped oscillation (02marks)

In free oscillation, the energy and amplitude are constant while in damped oscillation, the total energy and amplitude decrease with time.

(ii) Describe how the amplitude of a forced oscillation builds up to a constant value.

A constant amplitude is maintained by a periodic input of force to an oscillating system.

The periodic force compensate the energy lost by oscillation to the system.

(b) The displacement in meters of a plane progressive wave is given by the equation

$$y = 0.2 \sin \pi \left(200t - \frac{20x}{17} \right). \text{ Find}$$

(i) Wavelength and (02marks)

$$\text{Compare } y = 0.2 \sin \pi \left(200t - \frac{20x}{17} \right) \text{ with } y = a \sin \left(\frac{2\pi t}{T} - \frac{2\pi x}{\lambda} \right).$$

$$\frac{20\pi x}{17} = \frac{2\pi x}{\lambda}; \lambda = 1.7 \text{ m}$$

(ii) Speed of the wave (02marks)

$$\frac{2\pi t}{T} = 200\pi t \text{ but } T = \frac{\lambda}{v}$$

$$\frac{2}{\lambda} = 200$$

$$v = \frac{200\lambda}{2} = \frac{200 \times 1.7}{2} = 170 \text{ m s}^{-1}$$

(c)(i) Explain the occurrence of beats in sound (03marks)

Beats are the periodic variation in intensity of sound heard when two notes of nearly equal frequency and amplitude moving with the same velocity overlap. When notes arrive in phase to an observer, they reinforce and produce louder notes. Where the notes arrive to the observer out of phase, no sound is heard.

- (ii) Two tuning forks X and Y are sounded together to produce beats of frequency 8Hz. Fork X has a known frequency of 512Hz.

When Y is loaded with a small plasticine, beats at frequency of 2Hz are heard when the two tuning forks are sounded together.

Calculate the frequency of Y when unloaded. (03marks)

$$f_x - f_y = 8 \quad \text{or} \quad f_y - f_x = 8$$

Given $f_x = 512\text{Hz}$

$$f_y = 512 - 8 = 504\text{Hz} \quad \text{or} \quad f_y = 520\text{Hz}$$

loading y reduces the frequency of y

$$\therefore \text{Frequency, } f_y = 520\text{Hz}$$

- (d)(i) What is Doppler's Effect? (01mark)

Doppler Effect is the apparent change in the frequency of radiant energy or sound that occurs as a result of the relative motion of the source and the observer.

- (ii) A car sounds its horn as it travels at a steady speed of 15ms^{-1} along a straight road between two stationary observers A and B. The observer A hears a frequency of 538Hz while B hears a lower frequency.

Calculate the frequency heard by B, assuming the speed of sound in air is 340ms^{-1} .

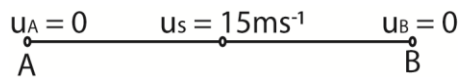

$$\lambda'_A = \frac{v - u_s}{f} \quad \text{and} \quad f'_A = \frac{vf}{v - u_s}$$

Substituting $v = 340\text{ms}^{-1}$, $u_s = 15\text{ms}^{-1}$ and $f'_A = 538\text{Hz}$

$$f = \frac{f'_A x (v - u_s)}{v} = \frac{538 (340 - 15)}{340} = 514\text{Hz}$$

$$\text{also, } \lambda'_B = \frac{v + u_s}{f} \quad \text{and} \quad f'_B = \frac{vf}{v + u_s} = \frac{340 \times 514}{(340 + 15)} = 492\text{Hz}$$

40. (a) (i) What is meant by interference and diffraction of light waves? (02marks)

Diffraction is the spreading of light beyond the geometrical shadow leading to interference pattern just beyond geometrical shadow.

- (ii) State the conditions of necessary for observing diffraction (01marks)

The dimensions of aperture should be comparable with wavelength of light.

- (c) (i) Derive the expression for fringe separation in Young's interference pattern in terms of the slit-separation, d , the distance, D , of the screen from the double slits and the wavelength, λ , of the light.

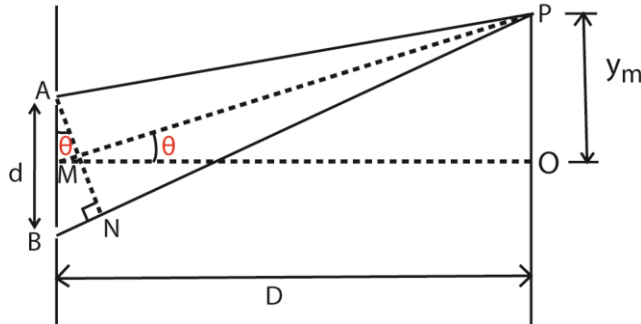

A and B are coherent sources.

Suppose waves from A and B superpose at P to form bright fringe

$$\text{Path difference, } BN = BP - AP = d \sin \theta$$

For $D \gg d$, θ is small that $\sin \theta = d \tan \theta$

$$\Rightarrow BN = d \tan \theta = \frac{dy_m}{D}$$

For the m^{th} bright fringe, $BN = m\lambda$, where λ is the wavelength

$$\Rightarrow \frac{dy_m}{D} = m\lambda$$

$$y_m = \frac{m\lambda D}{d}$$

For $(m + 1)^{\text{th}}$ bright fringe, $\frac{dy_{m+1}}{D} = (m + 1)\lambda$

$$y_{m+1} = \frac{(m+1)\lambda D}{d}$$

$$\text{Fringe separation, } y = y_{(m+1)} - y_m = \frac{(m+1)\lambda D}{d} - \frac{m\lambda D}{d} = \frac{\lambda D}{d}$$

- (d) Two slits of 0.5mm apart are placed at a distance of 1.0m from the screen. The slits are illuminated with light of wavelength 550nm. Calculate the distance between the fourth and second bright fringes of the interference pattern. (05marks)

$$x_2 = \frac{2\lambda D}{d} \text{ and } x_4 = \frac{4\lambda D}{d}$$

$$x_4 - x_2 = \frac{2\lambda D}{d}$$

Substituting $\lambda = 550 \times 10^{-9} \text{m}$, $d = 0.5 \times 10^{-3} \text{m}$ and $D = 1.0 \text{m}$

$$x_4 - x_2 = \frac{2 \times 550 \times 10^{-9} \times 1}{0.5 \times 10^{-3}} = 2.2 \times 10^{-3} \text{m}$$

- (e) A transmission diffraction grating of spacing, d , is illuminated normally with light of wavelength, λ .

- (i) Derive the condition for occurrence of diffraction maxima. (03marks)

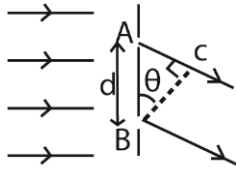

Path difference for between waves A and B = distance AC = $d \sin \theta$

For reinforcement (diffraction maxima) path difference = $n\lambda$ where $n = 1, 2, 3, \dots$

Therefore $d \sin \theta = n\lambda$

- (ii) Describe briefly the intensity distribution on a screen placed beyond the grating (02marks)

A central principal maxima is the most intense and the intensity decreases outwards on either side.

- (iii) What is the effect on the diffraction pattern of using a grating with a larger number of lines? (02marks)

Using a grating with a large number of lines reduces the slit separation, d , and the peaks become sharper.

41. (a) State the principle of superposition of waves (1mark)

The total displacement of any particle by waves is the sum of their individual's displacements.

- (f) Two loud speakers producing sound of the same frequency are placed 50m apart facing each other. An observer walks from one speaker to the other along the line of the speaker.

- (i) What does the observer hear? (2marks)

The observer hears alternate loud and soft sound. The loud and soft sounds come at equal distance along the observer's path.

- (ii) Explain the observation in (b)(i) (4marks)

The two waves superpose to form interference pattern. Loud sound is heard when the path difference of the waves is an integral even multiple of a half wavelength. The soft or no sound is formed when the path difference is an integral odd multiple of half a wavelength.

- (g) Describe with the aid of a diagram how you can determine the velocity of sound in air by a method which uses interference of sound. (6marks)

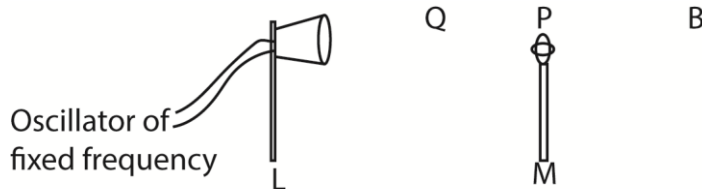

The loud speaker, L is connected to an oscillator of constant frequency, f .

A microphone, M is connected to the Y-plates of a cathode ray tube.

The microphone is moved away from B towards L until the amplitude of the wave on C.R.O is maximum.

The position P of the microphone is noted and distance BP is measured.

The microphone is move farther away from B to Q where another maximum amplitude of wave front is obtained. Distance BQ is measured and recorded.

The distance between two successive maxima $d = BQ - BP = \frac{\lambda}{2}$ where λ is the wavelength

Velocity of sound = $f\lambda = 2df$.

- (h) A progressive wave and stationary wave each has a frequency of 240Hz and speed of 80ms^{-1} .

Calculate

- (i) Phase difference between two vibrating points in progressive waves, which are 6cm apart. (04marks)

$$f = 240\text{Hz}, v = 80\text{ms}^{-1}$$

$$\text{Phase angle } \phi = \frac{2\pi x}{\lambda}$$

$$\text{Phase difference } \phi = \frac{2\pi x_1 - x_2}{\lambda}$$

$$\Delta\phi = \frac{2\pi\Delta x}{\lambda}$$

$$\Delta x = 6\text{cm} = 6 \times 10^{-2}\text{m}$$

$$\Rightarrow \Delta\phi = \frac{2\pi \times 6 \times 10^{-2}}{\lambda}$$

But $v = f\lambda$

$$\lambda = \frac{v}{f} = \frac{80}{240} = \frac{1}{3}\text{m}$$

$$\Rightarrow \Delta\phi = \frac{2\pi \times 6 \times 10^{-2}}{1/3} = 1.13 \text{ rad}$$

- (ii) Distance between nodes in stationary wave. (03marks)

$$\text{Distance between nodes} = \frac{\lambda}{2}$$

$$\text{But } \lambda = \frac{v}{f} = \frac{80}{240} = \frac{1}{3}\text{m}$$

$$\text{Hence distance between nodes} = \frac{1}{3} \div 2 = \frac{1}{6}\text{m or } 0.17\text{m}$$

42. (a) What is meant by coherent source of light? (03marks)

Coherent sources are sources with the same frequency and nearly the same amplitude and constant phase difference between them

- (i) (i) outline the principles of Young's double slit interference and derive the expression for fringe separation. (07marks)

The principles of Young's double slit interference

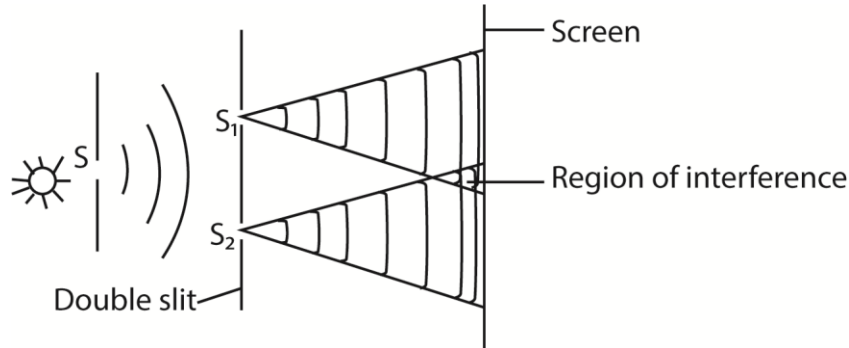

A wave from source, S, is incident on the double slits where division of wave front occurs. This makes S₁ and S₂ coherent sources, Waves S₁ and S₂ superpose and where a crest meets a crest or a trough meets a trough, maximum intensity is obtained. In between the maxima are points of minimum intensity.

Fringe separation

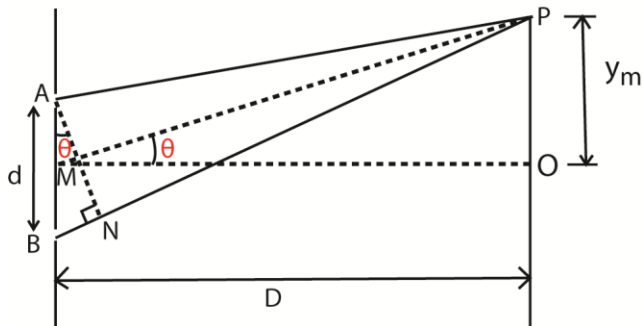

A and B are coherent sources.

Suppose waves from A and B superpose at P to form bright fringe

Path difference, $BN = BP - AP = d \sin \theta$

For $D \gg d$, θ is small that $\sin \theta = d \tan \theta$

$$\Rightarrow BN = d \tan \theta = \frac{d y_m}{D}$$

For the m^{th} bright fringe, $BN = m \lambda$, where λ is the wavelength

$$\Rightarrow \frac{d y_m}{D} = m \lambda$$

$$y_m = \frac{m \lambda D}{d}$$

For $(m + 1)^{\text{th}}$ bright fringe, $\frac{d y_{m+1}}{D} = (m + 1) \lambda$

$$y_{m+1} = \frac{(m+1) \lambda D}{d}$$

$$\text{Fringe separation, } y = y_{(m+1)} - y_m = \frac{(m+1)\lambda D}{d} - \frac{m\lambda D}{d} = \frac{\lambda D}{d}$$

- (xxxvii) What would be the effect of replacing monochromatic light by white light in Young's double slit experiment. (03marks)

When monochromatic light is replaced with white light colored fringes are observed with the central fringe appearing white.

The distinct fringes are followed by blurred fringes which are followed with uniform illumination

The blue fringes are nearest to the central fringe while the red fringe is farthest.

- (c) An air wedge is formed by placing two glass slides of length 5.0cm in contact at one end and a wire at the other end as shown in the figure below

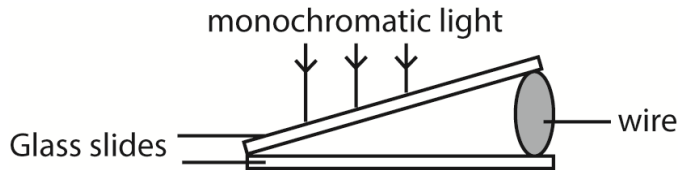

Viewing from vertically above, 10 dark fringes are observed to occupy a distance of 2.5mm when the slides are illuminated with light of wavelength 500nm.

- (i) Explain briefly how the fringes are formed. (03marks)
- Some of the light falling on the wedge is reflected upwards from the bottom of the top slide and some of that transmitted is reflected upwards from the top of the bottom slide.
 - The light reflected from the top surface of bottom slide undergoes a phase change of π equivalent to additional path difference of $\frac{\lambda}{2}$
 - The reflected waves train superpose and dark fringes are observed when the path difference = $n\lambda$ while a bright fringe is observed when the path difference = $\left(\frac{2n+1}{2}\right)\lambda$
- (ii) Determine the diameter of the wire. (04marks)
For the first 10 dark fringes, $L = 5.0\text{cm} = 5.0 \times 10^{-2}\text{m}$;

Solution

$$\text{Fringe separation} = \frac{2.5 \times 10^{-3}}{10} = 2.5 \times 10^{-4}\text{m}$$

$$\lambda = 500\text{nm} = 5 \times 10^{-7}\text{m}$$

$$\tan \theta = \frac{\lambda}{2y} = \frac{5 \times 10^{-7}}{2 \times 2.5 \times 10^{-4}} = 1 \times 10^{-3}$$

$$\theta = 1 \times 10^{-3} \text{ rad} = 0.06^\circ$$

A beat is the periodic rise and drop in intensity of sound heard when two notes of nearly equal frequency are sounded together.

Thank you so much

Compiled by Dr. Bbosa Science