



Dr. Bhasa Science

Sponsored by
The Science Foundation College
Uganda East Africa
Senior one to senior six

+256 778 633682 0753 143413

Based on, Best for Science

digitalteachers.co.ug



Nuture your dreams



SENIOR SIX TERM 2

TOPIC 5/5: Coordinate Geometry 2

Competency: The learner applies algebraic and geometric techniques to analyse spatial relationships applicable in real-world contexts.

Contents

Coordinate geometry 2	2
Conic section	2
Parabola	17
The Ellipse	27
The hyperbola	37
The rectangular hyperbola.....	40

Coordinate geometry 2

Conic section

The section is the circle, parabola, ellipse and hyperbola. They are called conic sections because they are the shapes one sees when he slices a double cone at various angles.

Mathematically a conic is a locus of points that move such that its distance from a fixed point (focus) bears a constant ratio (eccentricity, e) to its distance from a fixed line (directrix).

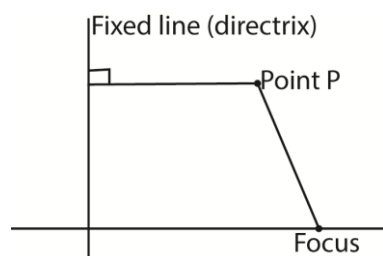

There are four different conics depending on the magnitude of the eccentricity, e :

When

- $e = 0$, it is a circle
- $e < 1$, it is an ellipse
- $e = 1$, it is a parabola
- $e > 1$ it is hyperbola

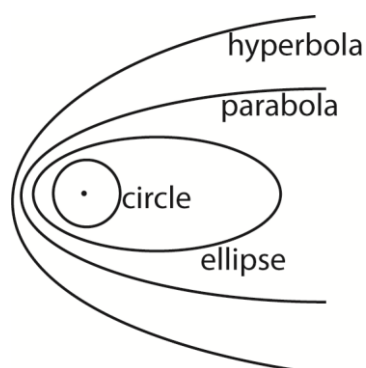

In a Cartesian coordinate system, a conic is a curve that has an equation of the second degree given in the form

$$ax^2 + 2hxy + by^2 + 2gx + 2gy + C = 0$$

Please find free notes, tests and marking guides of physics, chemistry, biology and mathematics from: digitalteachers.co.ug

Now when

- $a = b$ and $h = 0$, it is a circle
- $h^2 < ab$, it is an ellipse
- $h^2 = ab$, it is a parabola
- $h^2 > ab$, it is a hyperbola
- $a = -b$, it is a rectangular hyperbola

The circle

A circle is a locus of point that moves so that its from a fixed point is constant

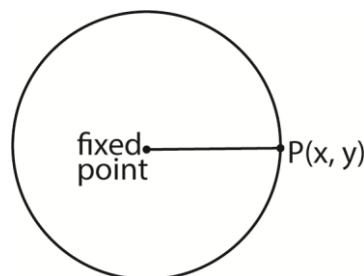

The fixed point is the **centre** of the circle and the constant distance is the **radius**.

Equation of a circle

There are several ways of obtaining the equation of the circle.

I. Given the radius and the centre.

- (a) The centre at the origin
Let $P(x, Y)$ be a point on the circumference of the circle

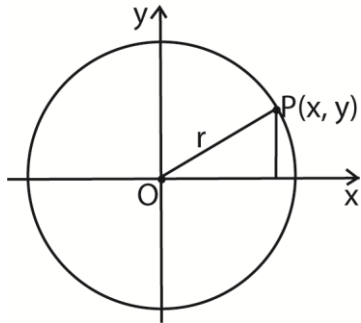

From Pythagoras theorem

$$(x - 0)^2 + (y - 0)^2 = r^2$$

$$x^2 + y^2 = r^2$$

(b) The centre at any point C(a, b)

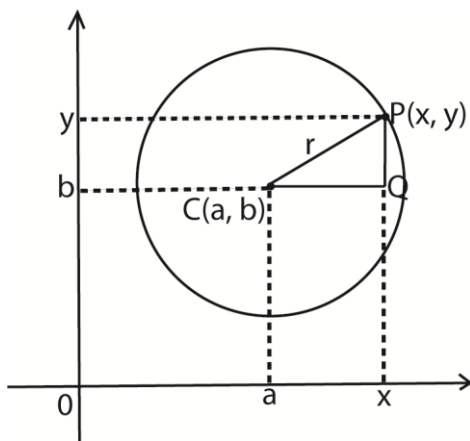

In the triangle CPQ

$$(x - a)^2 + (y - b)^2 = r^2 \dots\dots\dots(i)$$

$$x^2 - 2ax + a^2 + y^2 - 2by + b^2 = r^2$$

$$x^2 + y^2 - 2ax - 2by + a^2 + b^2 - r^2 = 0$$

$x^2 + y^2 + 2gx + 2fy + c = 0$ where $g = -a$, $f = -b$ and $c = a^2 + b^2 - r^2$ (a constant)

Equation (i) show a the equation of a circle is obtained given its centre and radius.

Equation (ii) represents the general equation of a circle with centre $(-g, -f)$ and radius,

$$r = \sqrt{g^2 + f^2 - c}$$

Example 1

(a) Find the equation of the circle with centre at

(i) origin and radius 5 units

Solution

Using general equation

$$(x - 0)^2 + (y - 0)^2 = 5^2$$

$$x^2 + y^2 = 25$$

(ii) (-1, 2) and radius 4 units

Solution

$$(x + 1)^2 + (y - 2)^2 = 4^2$$

$$x^2 + y^2 + 2x - 4y = 11$$

(iii) $(2, -\frac{3}{5})$ and radius $\sqrt{2}$

Solution

$$(x - 2)^2 + (y + \frac{3}{5})^2 = (\sqrt{2})^2$$

$$x^2 + y^2 - 4x + \frac{6y}{5} - \frac{59}{25} = 0$$

$$25x^2 + 25y^2 - 100x + 30y = 59$$

Note the three above equation of the circle show that

- The coefficient of x^2 and y^2 are always equal
- There is no term in xy
- The equation of a circle is of second degree equation in x and y .

The method of completing square can enable one to deduce the centre and the radius of the circle given its equation

(b) Find the centre and the radius of the following circles:

(i) $x^2 + y^2 - 4x + 6y + 1 = 0$

solution

$$(x - 2)^2 + (y + 3)^2 = -1 + 4 + 9$$

$$(x - 2)^2 + (y + 3)^2 = 12$$

\therefore the centre is at $(2, -3)$ and the radius $= \sqrt{12} = 4\sqrt{3}$ units

(ii) $3x^2 + 3y^2 + 6x - 2y - 9 = 0$

Solution

$$x^2 + y^2 + 2x - \frac{2}{3}y - 3 = 0$$

$$(x + 1)^2 + (y - \frac{1}{3})^2 = 3 + 1 + \frac{1}{9} = \frac{37}{9}$$

\therefore the centre is at $(-1, \frac{1}{3})$ and the radius

$$= \sqrt{\frac{37}{9}} = 2.028 \text{ units}$$

In general given the circle

$$x^2 + y^2 + 2gx + 2fy + c = 0$$

$$(x + g)^2 + (y + f)^2 = -c + g^2 + f^2$$

∴ the centre is at $(-g, -f)$ and the radius

$$= \sqrt{(-c + g^2 + f^2)} \text{ units}$$

II. Given the polar equation

Suppose the equation of the circle in polar for is $r = a \cos \theta$, required is to find its equation in Cartesian form

From the polar coordinates, we have

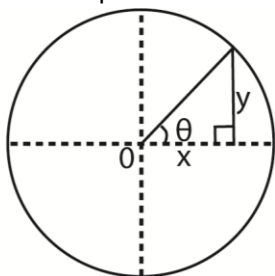

From the figure above

$$x^2 + y^2 = r^2 \dots\dots\dots (i)$$

$$x = r \cos \theta$$

$$y = r \sin \theta$$

$$\text{But } r = a \cos \theta$$

$$\Rightarrow r = a \left(\frac{x}{r} \right)$$

$$r^2 = ax$$

Substituting for r^2 into eqn. (i)

$$x^2 + y^2 = ax$$

$$x^2 + y^2 - ax = 0$$

Example 2

Find in Cartesian form the equation of a circle given

(i) $r = 2 \cos \theta$

Solution

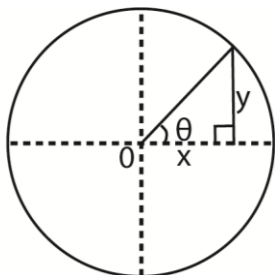

$$x^2 + y^2 = r^2 \dots\dots\dots (i)$$

$$x = r \cos \theta$$

$$y = r \sin \theta$$

$$\text{But } r = 2 \cos \theta$$

$$\Rightarrow r = 2 \left(\frac{x}{r} \right)$$

$$r^2 = 2x$$

Substituting for r^2 into eqn. (i)

$$x^2 + y^2 = 2x$$

$$x^2 + y^2 - 2x = 0$$

(ii) $r = 3 \cos \theta$

Solution

$$x^2 + y^2 = r^2 \dots\dots\dots (i)$$

$$x = r \cos \theta$$

$$y = r \sin \theta$$

$$\text{But } r = 3 \cos \theta$$

$$\Rightarrow r = 3 \left(\frac{x}{r} \right)$$

$$r^2 = 3x$$

Substituting for r^2 into eqn. (i)

$$x^2 + y^2 = 3x$$

$$x^2 + y^2 - 3x = 0$$

III. Given three non-collinear points on the circumference of the circle

(a circle circumscribing a triangle)

Method I

The general equation of the circle

$x^2 + y^2 + 2gx + 2fy + c = 0$ has three unknown: $g, f,$ and $c.$

Substituting the three points given in this equation will give us three equations in three unknowns which are solved simultaneous

Method II

The perpendicular bisectors of two or more chords pass through the centre of the circle.

Example 3

(a) Find the equation of the circle passing through the points

(i) $A(1, 1), B(2, 0)$ and $C(3, 1)$

Method 1

The general equation is

$$x^2 + y^2 + 2gx + 2fy + c = 0$$

At A(1,1): $1 + 1 + 2g + 2f + c = 0$

i.e. $2g + 2f + c = -2$ (i)

At B(2, 0): $4 + 4g + c = 0$

i.e. $4g + c = -4$ (ii)

At C(3, 1): $9 + 1 + 6g + 2f + c = 0$

i.e. $6g + 2f + c = -10$ (iii)

(i) – (iii) : $-4g = 8; g = -2$

Substituting for g in eqn. (ii)

$$-8 + c = -4; c = 4$$

Substituting for g and c into eqn. (i)

$$-4 + 2f + 4 = -2; f = -1$$

By substitution, the equation of the circle is

$$x^2 + y^2 - 4x - 2y + 4 = 0$$

Method 2

Let L and M be the perpendicular bisector of chords AB and BC

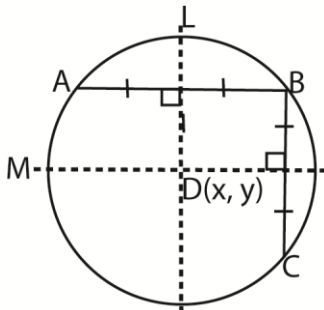

Equation of L

$$(x - 1)^2 + (y - 1)^2 = (x - 2)^2 + (y - 0)^2$$

$$2x - 2y - 2 = 0 \text{ i.e. } x - y = 1 \text{ (i)}$$

Equation of M:

$$(x - 2)^2 + (y - 0)^2 = (x - 3)^2 + (y - 1)^2$$

$$2x + 2y = 6 \text{ i.e. } x + y = 3 \text{(ii)}$$

Eqn. (i) + Eqn. (ii): $2x = 4 \Rightarrow x = 2$

Substituting for into eqn. (i), $y = 1$

∴ The centre of the circle is at D(2,1) with radius AD(or BD or CD)

Let point P(x, y) lie on the circle.

Considering AD as the centre,

$$\text{Radius, } r = \sqrt{(2 - 1)^2 + (1 - 1)^2} = 1$$

The equation of the circle is

$$(x - 2)^2 + (y - 1)^2 = (2 - 1)^2 + (1 - 1)^2$$

$$x^2 - 4x + 4 + y^2 + 2y + 1 = 1$$

$$x^2 + y^2 - 4x - 2y + 4 = 0$$

(ii) P(-2, 2), Q(2, 4) and R(5, -5)

Method 1

The general equation is

$$x^2 + y^2 + 2gx + 2fy + c = 0$$

At P(-2, 2): $4 + 4 - 4g + 4f + c = 0$

i.e. $4g - 4f + c = 8$ (i)

At Q(4, 4): $4 + 16 + 4g + 8f + c = 0$

i.e. $4g + 8f + c = -20$ (ii)

At R(5, -5): $25 + 25 + 10g - 10f + c = 0$

i.e. $10g - 10f + c = -50$ (iii)

(i) + (iii) : $8g + 4f = -12$

$2g + f = -3$ (iv)

Eqn. (ii) – eqn. (iii)

$$-6g + 18f = 30$$

$-g + 3f = 5$ (v)

2eqn. (iv) + eqn. (v)

$$7f = 7, f = 1$$

Substitution for f into eqn. (iv)

$$g = -2$$

Substitution for g and c into eqn. (i)

$$c = -20$$

By substitution, the equation of the circle is

$$x^2 + y^2 - 4x + 2y - 20 = 0$$

Method 2

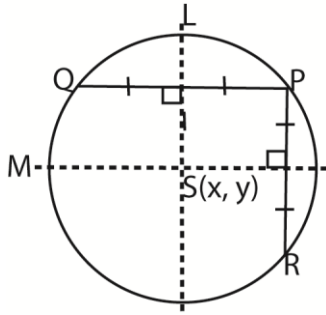

Equation of the perpendicular bisector, M of chord PQ.

Equation of M

$$(x + 2)^2 + (y - 2)^2 = (x - 2)^2 + (y - 4)^2$$

$$2x + y = 3 \dots\dots\dots (i)$$

Equation of L:

$$(x + 2)^2 + (y - 2)^2 = (x - 5)^2 + (y + 5)^2$$

$$x - y = 3 \dots\dots\dots (ii)$$

$$\text{Eqn. (i) + Eqn. (ii): } 3x = 6; x = 2$$

Substituting for x into eqn. (i): $y = -1$

\therefore the centre is at $S(2, -1)$ with radius

$$SP = \sqrt{(2 + 2)^2 + (-1 - 2)^2}$$

The equation is

$$(x - 2)^2 + (y + 1)^2 = (2 + 2)^2 + (-1 - 2)^2$$

$$x^2 + y^2 - 4x + 2y - 20 = 0$$

- (b) Find the centre and radius of a circle circumscribing triangle ABC with vertices $A(3, -2)$, $B(1, 5)$ and $C(-1, -1)$

The general equation is

$$x^2 + y^2 + 2gx + 2fy + c = 0$$

$$\text{At } A(3, -2): 9 + 4 + 6g - 4f + c = 0$$

$$\text{i.e. } 6g - 4f + c = -13 \dots\dots\dots (i)$$

$$\text{At } B(1, 5): 1 + 25 + 2g + 10f + c = 0$$

$$\text{i.e. } 2g + 10f + c = -26 \dots\dots\dots (ii)$$

$$\text{At } C(-1, -1): 1 - 2g - 2f + c = 0$$

$$\text{i.e. } -2g - 2f + c = -2 \dots\dots\dots (iii)$$

Solving equation (i), (ii) and (iii)

simultaneously, we obtain

$$g = \frac{-19}{26}, f = \frac{-37}{26}, c = \frac{-108}{13}$$

The equation of the circle

$$x^2 + y^2 - \frac{19}{13}x - \frac{37}{13}y - \frac{108}{13} = 0$$

$$\left(x - \frac{19}{26}\right)^2 + \left(y - \frac{37}{26}\right)^2 = \frac{108}{13} + \left(\frac{19}{26}\right)^2 + \left(\frac{37}{26}\right)^2$$

\therefore The centre is $\left(\frac{19}{26}, \frac{37}{26}\right)$ and

$$r = \sqrt{\frac{108}{13} + \left(\frac{19}{26}\right)^2 + \left(\frac{37}{26}\right)^2}$$

IV. Given the end points of the diameter of a circle.

Method 1

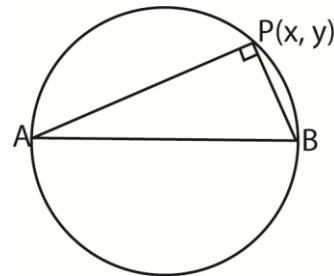

Let $P(x, y)$ be a general point on the circumference.

Since AP is perpendicular to BP (Angle is a semicircle)

$$\Rightarrow (\text{Gradient of AP}) \times (\text{Gradient BP}) = -1$$

Method 2

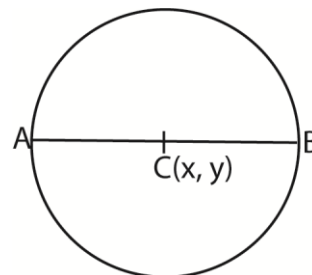

Let $C(x, y)$ be the centre of the circle.

Since AC and BC are the radii of the circle,

$$AC = CB$$

Example 4

(a) Find the equation of a circle in each case given the end points of the diameter

(i) A(1, 2) and B(-3, 4)

Solution

Either: let P(x, y) lie on the circle

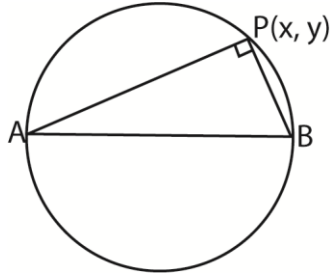

(Gradient of AP) x (Gradient BP) = -1

$$\frac{y-2}{x-1} \cdot \frac{y-4}{x+3} = -1$$

$$(y-2)(y-4) + (x-1)(x+3) = 0$$

$$x^2 + y^2 + 2x - 6y + 5 = 0$$

Or:

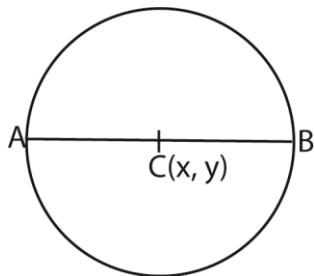

Taking C(x, y) as the centre of the circle,

$$x = \frac{1}{2}(1-3) = -1 \text{ and } y = \frac{1}{2}(2+4) = 3$$

\therefore the centre of the circle is at (-1, 3) and radius, $r = \sqrt{AC^2} = \sqrt{CB^2}$

$$= \sqrt{(-1-1)^2 + (3-2)^2} = \sqrt{5}$$

Equation of the circle:

$$(x+1)^2 + (y-3)^2 = 5$$

$$\text{i.e. } x^2 + y^2 + 2x - 6y + 5 = 0$$

(ii) P(5, -2) and Q(-1, 3)

Let R(x, y) lie on the circle

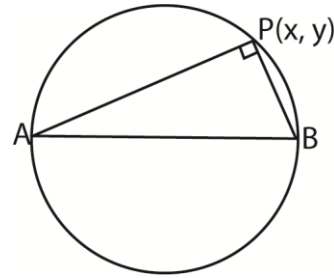

(Gradient of PR) x (Gradient RQ) = -1

$$\frac{y+2}{x-5} \cdot \frac{y-3}{x+1} = -1$$

$$(y+2)(y-3) + (x-5)(x+1) = 0$$

$$x^2 + y^2 - 4x - y - 11 = 0$$

Parametric equation of a circle

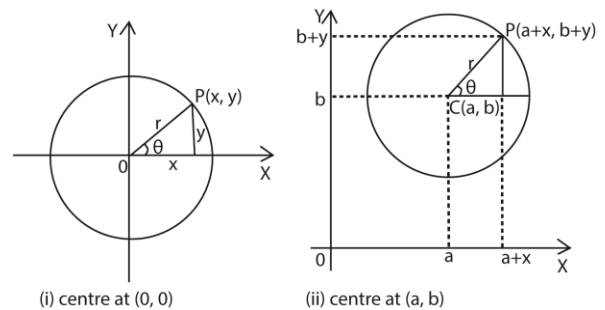

In diagram (i), any point P(x, y) has parametric coordinates, $x = r\cos\theta$ and $y = r\sin\theta$ and the circle has centre (0, 0)

In diagram (ii) any point P(a+x, b+y) has parametric coordinates, $x = a + r\cos\theta$ and $y = b + r\sin\theta$ and the circle has centre (a, b)

Example 5

Show that the parametric equations $(3+2\cos\theta, -1+\sin\theta)$ represent a circle. Determine the centre and the radius.

Solution

Given $x = 3+2\cos\theta$ and $y = -1+2\sin\theta$

$$\cos\theta = \frac{1}{2}(x - 3) \text{ and } \sin\theta = \frac{1}{2}(y + 1)$$

$$\Rightarrow \frac{1}{4}(x - 3)^2 + \frac{1}{4}(y + 1)^2 \text{ since } \cos^2\theta + \sin^2\theta = 1$$

$$(x - 3)^2 + (y + 1)^2 = 2^2$$

The locus is a circle with centre (3, -1) and radius, $r = 2$ units

Equation of the tangent and normal to the circle

The gradient of the tangent to the a circle may be got in two ways

Using gradient of radius or by differentiation of the function implicitly:

Example 6

(a) Find the equation of the tangent and normal to the circle

(i) $x^2 + y^2 + 2x - 8y + 4 = 0$ at point (2, 2)

Solution

Method 1

$$x^2 + y^2 + 2x - 8y + 4 = 0$$

$$(x + 1)^2 + (y - 4)^2 = 13$$

Centre (-1, 4)

$$\text{Gradient of the radius} = \frac{4-2}{-1-3} = \frac{-2}{3}$$

$$\text{Gradient of the tangent} = \frac{3}{2}$$

Equation of tangent

$$y - 2 = \frac{3}{2}(x - 2)$$

$$2y - 3x + 2 = 0$$

Equation of the normal

$$y - 2 = -\frac{2}{3}(x - 2)$$

$$2x + 3y = 0$$

Method 2

By differentiation of the function implicitly.

$$2x + 2y \frac{dy}{dx} + 2 - 8 \frac{dy}{dx} = 0$$

$$(2y - 8) \frac{dy}{dx} = -2x - 2$$

$$\frac{dy}{dx} = \frac{1+x}{4-y}$$

$$\text{At } (2, 2), \frac{dy}{dx} = \frac{1+2}{4-2} = \frac{3}{2}$$

Equation of tangent

$$y - 2 = \frac{3}{2}(x - 2)$$

$$2y - 3x + 2 = 0$$

Equation of the normal

$$y - 2 = -\frac{2}{3}(x - 2)$$

$$2x + 3y = 0$$

(ii) $(x - 3)^2 + (y + 2)^2 = 4$ at point (1, 0)

Solution

Either

Centre at (3, -2)

$$\text{Gradient of the radius} = \frac{-2-0}{3-1} = -1$$

Gradient of the tangent = 1

Equation of tangent

$$y - 0 = (x - 1)$$

$$y - x + 1 = 0$$

Equation of the normal

$$y - 0 = -1(x - 1)$$

$$y + x - 1 = 0$$

Or:

$$2(x - 3) + 2(y + 2) \frac{dy}{dx} = 0$$

$$\frac{dy}{dx} = \frac{3-x}{2+y}$$

$$\text{At } (1, 0); \frac{dy}{dx} = \frac{3-1}{2+0} = 1$$

Gradient of the tangent = 1

Gradient of the normal = -1

Equation of tangent

$$y - 0 = (x - 1)$$

$$y - x + 1 = 0$$

Equation of the normal

$$y - 0 = -1(x - 1)$$

$$y + x - 1 = 0$$

(b) Find the equation of the tangents to the circle $x^2 + y^2 - 8x - 6y + 9 = 0$ which are parallel to the straight line $4x - 3y + 2 = 0$

Solution

Let the tangent be of the form $y = mx + c$

From $4x - 3y + 2 = 0$

$$y = \frac{4}{3}x + c$$

$$\text{Gradient} = \frac{4}{3}$$

Equation of the tangent

$$\Rightarrow y = \frac{4}{3}x + c \text{ or } 4x - 3y + c = 0$$

Finding the radius

Method 1

Given $x^2 + y^2 - 8x - 6y + 9 = 0$ i.e.

$$(x - 4)^2 + (y - 3)^2 = 42$$

The centre is at (4, 3) and the radius is, $r = 4$

Note

The perpendicular distance, d , from the point (α, β) to the line $ax + by + c = 0$ is

$$d = \frac{|a\alpha + b\beta + c|}{\sqrt{a^2 + b^2}} \text{ units.}$$

Now the distance from the centre to the tangent is the radius $= \frac{|4(4) - 3(3) + c|}{\sqrt{4^2 + (-3)^2}} = 4$;

$$\Rightarrow c = -27 \text{ or } c = 13$$

Hence the equation of the two tangents become

$4x - 3y + 13 = 0$ or $4x - 3y - 27 = 0$

become

Method 2

From $4x - 3y + c = 0 \Rightarrow y = \frac{1}{3}(4x + c)$

Substituting y into the equation of the circle

$$x^2 + \frac{1}{9}(4x + c)^2 - 8x - 2(4x + c) + 9 = 0$$

If the line is a tangent then, $b^2 = 4ac$

$$64(c - 18) = 4(25)(c^2 - 18c + 81)$$

$$c^2 + 14c - 3159 = 0$$

$$c = 13 \text{ or } c = -27$$

Hence the equation of the two tangents become

$$4x - 3y + 13 = 0 \text{ or } 4x - 3y - 27 = 0$$

Intersection of the line and the circle



(i) $b^2 > 4ac$
(chord)

(ii) $b^2 = 4ac$
(tangent)

(iii) $b^2 < 4ac$

Given the line $y = mx + c$ and the circle

$$x^2 + y^2 = r^2$$

Substituting for y into the equation of a circle:

$$x^2 + (mx + c)^2 = r^2$$

$$(1 + m^2)x^2 + 2mcx + c^2 - r^2 = 0$$

$$4m^2c^2 = 4(1 + m^2)(c^2 - r^2) \text{ i.e. } (b^2 = 4ac)$$

$$m^2c^2 = c^2 - r^2 + m^2c^2 - m^2r^2$$

$$c^2 = r^2(1 + m^2)$$

$$c = \pm r\sqrt{(1 + m^2)}$$

The line $y = mx = \pm r\sqrt{(1 + m^2)}$ is a tangent to the circle $x^2 + y^2 = r^2$ for all values of m .

Alternatively

The circle $x^2 + y^2 = r^2$ has a centre (0, 0) and radius, r .

The distance, d from O to the line $y = mx + c$ must be the radius

Writing $y = mx + c$ as $mx - y + c = 0$

$$\text{The distance, } r = \left| \frac{m(0) - 0 + c}{\sqrt{(m^2 + (-1)^2)}} \right|$$

i.e. $c = \pm r\sqrt{(1 + m^2)}$, implying, the equation of the tangent is

$$y = mx = \pm r\sqrt{(1 + m^2)}$$

Example 7

(a) Find the value of the constant k so that the line $4x + 3y + k = 0$ is a tangent to the circle $x^2 + y^2 = 36$

Solution

Either $4x + 3y + k = 0$

$$m = \frac{dy}{dx} = -\frac{4}{3}$$

The tangent is $y = mx \pm 6\sqrt{(1 + m^2)}$

Substituting form into the equation of the

$$\text{line: } y = -\frac{4}{3}x \pm 6\sqrt{\left(1 + \frac{16}{9}\right)}$$

$$y = -\frac{4}{3}x \pm 10$$

$$3y + 4x \pm 30$$

Hence $k = \pm 30$

Or:

Given $x^2 + y^2 = 36$

Centre (0, 0) and radius $r = 6$

The distance from O to the line is 6

$$6 = \left| \frac{4(0) - 3(0) + k}{\sqrt{(4^2 + 3^2)}} \right|$$

Hence $k = \pm 30$

- (b) Show that the line $2x - 3y + 26 = 0$ is a tangent to the circle $x^2 + y^2 - 4x + 6y - 104 = 0$ and find the coordinates of the point of contact.

Solution

Method 1

$$\text{From } 2x - 3y + 26 = 0 \Rightarrow x = \frac{1}{2}(3y - 26)$$

Substituting for x into the equation of the circle;

$$\frac{1}{4}(3y - 26)^2 + y^2 - 4 \cdot \frac{1}{2}(3y - 26) + 6y - 104 = 0$$

$$13y^2 - 156y + 468 = 0 \dots\dots\dots(i)$$

For equal roots: $156^2 = 4 \times 13 \times 468$ which is true, hence a tangent.

Solving eqn. (i)

$$y = \frac{156}{2 \times 13} = 6 \text{ and } x = \frac{1}{2}(3 \times 6 - 26) = -4$$

Thus, the coordinates of the point of contact are (-4, 6)

Method 2

If the line is a tangent, then its perpendicular distance from the centre of the circle must be the radius

$$x^2 + y^2 - 4x + 6y - 104 = 0$$

$$\text{i.e. } (x - 2)^2 + (y + 3)^2 = 117$$

the centre is (2, -3) and radius $r = 3\sqrt{13}$

$$\text{Now, } \left| \frac{2(2) - 3(-3) + 26}{\sqrt{(2^2 + (-3)^2)}} \right| = \frac{39}{\sqrt{13}} = \frac{39\sqrt{13}}{13} =$$

$$3\sqrt{13}$$

Since the distance from the centre to the line is the radius, then the line is a tangent.

The length of a tangent from a given point to a circle

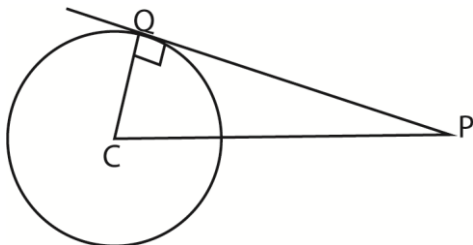

Since the radius is perpendicular to the tangent,

$$QC^2 + PQ^2 = PC^2 \text{ i.e. } PQ = \sqrt{PC^2 - QC^2}$$

Example 8

- (a) Find the value of a if the length of the tangent from the point (1, 1) to the circle $x^2 + y^2 - 4x - 6y + 3a = 0$ is 2 units

Solution

Equation of the circle

$$x^2 + y^2 - 4x - 6y + 3a = 0 \text{ i.e.}$$

$$(x - 2)^2 + (y - 3)^2 = 13 - 3a$$

Centre is (2, 3) and $r^2 = 13 - 3a$.

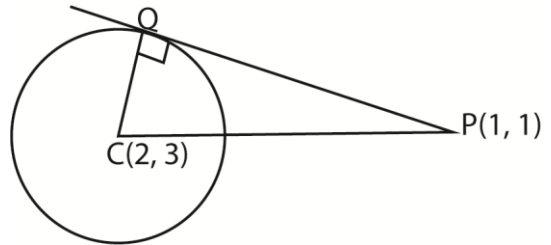

$$PQ = \sqrt{PC^2 - QC^2}$$

$$PC^2 = (2 - 1)^2 + (3 - 1)^2 = 5$$

$$QC^2 = r^2 = 13 - 3a$$

$$\therefore PQ^2 = 5 - (13 - 3a) = 2^2 = 4$$

$$3a = -5 + 13 + 4 = 12$$

$$a = 4$$

- (b) Find the equation of the tangent from the point (2, 11) to the circle $x^2 + y^2 = 25$

Solution

Method 1

Let the equation of the tangents be

$$y = mx + c \text{ which passes through } (2, 11)$$

$$\Rightarrow 11 = 3m + c \text{ i.e. } c = 11 - 2m$$

The equation of the tangent is

$$mx - y + 11 - 2m = 0$$

As it is a tangent to the circle

$$(x - 0)^2 + (y - 0)^2 = 5^2$$

$$\Rightarrow 5 = \frac{|m(0) + 11 - 2m|}{\sqrt{(m^2 + (-1)^2)}}$$

$$11 - 2m = 5\sqrt{1 + m^2}$$

$$121 - 44m + 4m^2 = 25 + 25m^2$$

$$21m^2 + 72m - 96 = 0$$

$$m = \frac{4}{3} \text{ or } m = \frac{-24}{7}$$

When $m = \frac{4}{3}$, the equation of the tangent is

$$\frac{4}{3}x - y + 11 - 2\left(\frac{4}{3}\right) = 0$$

$$4x - 3y + 25 = 0$$

When $m = \frac{-24}{7}$, the equation of the tangent

is

$$\frac{-24}{7}x - y - 2\left(\frac{-24}{7}\right) = 0$$

$$4x - 3y - 125 = 0$$

Method 2

The circle: $(x - 0)^2 + (y - 0)^2 = 5^2$

i.e. centre C(0,0) and radius r = 5

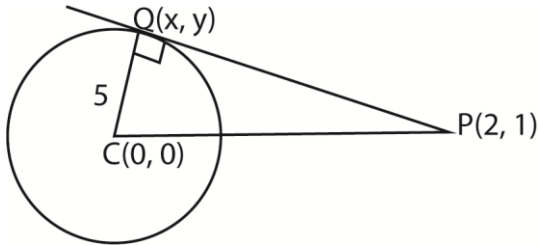

$$PQ^2 + 5^2 = CP^2$$

$$PQ^2 = (2 - 0)^2 + (11 - 0)^2 - 52 = 100$$

$$PQ = 10 \text{ units}$$

$$\text{Thus } CQ^2 = x^2 + y^2 = 5^2$$

$$x^2 + y^2 = 5^2 \dots\dots\dots(i)$$

$$\text{and } PQ^2 = (x-2)^2 + (y-11)^2 = 100$$

$$x^2 + y^2 - 4x - 22y = -25 \dots\dots\dots(ii)$$

$$\text{Eqn. (i) - eqn. (ii)}$$

$$4x + 22y = 50$$

$$y = \frac{1}{11}(25 - 2x)$$

Substituting for y into eqn. (i)

$$x^2 + \frac{1}{121}(25 - 2x)^2 = 25$$

$$125x^2 - 100x - 2400 = 0$$

$$5x^2 - 4x - 96 = 0$$

$$(5x - 24)(x + 4) = 0$$

$$x = -4 \text{ or } x = \frac{24}{5}$$

When $x = -4$; $y = \frac{1}{11}(25 - 2(-4)) = 3$ and

when $x = \frac{24}{5}$; $y = \frac{1}{11}\left(25 - 2\left(\frac{24}{5}\right)\right) = \frac{7}{5}$

The possible coordinates of Q(x, y) are (-4, 3) and $\left(\frac{24}{5}, \frac{7}{5}\right)$

Taking P(2, 1) and Q(-4, 3)

$$\text{Equation of PQ: } \frac{y-3}{x+4} = \frac{3-1}{-4-2}$$

$$\frac{y-3}{x+4} = \frac{4}{3}$$

$$4x - 3y + 25 = 0$$

Taking P(2, 11) and Q $\left(\frac{24}{5}, \frac{7}{5}\right)$

$$\text{Equation of PQ: } \frac{y-11}{x-2} = \frac{11-\frac{7}{5}}{2-\frac{24}{5}}$$

$$\frac{y-11}{x-2} = -\frac{24}{7}$$

$$24x + 7y - 125 = 0$$

The equations of the tangent from the point (1, 1) to the circle $x^2 + y^2 = 25$ are

$$4x - 3y + 25 = 0 \text{ and } 24x + 7y - 125 = 0$$

- (c) Find the length of the tangent from the origin to the circle $x^2 + y^2 - 10x + 2y + 13 = 0$.

Solution

$$x^2 + y^2 - 10x + 2y + 13 = 0$$

$$(x - 5)^2 + (y + 1)^2 = -13 + 15 + 1$$

$$(x - 5)^2 + (y + 1)^2 = 13$$

Centre, C(5, -1) and radius, $r = \sqrt{13}$

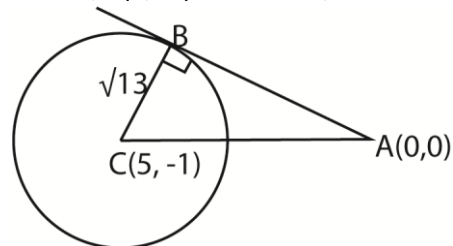

$$AB^2 = AC^2 - BC^2$$

$$AB^2 = (5 - 0)^2 + (-1 - 0)^2 - 13 = 13$$

$$AB = \sqrt{13}$$

Intersection of two circles

Two circles may intersect at two distinct points or merely just touch each other at particular point.

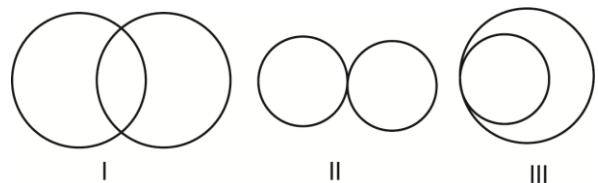

- I. Shows intersection of two circles at two distinct points.
- II. Shows touching of two circles externally
- III. Shows touching of two circles internally

When two circles intersect at two distinct points, they do so on a common chord

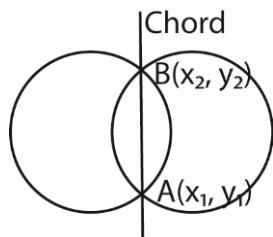

If circles touch each other, they may do so either internally or externally

External touching

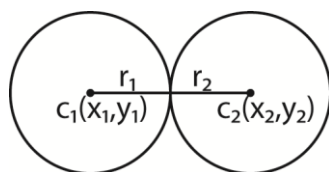

We now have $C_1C_2 = r_1 + r_2$

Where $r_1 + r_2 = \sqrt{(x_1 - x_2)^2 + (y_1 - y_2)^2}$

Internal touching

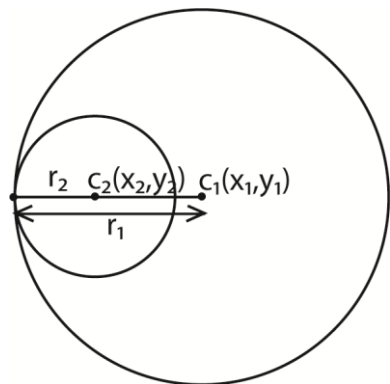

We now have $C_1C_2 = r_1 - r_2$

Where $r_1 - r_2 = \sqrt{(x_1 - x_2)^2 + (y_1 - y_2)^2}$

Concentric circles have common centre but different radii.

Example 9

- (a) Show that the circles $x^2 + y^2 - 2x - 6y + 1 = 0$ and $x^2 + y^2 - 8x - 8y + 31 = 0$ intersect in two

distinct points and hence find the length of the common chord.

Solution

$$\text{Let } x^2 + y^2 - 2x - 6y + 1 = 0 \dots\dots\dots(i)$$

$$\text{and } x^2 + y^2 - 8x - 8y + 31 = 0 \dots\dots\dots(ii)$$

$$\text{Eqn. (i) - eqn. (ii)}$$

$$6x + 2y - 30 = 0$$

$$y = 3(5 - x)$$

This is the equation of the common chord.

Substituting y into eqn. (i)

$$x^2 + 9(5 - x)^2 - 2x - 18(5 - x) + 1 = 0$$

$$10x^2 - 74x + 136 = 0$$

$$5x^2 - 37x + 68 = 0$$

$$(5x - 17)(x - 4) = 0$$

$$x = 4 \text{ or } x = \frac{17}{5}$$

$$\text{When } x = 4, y = 3(5 - 4) = 3 \text{ and}$$

$$\text{when } x = \frac{17}{5}, y = 3\left(5 - \frac{17}{5}\right) = \frac{24}{5}$$

The circles intersect in two distinct points

$$(4, 3) \text{ and } \left(\frac{17}{5}, \frac{24}{5}\right)$$

The length of the chord is the distance d between these points

$$= \sqrt{\left(4 - \frac{17}{5}\right)^2 + \left(3 - \frac{24}{5}\right)^2} = \frac{3\sqrt{10}}{5}$$

- (b) Show that the circles $x^2 + y^2 - 4x + 2y - 8 = 0$ and $x^2 + y^2 + 6x - 13y + 22 = 0$ touch each other.

Solution

Method 1

$$\text{Let } x^2 + y^2 - 4x + 2y - 8 = 0 \dots\dots\dots(i)$$

$$\text{and } x^2 + y^2 + 6x - 13y + 22 = 0 \dots\dots\dots(ii)$$

$$\text{Eqn. (ii) - eqn. (i)}$$

$$10x - 15y + 30 = 0$$

$$y = \frac{2}{3}(x + 3)$$

Substituting for y into eqn. (i)

$$x^2 + \frac{4}{9}(x + 3)^2 - 4x + \frac{4}{3}(x + 3) - 8 = 0$$

$$x = 0$$

$$\text{when } x = 0, y = \frac{2}{3}(0 + 3) = 2$$

∴ The circles intersect at only one point

$(0, 2)$, hence touching each other.

Method 2

If the circles touch, the distance between their centres C_1 and C_2 is the sum of their radii r_1 and r_2 , i.e. $r_1 + r_2 = C_1C_2$.

Also $(r_1 + r_2)^2 = (C_1C_2)^2$

For $x^2 + y^2 - 4x + 2y - 8 = 0$

$(x - 2)^2 + (y + 1)^2 = 8 + 4 + 1$

$(x - 2)^2 + (y + 1)^2 = 13$

$\therefore C_1(2, -1)$ and $r_1 = \sqrt{13}$

For $x^2 + y^2 + 6x - 13y + 22 = 0$

$(x + 3)^2 + (y - 6.5)^2 = -22 + 9 + 42.25$

$(x + 3)^2 + (y - 6.5)^2 = 29.25$

$\therefore C_2(-3, 6.5)$ and $r_2 = \sqrt{29.25}$

$C_1C_2 =$

$\sqrt{(2 - (-3))^2 + (-1 - 6.5)^2} = 9.014$

$r_1 + r_2 = \sqrt{13} + \sqrt{29.25} = 9.014$

\therefore the circles touch each other externally since $C_1C_2 = r_1 + r_2$

(c) Show that the circles

$x^2 + y^2 - 6x - 2y + 1 = 0$ and

$x^2 + y^2 + 2x - 8y + 13 = 0$ touch each other

and find the equation of the tangent at the point of contact.

Solution

For $x^2 + y^2 - 6x - 2y + 1 = 0$

$x^2 + y^2 - 6x - 2y = -1$

$(x - 3)^2 + (y - 1)^2 = -1 + 9 + 1$

$(x - 3)^2 + (y - 1)^2 = 9$

$\therefore C_1(3, 1)$ and radius $= \sqrt{9} = 3$

For $x^2 + y^2 + 2x - 8y + 13 = 0$

$x^2 + y^2 + 2x - 8y = -13$

$(x + 1)^2 + (y - 4)^2 = -13 + 1 + 16$

$(x + 1)^2 + (y - 4)^2 = 4$

$C_1C_2 = \sqrt{(3 - (-1))^2 + (1 - 4)^2} = 5$

$r_1 + r_2 = 3 + 2 = 5$

\therefore the circles touch each other externally since $C_1C_2 = r_1 + r_2$

Finding the equation of the tangent;

Let $x^2 + y^2 - 6x - 2y + 1 = 0$ (i)

And $x^2 + y^2 + 2x - 8y + 13 = 0$(ii)

Eqn. (i) – eqn. (ii)

$8x - 6y + 12 = 0$

$3y = 4x + 6$

$y = \frac{4}{3}x + 2$

(d) A circle A passes through the point $(t+2, 3t)$ and has the centre at $(t, 3t)$. Circle B has radius 2 and its centre at $(t+2, 3t)$.

(i) Determine the equations of the circles A and B in terms of t .

Solution

Radius of circle A:

$r^2 = (t + 2 - t)^2 + (3t - 3t)^2 = 2^2$

Equation of circle A

$(x - t)^2 + (y - 3t)^2 = 2^2$

$x^2 + y^2 - 2tx - 6ty + 10t^2 - 4 = 0$

Equation of B

$(x - (t+2))^2 + (y - 3t)^2 = 2^2$

$x^2 + y^2 - 2(t+2)x - 6ty + 10t^2 - 4t = 0$

(ii) If $t = 1$, show that circles A and B intersect at $(2, 3 \pm \sqrt{3})$

Solution

When $t = 1$

Equation of A

$x^2 + y^2 - 2x - 6y + 6 = 0$ (i)

Equation of B

$x^2 + y^2 - 6x - 6y + 14 = 0$ (ii)

Eqn. (i) – eqn. (ii)

$4x - 8 = 0 \Rightarrow x = 2$

Substituting x into eqn. (i)

$4 + y^2 - 4 - 6y$

$y^2 - 6y + 6 = 0$

$y = \frac{6 \pm \sqrt{36 - 4(1)(6)}}{2(1)}$

$= \frac{6 \pm \sqrt{9 - 6}}{1}$

$= 3 \pm \sqrt{3}$

Hence the point of intersection is $(2, 3 \pm \sqrt{3})$

(iii) Show that the area of the region of intersection of the two circles A and B

is $8\left(\frac{\pi}{3} - \frac{\sqrt{3}}{4}\right)$.

Solution

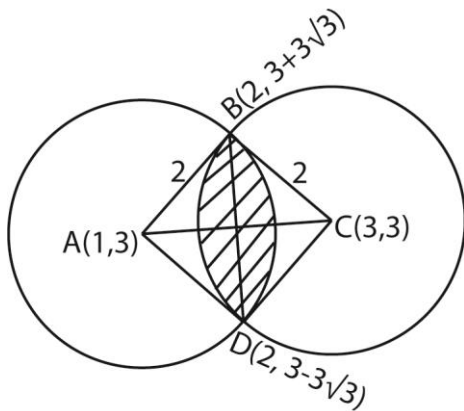

$$BD^2 = (2 - 2)^2 + (3 + \sqrt{3} - (3 - \sqrt{3}))^2$$

$$= (2\sqrt{3})^2$$

$$BD = 2\sqrt{3}$$

In triangle ABD: $\cos B = \cos D = \frac{\sqrt{3}}{2}$

Angle B = angle D = 30°

Angle A = 120° (angle sum of triangle)

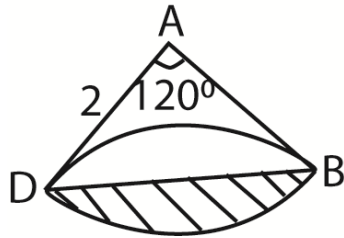

$$\text{Total area of the figure} = \frac{120}{360} \pi x 2x2 = \frac{4\pi}{3}$$

$$\text{Area of triangle ABD} = \frac{1}{2} x 2x2 \sin 120$$

$$= 2x \frac{\sqrt{3}}{2} = \sqrt{3}$$

$$\text{Area of the shaded region} = \frac{4\pi}{3} - \sqrt{3}$$

Area of the region of intersection

$$= 2 \left(\frac{4\pi}{3} - \sqrt{3} \right)$$

$$= 8 \left(\frac{\pi}{3} - \frac{\sqrt{3}}{4} \right)$$

Orthogonal circles

Two circles cut orthogonally if the tangent at the point of intersection is at right angle.

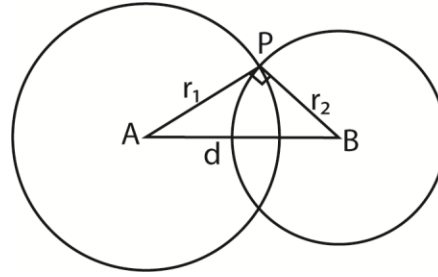

From the circles above

$$PA^2 + PB^2 = AB^2$$

$$r_1^2 + r_2^2 = d^2 \text{ (condition for orthogonality)}$$

Alternatively

Given two circles $x^2 + y^2 + 2g_1x + 2f_1y + c_1 = 0$ and $x^2 + y^2 + 2g_2x + 2f_2y + c_2 = 0$

By completing squares, we have

$$(x+g_1)^2 + (y+f_1)^2 = -c_1 + g_1^2 + f_1^2$$

Centre, $C_1(-g_1, -f_1)$ radius, $r_1^2 = -c_1 + g_1^2 + f_1^2$

Similarly, $C_2(-g_2, -f_2)$ radius, $r_2^2 = -c_2 + g_2^2 + f_2^2$

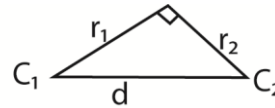

$$(C_1C_2)^2 = r_1^2 + r_2^2$$

$$(g_2 - g_1)^2 + (f_2 - f_1)^2 = -c_1 + g_1^2 + f_1^2 - c_2 + g_2^2 + f_2^2$$

$$g_2^2 - 2g_2g_1 + g_1^2 + f_2^2 - 2f_2f_1 + f_1^2$$

$$= -c_1 + g_1^2 + f_1^2 - c_2 + g_2^2 + f_2^2$$

$2g_2g_1 + 2f_2f_1 = c_1 + c_2$ (condition for orthogonality)

Example 10

(a) Show that the circle $x^2 + y^2 + 10x - 4y - 3 = 0$ and $x^2 + y^2 - 2x - 6y + 5 = 0$ are orthogonal.

Solution

Method 1

Completing squares

$$\text{For } x^2 + y^2 + 10x - 4y - 3 = 0$$

$$(x + 5)^2 + (y - 2)^2 = 3 + 25 + 4 = 32$$

$C_1 = (-5, 2)$ and $r_1^2 = 32$
 For $x^2 + y^2 - 2x - 6y + 5 = 0$
 $(x - 1)^2 + (y - 3)^2 = -5 + 1 + 9 = 5$
 $C_2 = (1, 3)$ and $r_1^2 = 5$
 Let d = distance between the centres of the two circles.
 $d^2 = (1+5)^2 + (3 - 1)^2 = 37$
 and $r_1^2 + r_2^2 = 32 + 5 = 37$ hence orthogonal.

Method 2

Using $2g_2g_1 + 2f_2f_1 = c_1 + c_2$
 $2(-5)(1) + 2(2)(3) = -3 + 5$
 $-10 + 12 = 2$
 $2 = 2$ (hence orthogonal)

- (b) Find the equation of the circle which passes through points (1, 1), (1, -1) and is orthogonal to $x^2 + y^2 = 4$.

Solution

The general equation is
 $x^2 + y^2 + 2gx + 2fy + c = 0$ (i)
 Centre $C(-g, -f)$ and $r^2 = g^2 + f^2 - c$
 For $x^2 + y^2 = 4$.
 $C(0, 0)$ and $r^2 = 4$
 But $(C_1C_2)^2 = r_1^2 + r_2^2$
 $g^2 + f^2 - c = g^2 + f^2 - c + 4$
 Through (1, 1) => $1 + 1 + 2g + 2f + 4 = 0$
 $2g + 2f = -6$ (ii)
 Through (1, -1) => $1 + 1 + 2g - 2f + 4 = 0$
 $2g - 2f = -6$ (iii)
 Eqn. (ii) + eqn. (iii)
 $4g = -12; g = -2$
 Substituting for g in equation (ii)
 $2(-3) + 2f = -6; f = 0$
 Substituting for c, g and f into eqn. (i)
 The equation of the circle
 $x^2 + y^2 - 6x + 4 = 0$

- (c) Find the equation of the circle which passes through the origin and cuts the two circles $x^2 + y^2 - 6x + 8 = 0$ and $x^2 + y^2 - 2x - 2y - 7 = 0$ orthogonally

Solution

The general equation is
 $x^2 + y^2 + 2gx + 2fy + c = 0$

when it passes through the origin $c = 0$,
 hence it becomes

$x^2 + y^2 + 2gx + 2fy = 0$ (i)

Centre $C(-g, -f)$ and $r^2 = g^2 + f^2$

Given $x^2 + y^2 - 6x + 8 = 0$

$(x - 3)^2 + (y - 0)^2 = -8 + 9 = 1$

Centre $C_1(3, 0)$ and $r_1^2 = 1$

If they cut orthogonally

$(C_1C_2)^2 = r_1^2 + r_2^2$

$(3 + g)^2 + (0 + f)^2 = g^2 + f^2 + 1$

$9 + 6g + g^2 + f^2 = g^2 + f^2 + 1$

$6g = -8$

$g = -\frac{4}{3}$

Similarly, given $x^2 + y^2 - 2x - 2y - 7 = 0$

$(x - 1)^2 + (y - 1)^2 = 7 + 1 + 1 = 9$

Centre $C_1(1, 1)$ and $r_1^2 = 9$

If it cuts orthogonally,

$(C_1C_2)^2 = r_1^2 + r_2^2$

$(1 + g)^2 + (1 + f)^2 = g^2 + f^2 + 9$

$1 + 2g + g^2 + 1 + 2f + f^2 = g^2 + f^2 + 9$

$2g + 2f = 7$

Substituting for g

$2\left(-\frac{4}{3}\right) + 2f = 7, f = \frac{29}{6}$

Substituting for g and f into eqn. (i), the equation of the circle is

$x^2 + y^2 + 2\left(-\frac{4}{3}\right)x + 2\left(\frac{29}{6}\right)y = 0$

$x^2 + y^2 - \frac{8}{3}x + \frac{29}{3}y = 0$

$3x^2 + 3y^2 - 8x + 29y = 0$

Example 11

1. A circle whose centre is in the first quadrant touches the x – and y – axes and the line $8x - 15y = 120$. Find the
 (a) equation of the circle (10marks)

Solution

$$\text{Radius } a = \frac{|8a - 15a - 120|}{\sqrt{8^2 + (-15)^2}}$$

$$= \frac{|-7a + 120|}{17}$$

$17a = 7a + 120$

$10a = 120$

$a = 12$

Equation of the circle
 $(x - 12)^2 + (y - 12)^2 = 12^2$
 $x^2 + y^2 - 24x - 24y + 144 = 0$

(b) point at which the circle touches the x-axis. (02marks)

$y = 0$
 $(x - 12)^2 = 0$
 $x = 12$
the point (12, 0)

Example 12

The position vectors of the vertices of a triangle are O, r and s, where O is the origin. Show that its area (A) is given by $4A^2 = |r|^2 |s|^2 - (r \cdot s)^2$. (06marks)

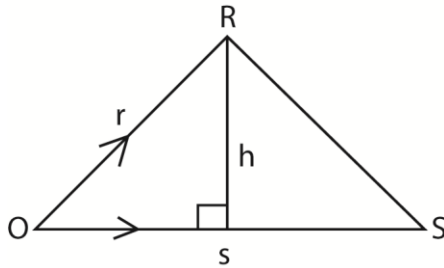

Revision Exercise 1

- A point P is such that its distance from the origin is five times its distance from the point (12, 0). Show that the locus of P is a circle and find its radius. $[(5, -6); \sqrt{61}]$
- If $P(x_1, y_1)$ is a point outside the circle, $x^2 + y^2 + 2gx + 2fy + c = 0$, show that the length of the tangent PT from P to the circle is given by $PT^2 = x_1^2 + y_1^2 + 2gx_1 + 2fy_1 + c$
Two circles have centres A(1, 3) and B(6, 8) and intersect at C(2, 6) and D, find the equation of each of the circles and that of line CD. The tangents to the circles from a point P are of equal length. Verify that lie on CD.

$$\left[\begin{array}{l} x^2 + y^2 - 10x = 0 \\ \text{and} \\ x^2 + y^2 - 11x - 7y + 30 = 0 \end{array} \right]$$

- (a) find the equation of the tangent and the normal to the circle

$$r \cdot s = |r||s| \cos O$$

$$(r \cdot s)^2 = |r|^2 |s|^2 \cos^2 O$$

$$\sin^2 O = 1 - \frac{(r \cdot s)^2}{|r|^2 |s|^2} = \frac{|r|^2 |s|^2 - (r \cdot s)^2}{|r|^2 |s|^2}$$

$$A = \frac{1}{2} |r||s| \sin O$$

$$2A = |r||s| \sin O$$

$$4A^2 = |r|^2 |s|^2 \sin^2 O$$

$$4A^2 = |r|^2 |s|^2 \cdot \frac{|r|^2 |s|^2 - (r \cdot s)^2}{|r|^2 |s|^2}$$

$$4A^2 = |r|^2 |s|^2 - (r \cdot s)^2$$

Hence, find the area of a triangle when $r = \begin{pmatrix} 2 \\ 3 \end{pmatrix}$

and $s = \begin{pmatrix} 1 \\ 4 \end{pmatrix}$ (06marks)

$$|r|^2 = 2^2 + 3^2 = 13$$

$$|s|^2 = 1^2 + 4^2 = 17$$

$$r \cdot s = \begin{pmatrix} 2 \\ 3 \end{pmatrix} \cdot \begin{pmatrix} 1 \\ 4 \end{pmatrix} = (2 \times 1) + (3 \times 4) = 14$$

$$\therefore 4A^2 = 13 \times 17 - 14^2 = 25$$

$$A = \sqrt{\frac{25}{4}} = 2.5 \text{ units}$$

$$3x^2 + 3y^2 + 6x - 4y - 15 = 0 \text{ at the point } (-2, 3)$$

$$[7y - 3x + 15 = 0, 3y + 7y + 5 = 0]$$

(b) Show that the circles

$$3x^2 + 3y^2 - 2x - 2y + 1 = 0 \text{ and}$$

$$3x^2 + 3y^2 - 6x - 4y + 9 = 0 \text{ cut}$$

orthogonally.

(c) Find the equation of the circle which passes through points (1, 1), (1, -1) and is orthogonal to $x^2 + y^2 = 4$. $[x^2 + y^2 - 6x + 4 = 0]$

- A circle A passes through the point (t+2, 3t) and has the centre at (t, 3t). Circle B has radius 2 and its centre at (t+2, 3t).

(i) Determine the equations of the circles A and B in terms of t.

$$[x^2 + y^2 - 2(t+2)x - 6ty + 10t^2 - 4t = 0]$$

- (ii) If $t = 1$, show that circles A and B intersect at $(2, 3 \pm \sqrt{3})$
- (iii) Show that the area of the region of intersection of the two circles A and B is $8\left(\frac{\pi}{3} - \frac{\sqrt{3}}{4}\right)$.
5. The equation of circle, centre O is given by $x^2 + y^2 + Ax + By + C = 0$ where A, B and C are constant. Given that $4A = 3B$, $3A = 2c$ and $C = 9$
- (a) Determine
- The coordinates of the centre of the circle $[(-3, -4)]$
 - The radius of the circle [4 units]
- (b) A tangent is drawn from the point Q(3, 2) to the circle. Find
- the coordinates of P, the point where the tangent meets the circle $[(-4.16, -0.17) \text{ or } (0.83, -5.16)]$
 - the area of the triangle QPO. [14.96]
6. find the orthocentre (point of intersection of the altitude) of the triangle with vertices A(-2, 1), B(3, -4) and C(-6, -1) $[(-2, -4)]$
7. (a) Find the equation of the circle circumscribing the triangle whose vertices are A(1, 3), B(4, -5) and C(9, -1). Find also the radius of the circle.
- $\left[x^2 + y^2 - \frac{113}{13}x + \frac{8}{13}y - \frac{41}{13} = 0; r = 4.71\right]$
- (b) If the tangent to the circle at A(1, 3) meets the x-axis at P(h, 0) and the y-axis at Q(10, k), find the values of h and k. $[h = -2, k = 2]$
8. Find the equation of a circle which passes through the points (5, 7), (1, 3) and (2, 2). $[x^2 + y^2 - 7x - 9y + 24 = 0]$
9. (a) If $x = 0$ and $y = 0$ are tangents to the circle $x^2 + y^2 + 2gx + 2fy + c = 0$; show that $c = g^2 = f^2$.
- (b) Given that the line $3x - 4y + 6 = 0$ is also tangent to the circle in (a) above; determine the equation of the circle lying in the first quadrant. $[x^2 + y^2 - 2x - 2y + 1 = 0]$
10. Form the equation of a circle that passes through points A(-1, 4), B(2, 5) and C(0, 1) $[x^2 + y^2 - 2x - 6y + 5 = 0]$
11. The line $x + y = c$ is a tangent to the circle $x^2 + y^2 - 4y + 2 = 0$. Find the coordinates of the point of contact of the tangent for each value of c. $[(1, 3)]$
12. ABCD is a square inscribed in a circle $x^2 + y^2 - 4x - 3y = 36$. Find the length of the diagonal and the area of the square. [13, 84.5]

Parabola

A parabola is a locus of a point say P which moves so that its distance from a fixed point (the focus) is always equal to its perpendicular distance from a fixed straight line (the directrix)

The general shape is as follows.

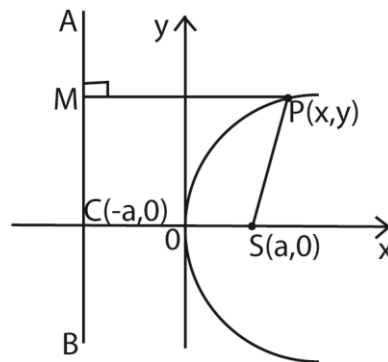

- $S(a,0)$ is the focus (fixed point)
- $P(x, y)$ is the variable point

Please find free notes, tests and marking guides of physics, chemistry, biology and mathematics from: digitalteachers.co.uk

- $x = -a$ is the equation of the directrix (fixed line or line AB).
- O is the vertex of the above parabola (line of symmetry)
- OS is the focal length
- PM is the perpendicular distance from the curve at P to the directrix.
- The focus, S lies on the x-axis and has coordinates $S(a, 0)$ where a is a constant.

Equation of a parabola

By the above definition

$$\frac{PS}{PM} = 1$$

$$PS^2 = PM^2$$

$$(x - a)^2 + y^2 = (x + a)^2$$

$$x^2 - 2ax + a^2 + y^2 = x^2 + 2ax + a^2$$

$$y^2 = 4ax$$

Length of the latus rectum of a parabola

A latus rectum is a line perpendicular to the axis of the parabola and passing through the focus $S(a, 0)$

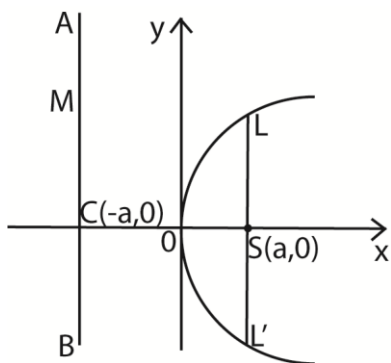

In the diagram above, LL' is the length of **latus rectum**.

Its length can be derived as follows

The x-coordinates of L is a .

The corresponding y-coordinate is obtained by substituting the value of x in the equation of the parabola $y^2 = 4ax$

$$y^2 = 4a^2 \text{ or } y = \pm 2a$$

The coordinates of L and L' are $L(a, 2a)$ and $L'(a, -2a)$

$$\text{Length } LL' = 2a + 2a = 4a$$

\therefore the length of the latus rectum is $4a$ units.

Parametric equation of a parabola

A typical point on the parabola can be represented by the equation

$x = at^2$ and $y = 2at$, where t is the parameter.

These express the coordinates of a point on the curve in terms of the parameter, t . Such a point can be referred to as ' t '.

However, other parameters may be used like p and q , hence $P(ap^2, 2ap)$ and $Q(aq^2, 2aq)$ etc. Using the above reference, these are points ' p ' and ' q ' respectively.

To show the point $P(at^2, 2at)$ lies on the parabola $y^2 = 4ax$

This is done in two ways

- When the point on the parabola is (x_1, y_1) . The tangent to the parabola at this point is established by differentiating the $y^2 = 4ax$ with respect to x .

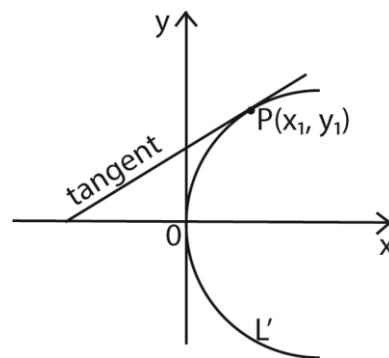

Using the equation $y^2 = 4ax$

$$2y \frac{dy}{dx} = 4a$$

$$\frac{dy}{dx} = \frac{2a}{y}$$

At the point $P(x_1, y_1)$

$$\frac{dy}{dx} = \frac{2a}{y_1}$$

$$\Rightarrow \frac{y - y_1}{x - x_1} = \frac{2a}{y_1}$$

$$yy_1 - y_1^2 = 2ax - 2ax_1$$

Since the point $P(x_1, y_1)$ lies on the parabola, we replace y_1^2 and $4ax_1$

$$\Rightarrow yy_1 - 4ax = 2ax - 2ax_1$$

$$yy_1 = 2ax + 2ax_1$$

$$yy_1 = 2a(x + x_1)$$

Finding the equation of the normal at $P(x_1, y_1)$

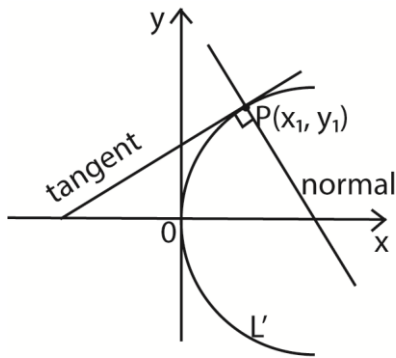

Now the gradient of the normal at $P(x_1, y_1)$

$$= -\frac{y_1}{2a}$$

$$\frac{y - y_1}{x - x_1} = -\frac{y_1}{2a}$$

$$2ay - 2ay_1 = y_1(x - x_1)$$

$$y - y_1 = \frac{y_1}{2a}(x - x_1)$$

(ii) Finding the equation of the normal given parametric equation

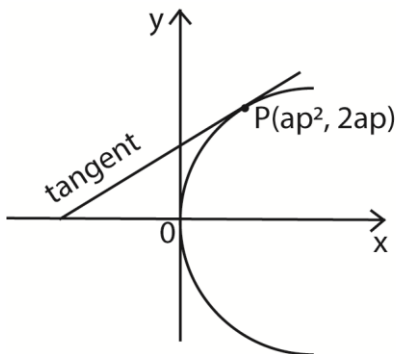

At $P(ap^2, 2ap)$, $x = ap^2$ and $y = 2ap$

$$\frac{dx}{dp} = 2ap \text{ and } \frac{dy}{dp} = 2a$$

The gradient $\frac{dy}{dx} = \frac{dy}{dp} \times \frac{dp}{dx} = \frac{2a}{2ap} = \frac{1}{p}$

Gradient of the normal = -p

The equation of the normal at $P(ap^2, 2ap)$

$$\frac{y - 2ap}{x - ap^2} = -p$$

$$y - 2ap = -p(x - ap^2)$$

$$y + px - ap(2 - p^2) = 0$$

The point where the normal meets the parabola again

The coordinates of the point where the normal meets the parabola again can be computed as follows

Let the normal at $P(ap^2, 2ap)$ meets the parabola again at $Q(aq^2, 2aq)$

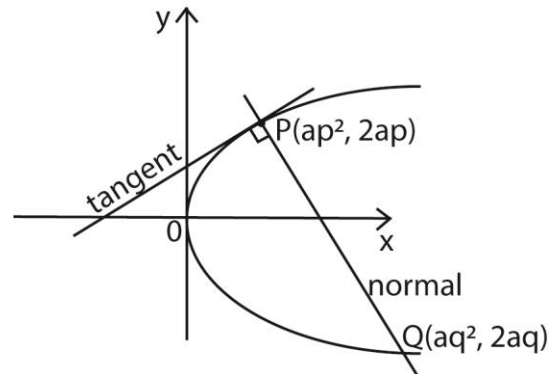

Either

The gradient of the normal, $PQ = -p$

$$\Rightarrow \frac{2ap - 2aq}{ap^2 - aq^2} = -p$$

$$\frac{2(p - q)}{(p - q)(p + q)} = -p$$

$$\frac{2}{(p + q)} = -p$$

$$q = \left(p + \frac{2}{p}\right)$$

Substituting for the parameter q in the point of $Q(aq^2, 2aq)$ the coordinates are

$$Q\left(a\left(p + \frac{2}{p}\right)^2, 2a\left(p + \frac{2}{p}\right)\right)$$

Or

At the point S of intersection of the normal and parabola:

Equation of the normal:

$$y + px = ap^2 + ap^3 \dots\dots\dots(i)$$

Equation of parabola: $y^2 = 4ax \dots\dots\dots(ii)$

From eqn. (i) $y = ap(2 - p^2) - px$

Substituting in eqn. (ii): $[ap(2 + p^2)]^2 = 4ax$
 $p^2x^2 - 2a[2+p^2(2+p^2)]x + a^2p^2(2+p^2)^2 = 0$
 Solving the above quadratic equation of gives

$$x = ap^2 \text{ or } x = a\left(p + \frac{2}{p}\right)^2$$

the 1st value is the x-coordinate of P and the second value is the required x- coordinate of Q.

Or

The equation of the normal at P is

$$y + px = ap^2 + ap^3$$

If this normal passes through Q, then the coordinates of Q satisfy the equation

Substituting for $x = aq^2$ and $y = 2aq$

$$p(aq^2) + 2aq = 2ap + ap^3$$

$$2a(q - p) = ap(p^2 - q^2)$$

$$-2a(p - q) = ap(q^2 - p^2)$$

$$-2a(p - q) = ap(q - p)(q + p)$$

$$-2 = p(q + p)$$

$$q = \left(p + \frac{2}{p}\right)$$

Substituting for the parameter q in the point of Q(aq^2 , $2aq$) the coordinates are

$$Q\left(a\left(p + \frac{2}{p}\right)^2, 2a\left(p + \frac{2}{p}\right)\right)$$

Equation of the chord

The chord of a parabola is the straight line meeting the curve at two distinct points.

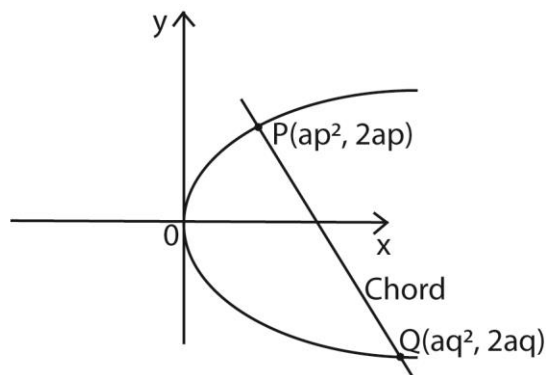

$$\text{The gradient of the chord} = \frac{2ap - 2aq}{ap^2 - aq^2} = \frac{2}{p+q}$$

The equation of the chord PQ

$$\frac{y - 2ap}{x - ap^2} = \frac{2}{p+q}$$

$$(p + q)y = 2x + 2apq$$

Deducing the equation of the tangent from the equation of the chord

For the tangent at P, visualize the chord PQ as it turns about P, i.e. $q \rightarrow p$.

i.e. Equation of the tangent at P arises when $p = q$

$$\text{From } (p + q)y = 2x + 2apq$$

$$\text{When } q = p: 2py = 2x + 2ap^2 \text{ or } py = x + ap^2$$

Similarly, the equation of the tangent at Q arises as $p \rightarrow q$; then

$$qy = x + aq^2$$

Equation of the focal chord

Focal chord is a chord passing through the focus.

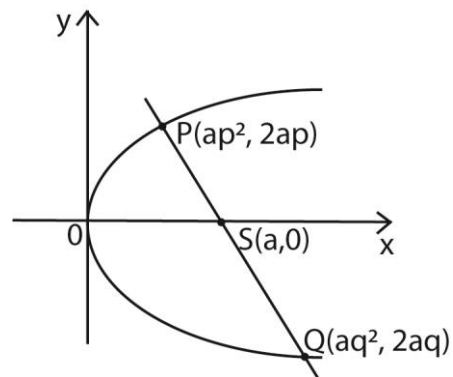

The coordinates of the focus, $S(a, 0)$ satisfy the equation of the chord as it passes through it.

$$\text{From the chord: } (p + q)y = 2x + 2apq$$

$$\text{Substituting for } x=a \text{ and } y = 0$$

$$pq + 1 = 0$$

This relationship between the parameters p and q is the condition for the chord to pass through the focus.

It can also be derived as follows

The gradient of PS = gradient of SQ

$$\frac{2ap - 0}{ap^2 - 1} = \frac{0 - 2aq}{a - aq^2}$$

$$pq + 1 = 0$$

The midpoint of the chord

Given two points P(ap², 2ap) and Q(aq², 2aq), the midpoint is $M\left(\frac{1}{2}a(p^2 + q^2), a(p + q)\right)$

The locus of the midpoint of the focal chord

Eliminating the given parameters from the given equation gives the locus of any curve.

From $x = \frac{1}{2}a(p^2 + q^2), p^2 + q^2 = \frac{2x}{a}$ (i)

And $y = a(p + q) \Rightarrow p + q = \frac{y}{a}$ (ii)

Squaring eqn. (ii); $p^2 + q^2 + 2pq = \frac{y^2}{a^2}$ (iii)

Substituting eqn. (i) into eqn. (ii)

$$\frac{2x}{a} + 2pq = \frac{y^2}{a^2}$$

Now for a focal chord, $pq = -1$

$$\frac{2x}{a} + 2(-1) = \frac{y^2}{a^2}$$

$$y^2 = 2a(x - a)$$

Intersection of two tangents

Let the tangents at P and Q intersect at R(x, y)

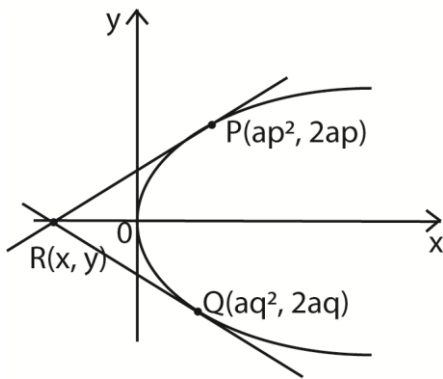

Equation of the tangent at P: $py = x + ap^2$ (i)

Equation of the tangent at Q: $qy = x + aq^2$ (ii)

Eqn. (i) – eqn. (ii)

$$(p - q)y = a(p^2 - q^2) \text{ or } y = a(p + q)$$

Substituting y into equation (i)

Please find free notes, tests and marking guides of physics, chemistry, biology and mathematics from: digitalteachers.co.uk

$$ap(p+q) = x + ap^2 \text{ i.e. } x = apq$$

$$R(x, y) = (apq, a(p+q))$$

If PQ is a focal chord, the x-coordinate of R becomes $a(-1) = -a$; $x = -a$

∴ The tangent at P and Q meets on the directrix if PQ is a focal chord.

Intersection of two normal

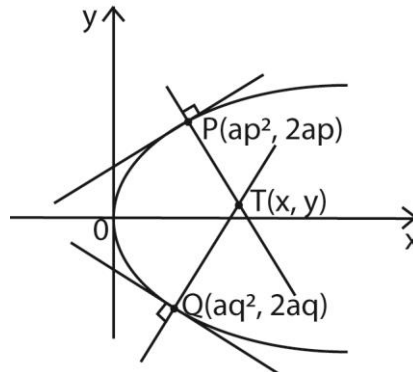

Eqn. of the normal at P: $px + y = 2ap + ap^3$ (i)

Eqn. of the normal at Q: $qx + y = 2aq + aq^3$ (ii)

eqn. (i) – eqn. (ii)

$$(p - q)x = 2a(p - q) + a(p - q)(p^2 + pq + q^2)$$

$$x = 2a + a(p^2 + pq + q^2)$$

Substituting for x into eqn. (i)

$$p[2a + a(p^2 + pq + q^2)] + y = 2ap + ap^3$$

$$y = -apq(p + q)$$

$$\therefore T(2a + a(p^2 + pq + q^2), -apq(p + q))$$

The condition that the line $y = mx + c$ is a tangent to the parabola.

At the point of tangency, the roots must be equal.

Equation of the line: $y = mx + c$ (i)

Equation of parabola: $y^2 = 4ax$ (ii)

Solving eqn. (i) and eqn. (ii) simultaneously, substitute for y into eqn. (ii)

$$(mx + c)^2 = 4ax$$

$$m^2x^2 + 2mcx + c^2 = 4ax$$

$$m^2x^2 + 2(mc - 2a)x + c^2 = 4ax$$

This line is a tangent when $b^2 = 4ac$

$$4(mc - 2a)^2 = 4m^2c^2$$

$$m^2c^2 - 4amc + 4a^2 = m^2c^2$$

$$mc = a \text{ i.e. } c = \frac{a}{m}$$

∴ The line $y = mx + c$ is a tangent to the curve

$$y = 4ax \text{ when } c = \frac{a}{m}$$

Finding the point of contact between the tangent and the parabola

$$\text{From } m^2x^2 + 2(mc - 2a)x + c^2 = 0$$

$$m^2x^2 + 2\left(m \cdot \frac{a}{m} - 2a\right)x + c^2 = 0$$

$$m^2x^2 - 2ax + c^2 = 0$$

$$x^2 - \frac{2ax}{m^2} + \frac{c^2}{m^2} = 0$$

If the roots of this equation are equal, they are given by half the sum of roots

$$\text{Now sum of roots} = \frac{2a}{m^2}$$

$$\Rightarrow x = \frac{1}{2} \cdot \frac{2a}{m^2} = \frac{a}{m^2} \text{ and } y = m \cdot \frac{a}{m^2} + \frac{a}{m} = \frac{2a}{m}$$

$$\text{Hence the point of contact is } \left(\frac{a}{m^2}, \frac{2a}{m}\right)$$

Example 13

- (a) A chord of the parabola $y^2 = 4ax$ subtends a right angle at the vertex. Show that the locus of the midpoint of the chord is $y^2 = 2a(x - 4a)$

Solution

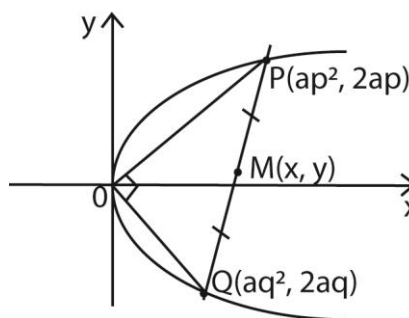

Given two points $P(ap^2, 2ap)$ and $Q(aq^2, 2aq)$ the midpoint, (x, y) of PQ is $x = \frac{1}{2}(ap^2 + aq^2) = \frac{1}{2}a(p^2 + q^2)$ and $y = \frac{1}{2}(2ap + 2aq) = \frac{1}{2}a(p + q)$

The coordinates of

$$M(x, y) = \left(\frac{1}{2}a(p^2 + q^2), \frac{1}{2}a(p + q)\right)$$

Eliminating parameters, p and q from the given equations

$$x = \frac{1}{2}a(p^2 + q^2) \Rightarrow p^2 + q^2 = \frac{2x}{a} \dots (i)$$

$$\text{and } y = \frac{1}{2}a(p + q) \Rightarrow p + q = \frac{y}{a} \dots (ii)$$

$$\text{Squaring eqn. (ii) } p^2 + q^2 + 2pq = \frac{y^2}{a^2} \dots (iii)$$

Substituting eqn. (i) into eqn. (iii)

$$\frac{2x}{a} + 2pq = \frac{y^2}{a^2} \dots (iv)$$

Since OP and OQ are perpendicular, the gradient of $OP \times$ gradient of $OQ = -1$

$$\frac{2ap-0}{ap^2-0} \cdot \frac{2aq-0}{2aq-0} = -1$$

$$\frac{2}{p} \cdot \frac{2}{q} = -1$$

$$pq = -4$$

Substituting for pq into eqn. (iv)

$$\frac{2x}{a} - 4 = \frac{y^2}{a^2}$$

$$y^2 = 2ax - 8a^2$$

$$y^2 = 2a(x - 4a); \text{ As required}$$

- (b) The chord of parabola $y^2 = 4ax$ subtends a right angle at the vertex. Given that the coordinates of P and Q are $(at^2, 2at)$ and $(aT^2, 2aT)$ respectively. Prove that $tT + 4 = 0$ and that the locus of their point of intersection S of the normal at P and Q is given by $y^2 = 16x(x - 6a)$

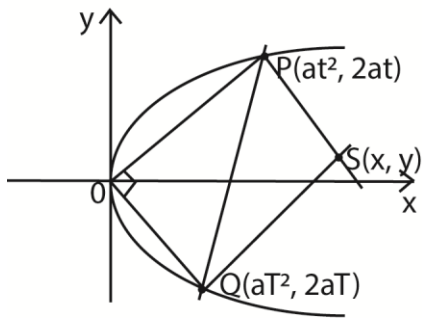

Since OP and OQ are perpendicular, the gradient of OP x gradient of OQ = -1

$$\frac{2at-0}{at^2-0} \cdot \frac{aT^2-0}{2aT-0} = -1$$

$$\frac{2}{t} \cdot \frac{2}{T} = -1$$

$$tT + 4 = 0 \text{ As required}$$

Eqn. of the normal at P:

$$tx + y = 2at + at^3 \dots\dots\dots(i)$$

Eqn. of the normal at Q:

$$Tx + y = 2aT + aT^3 \dots\dots\dots (ii)$$

Eqn. (i) – eqn.(ii)

$$(t - T)x = 2a(t - T) + a(t^3 - T^3)$$

$$(t - T)x = 2a(t - T) + a(t - T)(t^2 + tT + T^2)$$

$$x = 2a + a(t^2 + tT + T^2) \dots\dots\dots(iv)$$

Substituting x into eqn. (i)

$$2at + at(t^2 + tT + T^2) + y = 2at + at^3$$

$$atT(t + T) + y = 0$$

$$y = atT(t + T) \dots\dots\dots(iv)$$

Substituting for tT = -4 into eqn. (iv)

$$y = 4a(t + T)$$

$$\Leftrightarrow t + T = \frac{y}{4a}$$

$$\text{But } (t + T)^2 = t^2 + T^2 + 2tT$$

$$\text{i.e. } \left(\frac{y}{4a}\right)^2 = \frac{x+2a}{a} + 2(-4)$$

$$y^2 = 16a(x + 2a) - 16a^2(-8)$$

Please find free notes, tests and marking guides of physics, chemistry, biology and mathematics from: digitalteachers.co.ug

$$y^2 = 16a(x - 6a) \text{ as required}$$

(c) C is the midpoint of a variable chord PQ of the parabola. The tangents at P and Q meet at R. Prove that RC is parallel to the axis of the parabola.

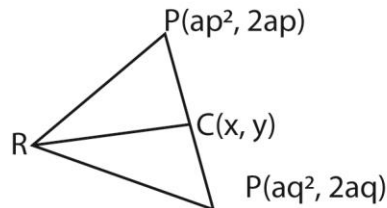

This means

$$x = \frac{1}{2}(ap^2 + aq^2) = \frac{1}{2}a(p^2 + q^2) \text{ and}$$

$$y = \frac{1}{2}(2ap + 2aq) = \frac{1}{2}a(p + q)$$

$$\therefore C\left[\frac{1}{2}a(p^2 + q^2), \frac{1}{2}a(p + q)\right]$$

The equations of the tangents at P and Q are

$$py = x + ap^2 \text{ and } qy = x + aq^2 \text{ respectively}$$

solving these simultaneously

$$x = apq \text{ and } y = a(p+q)$$

$$\therefore R(apq, a(p + q) \text{ for both.}$$

$$\therefore RC \text{ is parallel to the axis of the parabola } y = 0$$

The parabola with vertex at the point (h, k)

Suppose that the focus of the parabola is shifted by h horizontally and by k vertically, we have;

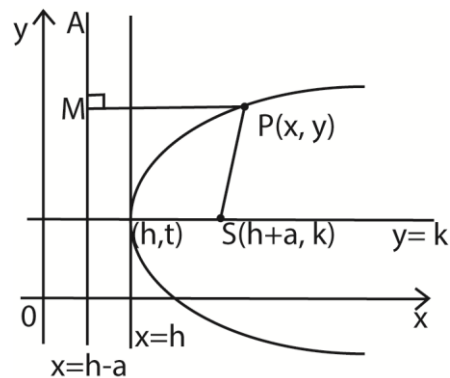

Using the definition of a parabola: $PS^2 = PM^2$

$$[x - (h + a)]^2 + (y - k)^2 = [x - (h - a)]^2$$

$$x^2 - 2(h+a)x + (h+a)^2 + (y-k)^2 = x^2 - 2(h-a)x + (h-a)^2$$

$$(y-k)^2 = 4a(x-h)$$

The above parabola has the following properties

- Vertex is at (h, k)
- Focus is at (h+a, k)
- Equation of the directrix, $x = h - a$
- Length of the latus rectum $2(2a + k)$

Example 14

- (a) Determine the coordinates of the vertex and the focus and the equation of the directrix of parabola $y^2 - 12x + 2y + 25 = 0$. Hence find the length of latus rectum

Solution

$$\Rightarrow y^2 + 2y = 12x - 25$$

$$(y + 1)^2 = 12x - 25 + 1$$

$$(y + 1)^2 = 12(x - 2)$$

i.e. $(y + 1)^2 = 4 \cdot 3(x - 2)$ in the form

$$(y - k)^2 = 4a(x - h)$$

$$\Rightarrow a = 3, k = -1, \text{ and } h = 2$$

The equation of the directrix is $x = -1$

$$\Rightarrow x = 2 - 3 = -1$$

Hence the equation of directrix is $x = -1$

The length of the latus rectum is

$$2(2a + k) = 2(6 - 1) = 10$$

- (b) Determine the equation of the parabola with the following respective vertexes and foci

- (i) (-1, 2) and (2, 2)

Solution

The required equations can be obtained from first principles using the definition of a parabola or using the general derived rule of $(y - k)^2 = 4a(x - h)$

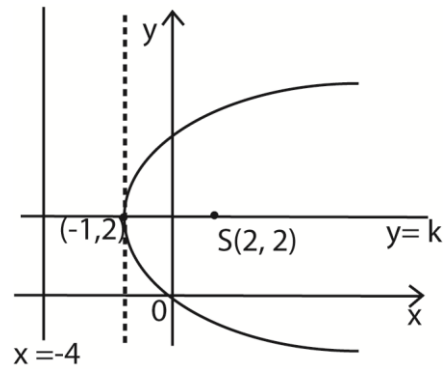

Using

$$(y - k)^2 = 4a(x - h)$$

For vertex = (-1, 2), $h = -1$ and $k = 2$

For focus S(2, 2), $h + a = -1 + a = 2$

$$\Rightarrow a = 3$$

by substitution,

$$(y - 2)^2 = 4 \times 3(x - (-1))$$

$$y^2 - 4y + 4 = 12(x + 1)$$

$$y^2 - 4y - 12x - 8 = 0$$

- (ii) (3, 4) and (3, -2)

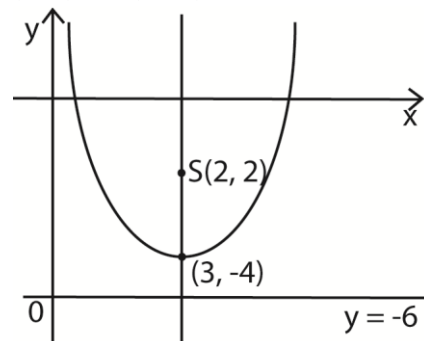

The distance from the vertex to the focus is 2 units. i.e. $a = 2$

$$(x - 3)^2 = 4(2)(y + 4)$$

$$\Rightarrow x^2 - 8y - 6x - 23 = 0$$

Note: the parabola of the form

$(x - h)^2 = 4a(y - k)$ has the vertex at (h, k) but its axis is parallel to the y-axis.

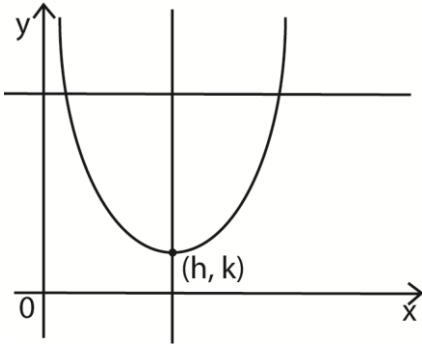

- (c) Find the equation of a parabola with a horizontal axis passing through (1, 4) and vertex (-2, 2). Hence find its focus and directrix.

Solution

$$\text{Using } (y - k)^2 = 4a(x - h)$$

For vertex, $(h, k) = (-2, 2)$, $h = -2$ and $k = 2$

By substitution

$$(y - 2)^2 = 4a(x - (-2))$$

Since the curve passes through (1, 4),

Substitute for $x = 1$ and $y = 4$.

$$(4 - 2)^2 = 4a(1 + 2)$$

$$4 = 12a$$

$$a = \frac{4}{12} = \frac{1}{3}$$

Substituting for h , k and a , the equation

$$\text{becomes } (y - 2)^2 = 4 \cdot \frac{1}{3}(x + 2)$$

$$\text{Or } y^2 + 12y - 4x + 6 = 0$$

Equation of directrix is $x = h - a$

$$\therefore x = -2 - \frac{1}{3} = -\frac{7}{3}$$

- (d) Find the focus and directrix of the parabola

$$y^2 = 8(x - 12)$$

Solution

Comparing $y^2 = 8(x - 12)$ with

$$(y - k)^2 = 4a(x - h)$$

$$\Rightarrow (y - 0)^2 = 4 \cdot 2(x - 12)$$

$$k = 0, a = 2 \text{ and } h = 12$$

Focus is $S(h+a, k) = S(14, 0)$

Hence $S(14, 0)$

Directrix is $h - a = 12 - 2 = 10$

Hence directrix is 10

- (e) A focal chord PQ, to the parabola $y^2 = 4x$, has a gradient $m = 1$. Find the coordinates of the mid-point of PQ. (05marks)

Solution

Method 1

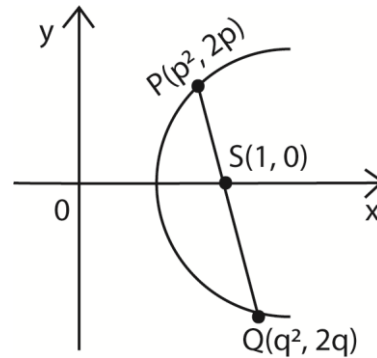

Gradient of PS = gradient of PQ = 1

$$\frac{2p-0}{p^2-1} = 1$$

$$p^2 - 2p - 1 = 0$$

$$p = \frac{2 \pm \sqrt{2^2 - 4(1)(-1)}}{2(1)} = \frac{2 \pm \sqrt{4+4}}{2} = 1 \pm \sqrt{2}$$

$$\Rightarrow P \left[(1 + \sqrt{2})^2, (2 + 2\sqrt{2}) \right],$$

$$Q \left[(1 - \sqrt{2})^2, (2 - 2\sqrt{2}) \right],$$

Let $M(x, y)$ be the coordinates of the mid-point of PQ.

$$x = \frac{1}{2} \left[(1 + \sqrt{2})^2, (2 + 2\sqrt{2}) \right] = 3$$

$$y = \frac{1}{2} \left[(1 - \sqrt{2})^2, (2 - 2\sqrt{2}) \right] = 2$$

$$\therefore M(3, 2)$$

Method 2

From $y^2 = 4x$, $a = 1$

$\therefore P(p^2, 2p)$ and $Q(q^2, 2q)$

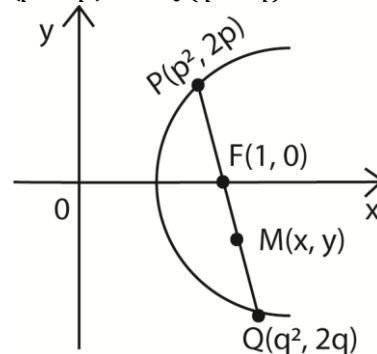

From focal chord, $pq = 1$

$$\begin{aligned} \text{Gradient} &= \frac{2q-2p}{q^2-p^2} = 1 \\ &= \frac{2(q-p)}{(q+p)(q-p)} = 1 \end{aligned}$$

$$\Rightarrow q + p = 2$$

$$M\left(\frac{p^2+q^2}{2}, p+q\right)$$

$$\begin{aligned} x &= \frac{p^2+q^2}{2} \\ &= \frac{1}{2}[(p+q)^2 - 2pq] \\ &= \frac{1}{2}[(-2)^2 - 2(1)] \\ &= \frac{1}{2}(4+2) = 3 \end{aligned}$$

$$y = p + q = 2$$

$$\therefore M(3, 2)$$

The point $P(at_1^2, 2at_1)$ and $Q(at_2^2, 2at_2)$ are on parabola $y^2 = 4ax$. OP is perpendicular to OQ , where O is the origin.

Show that $t_1t_2 + 4 = 0$.

Method 1

$$OP \cdot OQ = 0$$

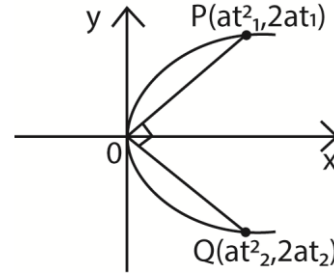

$$\text{Gradient of } OP, = m_1 = \frac{2at_1}{at_1^2} = \frac{2}{t_1}$$

$$\text{Gradient of } OQ = m_2 = \frac{2at_2}{at_2^2} = \frac{2}{t_2}$$

$$\text{But } m_1m_2 = -1$$

$$\frac{2}{t_1} \cdot \frac{2}{t_2} = -1$$

$$t_1t_2 + 4 = 0$$

Method 2

$$OP \cdot OQ = 0$$

$$\begin{pmatrix} at_1^2 \\ at_1 \end{pmatrix} \cdot \begin{pmatrix} at_2^2 \\ at_2 \end{pmatrix} = 0$$

$$at_1^2 \cdot at_2^2 + 2at_1 \cdot 2at_2 = 0$$

$$aa^2t_1t_2(t_1t_2 + 4) = 0$$

$$t_1t_2 + 4 = 0$$

Exercise 4

- Find the focus and directrix of the following parabolas
- Prove that the equation of the tangent at $(at^2, 2at)$ on the parabola $y^2 = 4ax$ is $x - ty + at^2 = 0$. A and B meet at P . The line PM is parallel to the axis of parabola and meets the line AB at M . Prove that M is the midpoint of AB . If the parameters of the point A and B are t and $2t$ respectively and the tangents meet at P , find the coordinates of P and show that it always lies on the parabola $2y^2 = 9ax$.
- Show that if the normal at $P(at^2, 2at)$ to the parabola $y^2 = 4ax$ meets the parabola again at $Q(aT^2, 2aT)$, $t^2 + tT + 2 = 0$. Hence show that the locus of the point of the tangents at P and Q is described by the curve $(x + 2a)y^2 + 4a^2 = 0$
- Show that O is the line $y = mx + d$ is a tangent to the parabola $y^2 = Ax + By + C$ if $d = \frac{1}{4mA} (A + Bm)^2 + \frac{cm}{A}$.
- Given that O is the vertex of the parabola $y^2 = 4ax$ and P is a point on the parabola, find the coordinates of the point of intersection of the normal and the perpendicular bisector of the line OP
- Prove that the equation of the tangent to the parabola $y^2 = 4ax$ at the point $(at^2, 2at)$ is $ty = x + at^2$. The tangent at P meets the y -axis at a point such that $FQPR$ is a parallelogram, find
 - the coordinates of $R(h+at^2, at)$
 - the equation of the locus of R $[y^2 = a(x-h), \text{ where } F(h,0) \text{ is the focus.}]$

7. (a) Show that the locus of the midpoint of the line joining the parabola $y^2 = 8x$ and the point $(8, 0)$ is a parabola.
 (b) Determine the point at which lines from the new focus are perpendicular to the parabola $y^2 = 8x$
 $[(1, 2\sqrt{2}) \text{ and } (1, -2\sqrt{2})]$
 (c) Find the y-coordinates of the point at which the tangent at one of the points meets the y-axis. $[\sqrt{2}]$
8. (a) Tangent from the point $T(t^2, 2t)$ touches the curve $y^2 = 4x$. Find
 (i) the equation of the tangent
 $[ty - x - t^2 = 0]$
 (ii) the equation of the line L parallel to the normal at $(t^2, 2t)$ and passing through $(1, 0)$. $[y + tx - t = 0]$
 (iii) the point of intersection X of the line L and the tangent. $[X(0, t)]$
 (b) A point $P(x, y)$ is equidistant from X and T. Show that the locus of P is
 $t^3 + 3t - 2(xt + y) = 0$
9. Prove that the tangents to the parabola $y^2 = 4ax$ at points $P(ap^2, 2ap)$ and $Q(aq^2, 2aq)$ meet at the point $T(apq, a(p+q))$
 (a) If M is the midpoint of PQ, prove that TM is bisected by the parabola
 (b) If P and Q vary on the parabola in such a manner that PQ is always parallel to the fixed line $y = mx$, show that T always lies on the fixed line parallel to x-axis
- $\left[\text{show that } y = \frac{2a}{m}; \text{ since } a \text{ and } m \text{ are constant, then } T \text{ lies a fixed line that is parallel to } x - \text{axis} \right]$
10. $P(ap^2, 2ap)$ and $Q(aq^2, 2aq)$ are two points on the parabola, $y^2 = 4ax$, PQ is a focal chord. Prove that $pq = -1$ and hence that if the tangents at P and Q intersect at T, the locus of T is given by $x + a = 0$. PM and QN are perpendiculars onto $x + a = 0$, $S = (a, 0)$. Prove that $\angle MSN = \angle PTQ = 90^\circ$.
11. (a) (i) Find the equation of the chord through the points $(at_1^2, 2at_1)$ and $(at_2^2, 2at_2)$ of the parabola $y^2 = 4at$.
 $[(t_1 + t_2)y - 2at_1t_2 = 0]$
 (ii) Show that the chord cuts the directrix when $y = \frac{2a(t_2t_1 - 1)}{t_1 + t_2}$
 (b) Find the equation of the normal to the parabola $y^2 = 4ax$ at $(at^2, 2at)$ and determine the point of intersection with the directrix. $[at(t^2 + 3), (a, at(t^2 + 3))]$
12. (a) Find the equation of the tangent to the parabola $y^2 = \frac{x}{16}$ at the point $(t^2, \frac{t}{4})$.
 (b) If the tangents to the parabola in (a) above at the point $(p^2, \frac{p}{4})$ and $(q^2, \frac{q}{4})$ meet on the line $y = 2$.
 (i) show that $p + q = 16$
 (ii) deduce that the midpoint of PQ lies on the line $y = 2$.

The Ellipse

An ellipse takes the form of an oval shape whose length is $2a$ and width $2b$.

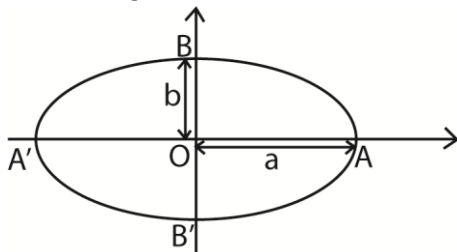

In conics, an ellipse is defined as a locus of all points of P such that the distance from P

to a fixed point (focus) bears a constant ratio $e (< 1)$ to the distance from P to a fixed line (the directrix).

Note

- O is the centre of the ellipse
- A'OA is the major axis of which $OA = OA'$ is the semi-major axis.
- B'OB is the minor axis in which $OB = OB'$ is the semi-minor axis.

Finding directrix and foci of an ellipse

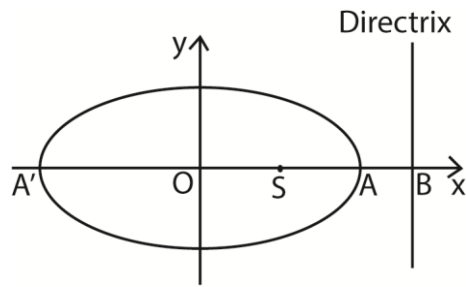

Let $OA = OA' = a$

Using the definition of a conic

At A: $AS = eAB$

$OS - OA = e(OB - OA)$

$a - s = e(b - a)$ (i)

At A': $A'S = eA'B$

$A'O - OS = e(A'O + OB)$

$a + s = e(b + a)$ (ii)

eqn. (i) + eqn. (ii)

$2s = 2ae; s = ae$

Now, for an ellipse above, there are other point S' and B' such that the same locus would be obtained with these as focus and point of directrix (L_2)

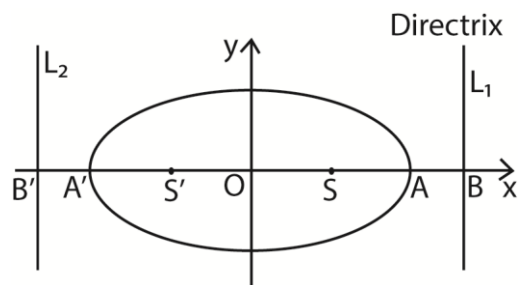

Hence the equation of the directrix are given as $x = \pm \frac{a}{e}$ and the coordinates of the foci are $(\pm ae, 0)$ where $0 < e < 1$

Equation of an ellipse

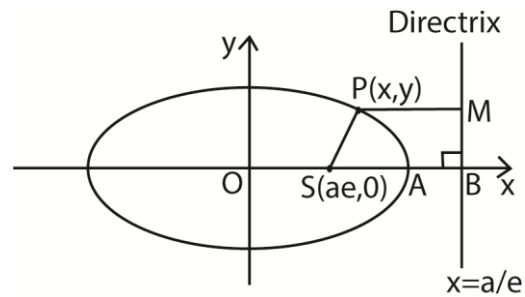

By definition

$$PS^2 = e^2 PM^2$$

$$(x - ae)^2 + y^2 = e^2 \left(\frac{a}{e} - x \right)^2$$

$$(1 - e^2)x^2 + y^2 = a^2(1 - e^2)$$

Dividing through by $a^2(1 - e^2)$

$$\frac{x^2}{a^2} + \frac{y^2}{a^2(1 - e^2)} = 1$$

$$\frac{x^2}{a^2} + \frac{y^2}{b^2} = 1$$

This is an equation of the ellipse with centre at the origin.

Bear in mind that an ellipse may be horizontal or vertical. However, the properties remain the same.

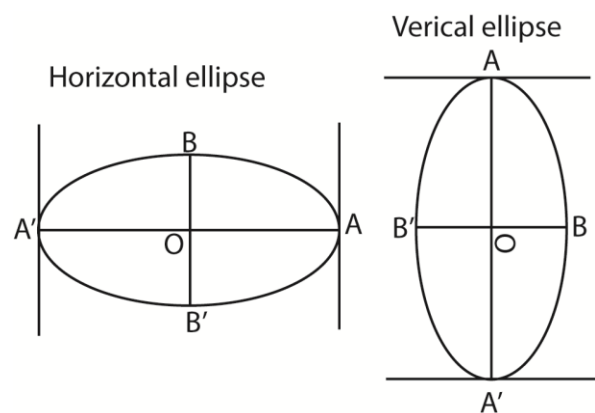

If $a > b$, the ellipse is horizontal and if $a < b$, the ellipse is vertical

Properties of an ellipse

- (i) If P is any point of the ellipse with foci F_1 and F_2 and length of the major axis $2a$.

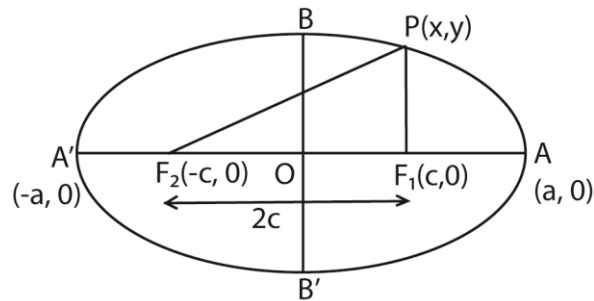

$$\text{Then } |F_1P| + |F_2P| = 2a$$

This property can be used to derive the equation of an ellipse as follows:

$$|F_1P| + |F_2P| = 2a$$

$$\sqrt{(x+c)^2 + (y-0)^2} + \sqrt{(x-c)^2 + (y-0)^2} = 2a$$

$$\sqrt{(x+c)^2 + y^2} + \sqrt{(x-c)^2 + y^2} = 2a$$

$$\sqrt{(x+c)^2 + y^2} = 2a - \sqrt{(x-c)^2 + y^2}$$

Squaring both sides and simplifying

$$cx - a^2 = -a\sqrt{(x-c)^2 + y^2}$$

squaring both sides again

$$(cx - a^2)^2 = a^2[(x-c)^2 + y^2]$$

$$(a^2 - c^2)x^2 + a^2y^2 = a^2(a^2 - c^2)$$

Dividing through by $a^2(a^2 - c^2)$

$$\frac{x^2}{a^2} + \frac{y^2}{a^2 - c^2} = 1$$

Taking $b^2 = a^2 - c^2$

$$c^2 = a^2 - b^2$$

$$c = \pm\sqrt{a^2 - b^2}$$

where $c = ae$

Note

By equating the two:

$$ae \pm \sqrt{a^2 - b^2}$$

$$a^2e^2 = a^2 - b^2$$

$$b^2 = a^2 - a^2e^2$$

$$b^2 = a^2(1 - e^2)$$

Hence this property is noteworthy using for derivation of the equation of an ellipse.

- (ii) The angles formed between the tangents to an ellipse and the lines through the foci are equal.

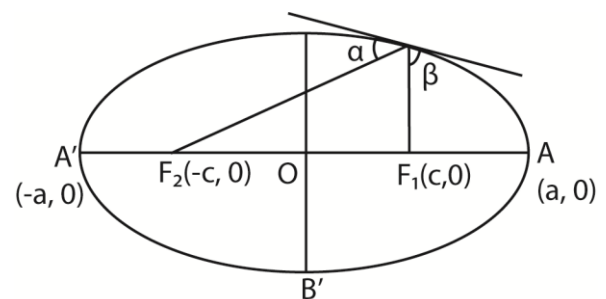

i.e. $\alpha = \beta$

Parametric equation of an ellipse

The equation $x = a\cos\theta$ and $y = b\sin\theta$ for a parameter θ , are used to represent a point on an ellipse. Where $0 \leq \theta \leq 2\pi$. Other parameters like α and β represent the points; i.e. $(a\cos\alpha, b\sin\alpha)$ and $(a\cos\beta, b\sin\beta)$ respectively.

Gradient of the tangent can also be obtained either parametrically or from the equations of given ellipse.

From the parameters:

$$X = a \cos\theta \text{ and } y = b\sin\theta$$

$$\frac{dx}{d\theta} = -a\sin\theta, \frac{dy}{d\theta} = b\cos\theta$$

$$\frac{dy}{dx} = \frac{-b\cos\theta}{a\sin\theta}$$

From the equation:

$$\frac{x^2}{a^2} + \frac{y^2}{b^2} = 1$$

$$\Rightarrow b^2x^2 + a^2y^2 = a^2b^2$$

Please find free notes, tests and marking guides of physics, chemistry, biology and mathematics from: digitalteachers.co.uk

$$2b^2x + 2a^2y \frac{dy}{dx} = 0$$

$$\frac{dy}{dx} = \frac{-b^2x}{a^2y}$$

At P(acosθ, bsinθ)

$$\frac{dy}{dx} = \frac{-bcosθ}{asinθ}$$

Equation of the tangent and normal

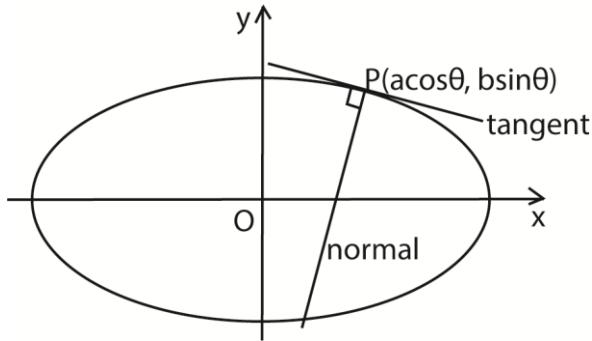

(a) Equation of the tangent at P(acosθ, bsinθ)

$$y - bsinθ = \frac{-bcosθ}{asinθ} (x - acosθ)$$

$$aysinθ - absin^2θ = -bxcosθ + abcos^2θ$$

$$bxcosθ + aysinθ = ab$$

$$\text{Or } \frac{x}{a} cosθ + \frac{y}{b} sinθ = 1$$

(b) Gradient of the normal at P(acosθ, bsinθ)

$$= \frac{asinθ}{bcosθ}$$

Equation of the normal at P(acosθ, bsinθ)

$$y - bsinθ = \frac{asinθ}{bcosθ} (x - acosθ)$$

$$bysinθ - b^2sinθcosθ = axsinθ - a^2sinθcosθ$$

$$axsinθ - bysinθ = (a^2 - b^2) sinθcosθ$$

Equation of the chord

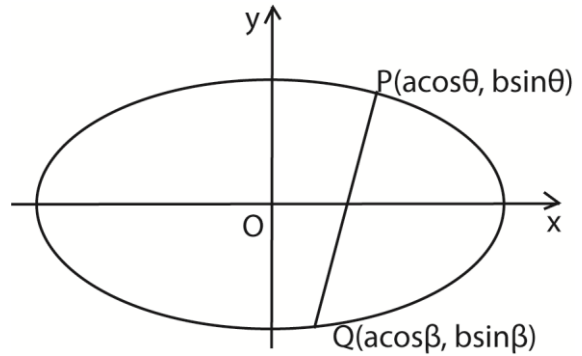

The equation of the chord joining the points P(acosθ, bsinθ) and Q(acosβ, bsinβ) can be obtained as follows

$$\text{Gradient of PQ} = \frac{b(sinβ - sinθ)}{a(cosβ - cosθ)}$$

For any point (x, y) on the chord

$$\frac{y - bsinθ}{x - acosθ} = \frac{b(sinβ - sinθ)}{a(cosβ - cosθ)}$$

Simplifying

$$bxcos \frac{1}{2}(\beta + \theta) + aysin \frac{1}{2}(\beta + \theta) = abcos \frac{1}{2}(\beta - \theta)$$

A line y = mx + c as a tangent to the ellipse

Equation of the line y = mx + c(i)

Equation of ellipse b²x² + a²y² = a²b²(ii)

Substituting eqn. (i) into eqn. (ii)

$$b^2x^2 + a^2(m^2x^2 + 2mcx + c^2) = a^2b^2$$

$$(b^2 + a^2m^2)x^2 + 2a^2mcx + a^2(c^2 - b^2) = 0$$

For equal roots

$$2a^2m^2c^2 - 4(b^2 + a^2m^2)a^2(c^2 - b^2)$$

$$b^2c^2 = b^2(b^2 + a^2m^2) \text{ i.e. } c^2 = b^2 + a^2m^2$$

∴ the line y = mx + c is a tangent to ellipse b²x² + a²y² = a²b² when c² = b² + a²m² and the line becomes y = mx ± √(b² + a²m²)

The length of the latus rectum

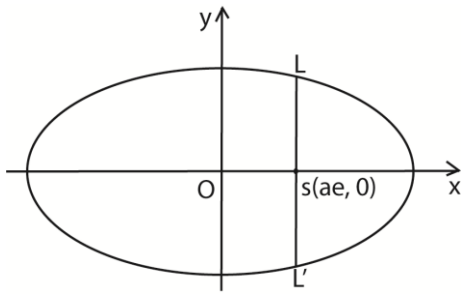

At L, $x = \pm ae$

Substituting for x into $b^2x^2 + a^2y^2 = a^2b^2$

$$b^2a^2e^2 + a^2y^2 = a^2b^2$$

$$y^2 = b^2(1 - e^2)$$

But for an ellipse, $b^2 = a^2(1 - e^2)$

$$\Rightarrow y^2 = b^2 \left(\frac{b^2}{a^2}\right) = \frac{b^4}{a^2}$$

$$y = \frac{b^2}{a}$$

The length of the latus rectum is

$$LL' = 2y = \frac{2b^2}{a}$$

Equation of the director circle

If two perpendicular tangents are drawn from a point P(x, y) to the ellipse $b^2x^2 + a^2y^2 = a^2b^2$, the locus of P as the points of contact vary is called a director circle.

The line of the tangent is

$$y = mx \pm \sqrt{b^2 + a^2m^2}$$

Squaring both sides:

$$y^2 - 2myx + m^2x^2 = b^2 + a^2m^2$$

$(a^2 - x^2)m^2 + 2xym + b^2 - y^2 = 0$; a quadratic in m.

If m_1 and m_2 are gradients of two tangents, then

Sum of roots = $m_1 + m_2 = \frac{-2xy}{a^2 - x^2}$ and product

of roots $m_1m_2 = \frac{b^2 - y^2}{a^2 - x^2}$

Since the tangents are perpendicular,

$$m_1m_2 = -1$$

$$\Rightarrow \frac{b^2 - y^2}{a^2 - x^2} = -1$$

$$b^2 - y^2 = x^2 - a^2 \text{ or } x^2 + y^2 = a^2 + b^2$$

This is the equation of the director circle.

Note: The centre of the director circle is the centre of the ellipse, O(0, 0) and its radius is $\sqrt{a^2 + b^2}$ units.

Example 15

(a) Show that the equation of the tangent to the ellipse $\frac{x^2}{a^2} + \frac{y^2}{b^2} = 1$ at P(x_1, y_1) is

$$\frac{xx_1}{a^2} + \frac{yy_1}{b^2} = 1$$

Solution

$$b^2x^2 + a^2y^2 = a^2b^2$$

Differentiating with respect to x

$$\frac{dy}{dx} = \frac{-b^2x}{a^2y}$$

Equation of the tangent at P(x_1, y_1)

$$y - y_1 = \frac{-b^2x}{a^2y_1}(x - x_1)$$

$$b^2xx_1 + a^2yy_1 = b^2x_1^2 + a^2y_1^2$$

Dividing through by a^2b^2 :

$$\frac{xx_1}{a^2} + \frac{yy_1}{b^2} = \frac{x_1^2}{a^2} + \frac{y_1^2}{b^2}$$

But $\frac{x_1^2}{a^2} + \frac{y_1^2}{b^2} = 1$

$$\Rightarrow \frac{xx_1}{a^2} + \frac{yy_1}{b^2} = 1$$

(b) Show that the two tangents of gradient m to the ellipse $\frac{x^2}{a^2} + \frac{y^2}{b^2} = 1$ are

$$y = mx \pm \sqrt{a^2m^2 + b^2}$$

Hence find the

(i) Equation of the tangents of the ellipse $\frac{x^2}{6} + \frac{y^2}{3} = 1$ from the point (-2, 5).

(ii) Coordinates of the points of contact of these tangents.

Solution

Let the equation of the line be

$$y = mx + c \dots\dots\dots(i)$$

and equation of the ellipse

$$b^2x^2 + a^2y^2 = a^2b^2 \dots\dots\dots(ii)$$

Solving simultaneously eqn. (i) and eqn. (ii) and applying $b^2 = 4ac$

$$c = \pm \sqrt{a^2m^2 + b^2}$$

Hence the equations of the tangents are

$$y = mx \pm \sqrt{a^2 m^2 + b^2}.$$

(i) Given that $\frac{x^2}{6} + \frac{y^2}{3} = 1 \Rightarrow a^2 = 6, b^2 = 3$

Substituting $a^2 = 6, b^2 = 3$ and

$$(x, y) = (-2, 5) \text{ into } y = mx \pm \sqrt{a^2 m^2 + b^2}$$

$$5 = -2m \pm \sqrt{6m^2 + 3}$$

$$5 + 2m = \pm \sqrt{6m^2 + 3}$$

Squaring both sides

$$25 + 20m + 4m^2 = 6m^2 + 3$$

$$m^2 - 10m - 11 = 0$$

$$m = -1 \text{ or } m = 11$$

$$\text{when } m = -1; y = -x \pm \sqrt{6(-1)^2 + 3}$$

$$y = -x \pm 3$$

$$\text{when } m = 11; y = -x \pm \sqrt{6(11)^2 + 3}$$

$$y = 11x \pm 27$$

Hence the calculated equations of the tangents are

$$y = -x - 3 \dots\dots\dots(i)$$

$$y = -x + 3 \dots\dots\dots(ii)$$

$$y = 11x - 27 \dots\dots\dots(iii)$$

$$y = 11x + 27 \dots\dots\dots(iv)$$

But only two of these equations are correct so we need to check in order to verify the correct equations.

Using points $(-2, 5) \Rightarrow x = -2$ and $y = 5$

Substituting into eqn. (i)

$$\text{LHS} = 5$$

$$\text{RHS} = 2 - 3 = -1$$

$\text{LHS} \neq \text{RHS}$, hence eqn. (i) is not correct

Substituting into eqn. (ii)

$$\text{LHS} = 5$$

$$\text{RHS} = 2 + 3 = 5$$

$\text{LHS} = \text{RHS}$, hence eqn. (ii) is correct

Substituting into eqn. (iii)

$$\text{LHS} = 5$$

$$\text{RHS} = -22 + 27 = 5$$

$\text{LHS} = \text{RHS}$, hence eqn. (iii) is correct

Substituting into eqn. (iv)

$$\text{LHS} = 5$$

$$\text{RHS} = -22 - 27 = -49$$

$\text{LHS} \neq \text{RHS}$, hence eqn. (iv) is not correct

Hence the equations of the tangents

are

$$y = -x + 3 \text{ and } y = 11x + 27$$

(ii) Method 1

Finding the gradient of the tangent to the curve at the points (x, y) .

$$\text{Differentiating } \frac{x^2}{6} + \frac{y^2}{3} = 1$$

$$\frac{2x}{6} + \frac{2y}{3} \cdot \frac{dy}{dx} = 0$$

$$\frac{dy}{dx} = -\frac{x}{2y}$$

$$\therefore \text{gradient} = -\frac{x}{2y}$$

For tangent $y = -x + 3$, gradient = -1

Equating the two;

$$-\frac{x}{2y} = -1$$

$$x = 2y$$

Substituting for x into $y = -x + 3$

$$y = -2y + 3$$

$$y = 1 \text{ and } x = 2$$

Hence the point of contact of the

tangent $y = -x + 3$ with ellipse is $(2, 1)$

For tangent $y = 11x + 27$, gradient = 11

Equating the two;

$$-\frac{x}{2y} = 11$$

$$x = -22y$$

Substituting for x into $y = -x + 3$

$$y = 11(-22y) + 27$$

$$y = \frac{1}{9} \text{ and } x = \frac{-22}{9}$$

Hence the point of contact of the

tangent $y = 11x + 27$ with ellipse is

$$\left(\frac{1}{9}, \frac{-22}{9}\right)$$

Method 2

Substituting the equation of the tangents in the equation of the ellipse

For tangent $y = -x + 3$

$$\frac{x^2}{6} + \frac{(-x+3)^2}{3} = 1$$

$$\frac{x^2}{6} + \frac{x^2 - 6x + 9}{3} = 1$$

$$x^2 - 4x + 4 = 0$$

At the point of contact $b^2 = 4ac$

$$x = \frac{-b}{2a} = \frac{4}{2} = 2$$

$$y = -2 + 3 = 1$$

Hence point of contact is (2, 1)

For tangent $y = 11x + 27$

$$\frac{x^2}{6} + \frac{(11x+27)^2}{3} = 1$$

$$\frac{x^2}{6} + \frac{121x^2 + 594x + 729}{3} = 1$$

$$81x^2 + 3964x + 484 = 0$$

At the point of contact $b^2 = 4ac$

$$x = \frac{-b}{2a} = \frac{-396}{162} = \frac{-22}{9}$$

$$y = 11\left(\frac{-22}{9}\right) + 27 = \frac{1}{9}$$

Hence point of contact is $\left(\frac{1}{9}, \frac{-22}{9}\right)$

- (c) (i) Show that the equation of the normal at point $P(a\cos\theta, b\sin\theta)$ to the ellipse

$$\frac{x^2}{a^2} + \frac{y^2}{b^2} = 1 \text{ is } ax\sin\theta - by\cos\theta = (a^2 - b^2)$$

Solution

From the parameters:

$$x = a \cos\theta \text{ and } y = b \sin\theta$$

$$\frac{dx}{d\theta} = -a\sin\theta, \frac{dy}{d\theta} = b\cos\theta$$

$$\text{Gradient of the tangent, } \frac{dy}{dx} = \frac{-b\cos\theta}{a\sin\theta}$$

But gradient of the tangent \times gradient of the normal = -1

Hence gradient of the normal at

$$P(a\cos\theta, b\sin\theta) = \frac{a\sin\theta}{b\cos\theta}$$

Equation of the normal at $P(a\cos\theta, b\sin\theta)$

$$y - b\sin\theta = \frac{a\sin\theta}{b\cos\theta}(x - a\cos\theta)$$

$$by\sin\theta - b^2\sin\theta\cos\theta = ax\sin\theta - a^2\sin\theta\cos\theta$$

$$ax\sin\theta - by\sin\theta = (a^2 - b^2)\sin\theta\cos\theta$$

- (ii) The normal at P meets line $x = a$ and $y = b$ axes at A and B respectively. Show that the area of the triangle OAB where O is the origin

$$\text{cannot exceed } \frac{(a^2 - b^2)}{4ab}.$$

Solution

At point A, $y = 0$

$$x = \frac{(a^2 - b^2)\cos\theta}{a} \Rightarrow A\left(\frac{(a^2 - b^2)\cos\theta}{a}, 0\right)$$

At B, $x = 0$

$$y = -\frac{(a^2 - b^2)\sin\theta}{a} \Rightarrow B\left(0, -\frac{(a^2 - b^2)\sin\theta}{a}\right)$$

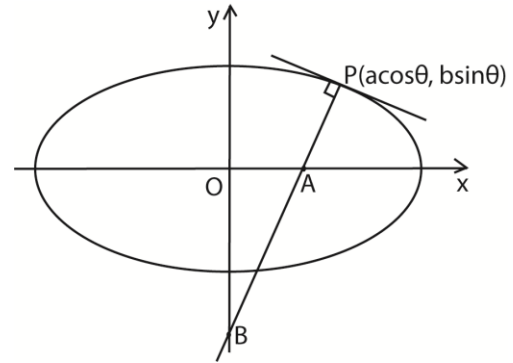

$$\begin{aligned} \text{Area of OAB} &= \frac{1}{2} |OA| |OB| \\ &= \frac{1}{2} \left[\frac{(a^2 - b^2)\cos\theta}{a} \right] \cdot \left[\frac{(a^2 - b^2)\sin\theta}{a} \right] \\ &= \frac{1}{2} \left[\frac{(a^2 - b^2)^2 \sin 2\theta}{2ab} \right] \\ &= \frac{1}{2} \left[\frac{(a^2 - b^2)\sin 2\theta}{4ab} \right] \end{aligned}$$

The area of a triangle is maximum when $\sin 2\theta = 1$ i.e. $-1 \leq \sin 2\theta \leq 1$

$$\therefore \text{Maximum area of the triangle} = \frac{(a^2 - b^2)}{4ab}.$$

- (iii) Find the equation of the locus of the centroid of triangle OAB.

Solution

Let $C(x, y)$ be the centroid of triangle OAB.

$$\Rightarrow x = \frac{1}{3} \cdot \frac{(a^2 - b^2)\cos\theta}{a}, \cos\theta = \frac{3ax}{a^2 - b^2}$$

$$\Rightarrow y = -\frac{1}{3} \cdot \frac{(a^2 - b^2)\sin\theta}{a} \Rightarrow \sin\theta = \frac{-3by}{a^2 - b^2}$$

Using $\cos^2\theta + \sin^2\theta = 1$

$$\left(\frac{3ax}{a^2 - b^2}\right)^2 + \left(\frac{-3by}{a^2 - b^2}\right)^2 = 1$$

$$9a^2x^2 + 9b^2y^2 = (a^2 - b^2)^2$$

\therefore the locus of the centroid is

$$9a^2x^2 + 9b^2y^2 = (a^2 - b^2)^2$$

- (d) A tangent to the ellipse $b^2x^2 + a^2y^2 = a^2b^2$ at point $P(a\cos\theta, b\sin\theta)$ meets the minor axis at L. If the normal at P meets the major axis at

M. Show that the locus of the midpoint of LM is given by the equation

$$4axy = (a - b)(a + b)\sqrt{(2y - b)(2y + b)}$$

Solution

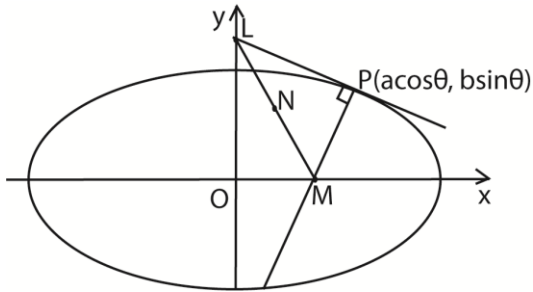

The equation of the tangent at P:

$$bx\cos\theta + aysin\theta = ab$$

$$\text{At } L \ x = 0, \text{ i.e. } y = \frac{b}{\sin\theta}$$

$$\therefore L\left(0, \frac{b}{\sin\theta}\right)$$

The equation of the normal at P

$$Ax\sin\theta - by\cos\theta = (a^2 - b^2)\sin\theta\cos\theta$$

$$\text{At } M, \ y = 0; \text{ i.e. } x = \frac{(a^2 - b^2)\cos\theta}{a}$$

$$\therefore M\left(\frac{(a^2 - b^2)\cos\theta}{a}, 0\right)$$

Let the midpoint of LM be N(x, y)

$$x = \frac{(a^2 - b^2)\cos\theta}{2a} \Rightarrow \cos\theta = \frac{2ax}{(a^2 - b^2)}$$

$$y = \frac{b}{2\sin\theta} \Rightarrow \sin\theta = \frac{b}{2y}$$

$$\text{From } \cos^2\theta + \sin^2\theta = 1$$

$$\left(\frac{2ax}{(a^2 - b^2)}\right)^2 + \left(\frac{b}{2y}\right)^2 = 1$$

$$\therefore 4axy = (a - b)(a + b)\sqrt{(2y - b)(2y + b)}$$

The general equation of an ellipse with centre (h, k)

If the centre of an ellipse is at point (h, k), the general equation is given by

$$\frac{(x-h)^2}{a^2} + \frac{(y-k)^2}{b^2} = 1$$

Note

- (i) For $a > b$, the ellipse is horizontal and the focus is on horizontal axis at $(h \pm c, k)$ with vertices at $(h \pm a, k)$ and $(h, k \pm b)$ where $c = ae$ or $c = a^2 - b^2$.
- (ii) For $a < b$, the ellipse is vertical and the focus is on vertical axis at $(h, k \pm c)$ with vertices at $(h \pm a, k)$ and $(h, k \pm b)$ where $c = ae$ or $c = a^2 - b^2$.

Example 16

(a) Express each of the following ellipses in the form

$$\frac{(x-h)^2}{a^2} + \frac{(y-k)^2}{b^2} = 1$$

(i) $9x^2 + 16y^2 - 36x + 96y - 36 = 0$

Solution

$$9(x^2 - 4x) + 16(y^2 + 6y) = -36$$

$$9(x - 2)^2 + 16(y + 3)^2 = -36 + 36 + 144$$

$$9(x - 2)^2 + 16(y + 3)^2 = 144$$

Dividing through by 144

$$\frac{(x-2)^2}{4^2} + \frac{(y+3)^2}{3^2} = 1$$

(ii) $16x^2 + 9y^2 - 64x + 54y + 1 = 0$

Solution

$$16(x^2 - 4x) + 9(y^2 + 6y) = -1$$

$$16(x - 2)^2 + 9(y + 3)^2 = -1 + 64 + 81$$

$$16(x - 2)^2 + 9(y + 3)^2 = 144$$

Dividing through by 144

$$\frac{(x-2)^2}{3^2} + \frac{(y+3)^2}{4^2} = 1$$

(iii) $25x^2 + 16y^2 + 100x - 300 = 0$

$$25(x^2 + 4x) + 16(y^2 + 0) = 300$$

$$25(x + 2)^2 + 16y^2 = 300 + 100 = 400$$

Dividing through by 400

$$\frac{(x+2)^2}{4^2} + \frac{y^2}{5^2} = 1$$

(b) Find the centre, foci and vertices of each of the following ellipse in (a).

(i) From $\frac{(x-2)^2}{4^2} + \frac{(y+3)^2}{3^2} = 1$

$$a = 4, \ b = 3, \text{ since } a > b$$

$$\Rightarrow c = \sqrt{a^2 - b^2} = \sqrt{4^2 - 3^2} = \sqrt{7},$$

$$h = 2 \text{ and } k = -3$$

$$\text{centre } (h, k) = (2, -3)$$

$$\text{Foci: } (h \pm c, k) = (2 \pm \sqrt{7}, -3)$$

$$\text{Vertices: } (h \pm a, k) = (2 \pm 4, -3)$$

$$\text{And } (h, k \pm b) = (2, -3 \pm 4)$$

Hence the vertices are $(6, -3)$, $(-2, -3)$, $(2, 0)$ and $(2, -6)$

Sketch

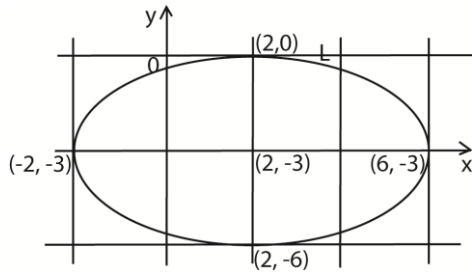

(ii) From $\frac{(x-2)^2}{3^2} + \frac{(y+3)^2}{4^2} = 1$

$a = 3$, $b = 4$, since $b > a$

$\Rightarrow c = \sqrt{b^2 - a^2} = \sqrt{4^2 - 3^2} = \sqrt{7}$,

$h = 2$ and $k = -3$

centre $(h, k) = (2, -3)$

Foci: $(h, k \pm c) = (2, -3 \pm \sqrt{7})$

Vertices: $(h \pm a, k) = (2 \pm 3, -3)$

And $(h, k \pm b) = (2, -3 \pm 4)$

Hence the vertices are $(5, -3)$, $(-1, -3)$, $(2, 1)$ and $(2, -7)$

Sketch

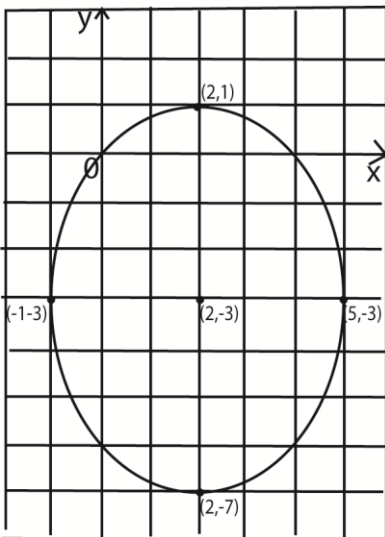

(iii) From $\frac{(x+2)^2}{4^2} + \frac{y^2}{5^2} = 1$

$a = 4$, $b = 5$, since $b > a$

$\Rightarrow c = \sqrt{b^2 - a^2} = \sqrt{5^2 - 4^2} = 3$,

$h = -2$ and $k = 0$

centre $(h, k) = (-2, 0)$

Foci: $(h, k \pm c) = (-2, \pm 3) = (-2, 3), (-2, -3)$

Vertices: $(h \pm a, k) = (-2 \pm 4, 0)$

And $(h, k \pm b) = (-2, 0 \pm 5)$

Hence the vertices are $(2, 0)$, $(-6, 0)$, $(-2, 5)$ and $(-2, -5)$

Sketch

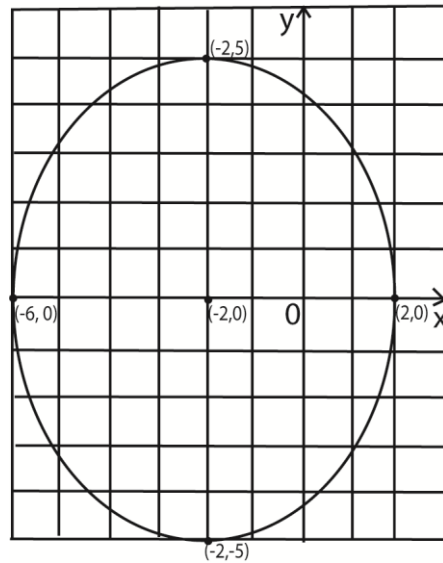

Exercise 5

- Given the parametric equation $x = 1 + 4\cos\theta$, and $y = 2 + 3\sin\theta$
 - Show that the curve represented the equations is an ellipse.
 - State the coordinates of the centre and the length of the semi-axes
 $[(1, 2), a = 4 \text{ and } b = 3]$
 - Find the equation of the tangent to ellipse at the point $(1+4\cos\theta, 2+3\sin\theta)$
- The normal at a point $(4\cos\theta, 2 + 3\sin\theta)$ on the ellipse $9x^2 + 16y^2 = 144$ meets the x- and y- axes at A and B. Show that the locus of M, the midpoint of AB, is an ellipse with the same concentricity as the given ellipse.
 $[e = \pm \frac{\sqrt{7}}{4}]$
- Show that the two tangents of gradient m to the ellipse $\frac{x^2}{a^2} + \frac{y^2}{b^2} = 1$ are
 $y = mx \pm \sqrt{(a^2m^2 + b^2)}$
 - Find
 - the equations of the grant m to the ellipse $\frac{x^2}{6} + \frac{y^2}{3} = 1$ from point (-2, 5)
 $[y = -x + 3, y = 11x + 27]$
 - the coordinates of the points of contact of these tangents.
 $[(2,1) \text{ and } (\frac{-22}{9}, \frac{1}{9})]$
- The coordinates of a point P(x, y) on the curve are given parametrically by the equation $x = a\cos\theta$, $y = b\sin\theta$ where a and b are constant and θ is the parameter.
 Find
 - Cartesian equation for the curve and identify the curve
 $[\frac{x^2}{a^2} + \frac{y^2}{b^2} = 1, \text{ ellipse}]$
 - equation of the tangent to the curve at the point where the parameter is $\theta = \alpha$
 $[aysina + bxcosa - ab = 0]$
 - relationship between α_1 and α_2 if the tangents at the points $(a\cos\alpha_1, b\sin\alpha_1)$ and $(a\cos\alpha_2, b\sin\alpha_2)$ are at right angles to each other.
 $[\tan \alpha_1 \tan \alpha_2 = \frac{b^2}{a^2}]$
- A conic section is given by $x = 4\cos\theta$; $y = 3\sin\theta$. Show that the conic section is an ellipse and determine its eccentricity.
 $[Eqn. \frac{x^2}{4^2} + \frac{y^2}{3^2} = 1, \text{ ellipse}, e = \frac{\sqrt{7}}{4}]$
 - Given that the line $y = mx + c$ is a tangent to the ellipse $\frac{x^2}{a^2} + \frac{y^2}{b^2} = 1$, show that $c^2 = a^2m^2 + b^2$. Hence determine the equation s of the tangents at the point (-3, 3) to the ellipse $\frac{x^2}{16} + \frac{y^2}{9} = 1$.
 $[y = 3 \text{ and } y = \frac{18}{7}x + \frac{75}{7}]$
- Show that the line $5y = 4x + 25$ is a tangent to the ellipse $\frac{x^2}{25} + \frac{y^2}{9} = 1$
 - Find the equation of the normal to the ellipse at the point of contact.
 $[y = \frac{-5}{4}x - \frac{16}{5}]$
 - Determine the eccentricity of the ellipse
 $[e = \frac{16}{25}]$
- Find the equation of the tangent and the normal to the ellipse $\frac{x^2}{4} + \frac{y^2}{1} = 1$ at the point P(2cos θ , sin θ).

$$\left[\begin{array}{l} \text{tangent line: } \frac{x}{2}\cos\theta + y\sin\theta = 1 \\ \text{normal line: } \frac{2}{3}x\sec\theta - \frac{1}{3}y\csc\theta = 1 \end{array} \right]$$
 - If the tangent in (a) cuts the y-axis at point A and x-axis at point B, and the normal cuts the x-axis at point C, find the coordinates of the points A, B and C.
 $[A(0, \csc\theta), B(2\sec\theta, 0), C(1.5\cos\theta, 0)]$

8. (a)(i) Find the coordinates of the points where the ellipse $\frac{x^2}{4} + \frac{y^2}{9} = 1$ cuts the axes [(0, -3), (0, 3), (-2, 0) and (2, 0)]
- (ii) Express the given equation in (a)(i) above, in its polar form [(3cos θ , 2sin θ)]
- (b) If the line $y = mx + c$ is a tangent to the ellipse $\frac{x^2}{4} + \frac{y^2}{9} = 1$, show that $c^2 = 4m^2 + 9$
9. The line $y = mx + c$ is a tangent to the ellipse $\frac{x^2}{a^2} + \frac{y^2}{b^2} = 1$ when $c = \pm\sqrt{a^2m^2 + b^2}$. Find the equations of the tangents to the ellipse $\frac{x^2}{4} + \frac{y^2}{1} = 1$ from the point (0, $\sqrt{5}$) [$y = \pm x + \sqrt{5}$]
10. The line $y = mx + c$ is a tangent to the ellipse $\frac{x^2}{a^2} + \frac{y^2}{b^2} = 1$ (06mars)
- (a) Obtain an expression for c in terms of a , b and m . (06mars)
- $$[c^2 = a^2m^2 + b^2]$$

- (b) Calculate the gradients of the tangents to the ellipse through the point $(\sqrt{(a^2 + b^2)}, 0)$ [$m \pm 1$]

11. P is a point (acos β , bsin β) on the ellipse $\frac{x^2}{a^2} + \frac{y^2}{b^2} = 1$. The normal at P to the ellipse meets the x-axis at Q. Show that the locus of the midpoint of PQ is an ellipse whose semi-axes are $(\frac{2a^2 - b^2}{2a})$ and $\frac{b}{2}$.
12. Show that the tangents to the ellipse $\frac{x^2}{a^2} + \frac{y^2}{b^2} = 1$ at the points whose eccentric angles differ by 90 $^\circ$ meet on the ellipse $\frac{x^2}{a^2} + \frac{y^2}{b^2} = 2$
13. Show that the equation to the chord joining the two points whose eccentric angles are α, β on the ellipse $\frac{x^2}{a^2} + \frac{y^2}{b^2} = 1$ is $\frac{x}{a} \cos \frac{1}{2}(\alpha + \beta) + \frac{y}{b} \sin \frac{1}{2}(\alpha + \beta) = \cos \frac{1}{2}(\alpha - \beta)$

The hyperbola

Hyperbola is defined as the locus of all points P such that the distance from P to a fixed point (focus) bears a constant ratio e to the distance from P to a fixed line (the directrix) where $e > 1$.

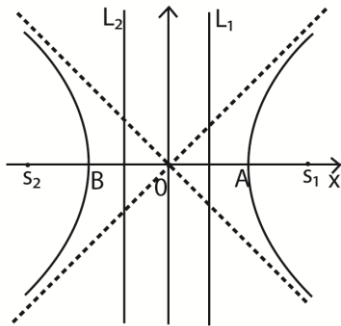

Just like for an ellipse, with hyperbola there is another point S_2 and line L_2 such that the same locus would be obtained with these as focus and directrix.

Note

- A and B are the vertices of the hyperbola
- O is the centre of the hyperbola

- $|AB|$ is the length of the axis and equal to $2a$
- s_1 and s_2 are the foci of hyperbola.

Finding directrix and foci of the hyperbola

These are derived in the same way as for ellipse.

The foci have coordinates $s_1(ae, 0)$ and $s_2(-ae, 0)$

The directrix have equations $x = \pm \frac{a}{e}$

Equation of the hyperbola

Considering only one arm of the hyperbola.

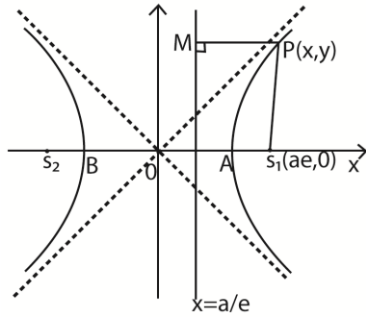

By definition:

$$PS = ePM$$

$$PS^2 = e^2PM^2$$

$$(x - ae)^2 + y^2 = e^2 \left(x - \frac{a}{e}\right)^2$$

$$(e^2 - 1)x^2 - y^2 = a^2(e^2 - 1)$$

$$\frac{x^2}{a^2} - \frac{y^2}{a^2(e^2 - 1)} = 1$$

$$\text{Taking } b^2 = a^2(e^2 - 1)$$

$$\frac{x^2}{a^2} - \frac{y^2}{b^2} = 1$$

Unlike for an ellipse, it is not necessary for a to be greater than b .

Finding the asymptotes

These are lines that cannot be crossed by a given curve. As shown above the hyperbola cannot cross the dotted lines

$$\text{From } \frac{x^2}{a^2} - \frac{y^2}{b^2} = 1$$

$$\Rightarrow \frac{y^2}{b^2} = \frac{x^2}{a^2} - 1$$

$$y^2 = \frac{b^2x^2}{a^2} - b^2$$

$$y^2 = \frac{b^2x^2}{a^2} \left(1 - \frac{a^2}{x^2}\right)$$

$$y = \pm \frac{bx}{a} \sqrt{\left(1 - \frac{a^2}{x^2}\right)}$$

As $x \rightarrow \infty$, $\frac{a^2}{x^2} \rightarrow 0$ thus, $y = \pm \frac{bx}{a}$

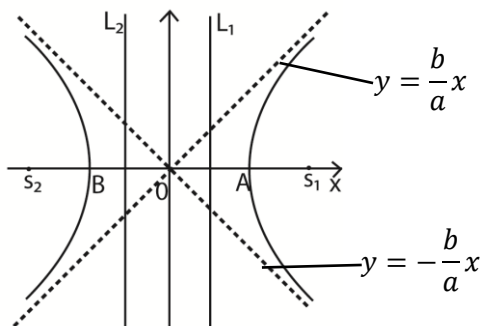

Parametric equation of a hyperbola

The parameter $x = a \sec \theta$ and $y = b \tan \theta$ for parameter θ are used, where $0 \leq \theta \leq 2\pi$

Equation of the tangent and normal

- (a) The equation of the tangent to the hyperbola at $P(a \sec \theta, b \tan \theta)$

Method 1

Parametrically:

$$\frac{dx}{d\theta} = a \sec \theta \tan \theta \text{ and } \frac{dy}{d\theta} = b \sec^2 \theta$$

$$\frac{dy}{dx} = \frac{dy}{d\theta} \cdot \frac{d\theta}{dx} = \frac{b \sec^2 \theta}{a \sec \theta \tan \theta} = \frac{b \sec \theta}{a \tan \theta}$$

At point $P(a \sec \theta, b \tan \theta)$

$$y - b \tan \theta = \frac{b \sec \theta}{a \tan \theta} (x - a \sec \theta)$$

$$a y \tan \theta - a b \tan^2 \theta = b x \sec \theta - a b \sec^2 \theta$$

$$b x \sec \theta - a y \tan \theta = ab \text{ (since } \sec^2 \theta - \tan^2 \theta = 1)$$

Method 2

The gradient can also be obtained by differentiating the equation of the hyperbola

$$b^2x^2 - a^2y^2 = a^2b^2$$

$$2b^2x - 2a^2y \frac{dy}{dx} = 0 \text{ Or } \frac{dy}{dx} = \frac{b^2x}{a^2y}$$

At point $P(a \sec \theta, b \tan \theta)$

$$y - b \tan \theta = \frac{b \sec \theta}{a \tan \theta} (x - a \sec \theta)$$

$$a y \tan \theta - a b \tan^2 \theta = b x \sec \theta - a b \sec^2 \theta$$

$$b x \sec \theta - a y \tan \theta = ab \text{ (since } \sec^2 \theta - \tan^2 \theta = 1)$$

- (b) The equation of the normal:

$$y - b \tan \theta = \frac{a \tan \theta}{b \sec \theta} (x - a \sec \theta)$$

$$a x \cos \theta + b y \tan \theta = a^2 + b^2$$

Equation of the chord to the hyperbola

Let $P(a \sec \theta, b \tan \theta)$ and $Q(a \sec \beta, b \tan \beta)$ be two points on the hyperbola.

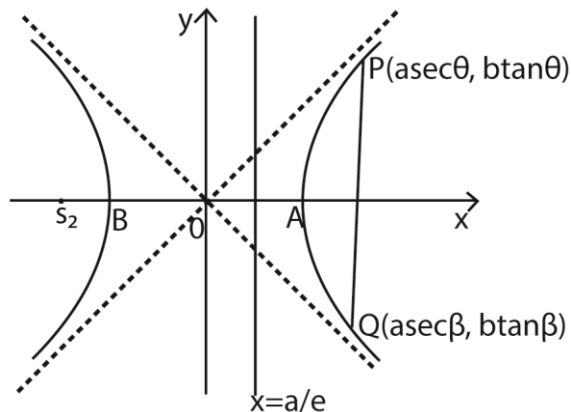

Equation of chord PQ:

$$\text{Gradient of PQ} = \frac{b(\tan\beta - \tan\theta)}{a(\sec\beta - \sec\theta)}$$

Equation of PQ:

$$y - b\tan\theta = \frac{b(\tan\beta - \tan\theta)}{a(\sec\beta - \sec\theta)}(x - a\sec\theta)$$

Simplifying

$$ay(\cos\beta - \cos\theta) - ab\tan\theta(\cos\beta - \cos\theta)$$

Example 17

- (a) Prove that the line $y = mx \pm \sqrt{m^2 - 1}$ are tangents to the hyperbola $x^2 - y^2 = a^2$ for all values of m .

Solution

Let $y = mx + c$ be a tangent to $x^2 - y^2 = a^2$

Substituting for y into the equation of hyperbola

$$x^2 - m^2x^2 - 2mcx - c^2 = a^2$$

$$(1 - m^2)x^2 - 2mcx - (a^2 + c^2) = 0$$

For tangency: $b^2 = 4ac$

$$m^2c^2 = a^2m^2 + m^2c^2 - a^2 - c^2$$

$$a^2 + c^2 = a^2m^2 \text{ i.e. } c = a^2m^2 - a^2$$

Substituting for c into $y = mx + c$.

$$y = mx \pm \sqrt{m^2 - 1}$$

- (b) Show that the asymptotes of a hyperbola are given by $y = \pm \frac{b}{a}x$

$$\text{From } \frac{x^2}{a^2} - \frac{y^2}{b^2} = 1$$

$$\Rightarrow \frac{y^2}{b^2} = \frac{x^2}{a^2} - 1$$

$$y^2 = \frac{b^2x^2}{a^2} - b^2$$

$$y^2 = \frac{b^2x^2}{a^2} \left(1 - \frac{a^2}{x^2}\right)$$

$$y = \pm \frac{bx}{a} \sqrt{\left(1 - \frac{a^2}{x^2}\right)}$$

As $x \rightarrow \infty$, $\frac{a}{x} \rightarrow 0$ thus, $y = \pm \frac{bx}{a}$

- (c) The tangent at $P(a\sec\theta, b\tan\theta)$ on hyperbola cuts the asymptote at A and B. Show that $PA = PB$

$$\text{AT A: } y = \frac{bx}{a}$$

Substituting for y into the equation of tangent: $bx\sec\theta - ay\tan\theta = ab$

$$bx\sec\theta - bxtan\theta = ab$$

$$x(\sec\theta - \tan\theta) = ab \text{ i.e. } x = \frac{a}{\sec\theta - \tan\theta}$$

Substituting for x into $y = \frac{bx}{a}$

$$y = \frac{b}{\sec\theta - \tan\theta}$$

$$\therefore A \left(\frac{a}{\sec\theta - \tan\theta}, \frac{b}{\sec\theta - \tan\theta} \right)$$

$$\text{AT B: } y = -\frac{bx}{a}$$

Substituting for y into the equation of tangent: $bx\sec\theta - ay\tan\theta = ab$

$$bx\sec\theta + bxtan\theta = ab$$

$$x(\sec\theta + \tan\theta) = ab \text{ i.e. } x = \frac{a}{\sec\theta + \tan\theta}$$

Substituting for x into $y = -\frac{bx}{a}$

$$y = \frac{-b}{\sec\theta + \tan\theta}$$

$$\therefore B \left(\frac{a}{\sec\theta + \tan\theta}, \frac{-b}{\sec\theta + \tan\theta} \right)$$

When $PA = PB$, then P must be the midpoint of AB.

Taking the x - coordinates of A and B

$$x = \frac{1}{2} \left(\frac{a}{\sec\theta - \tan\theta} + \frac{a}{\sec\theta + \tan\theta} \right)$$

$$= \frac{1}{2} \left(\frac{2a\sec\theta}{\sec^2\theta - \tan^2\theta} \right) = \frac{a\sec\theta}{1} = a\sec\theta$$

$x = a\sec\theta$ which is the x -coordinate of P.

$\therefore PA = PB$

The rectangular hyperbola

This is a special locus of hyperbola which occurs when the asymptotes of the hyperbola are perpendicular. It rises when the hyperbola is rotated through an angle of $+45^\circ$, about the origin.

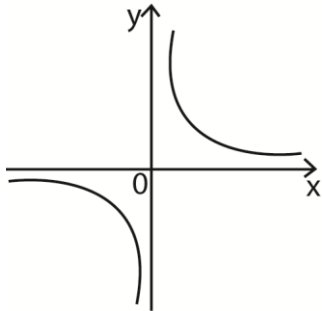

The asymptotes of the rectangular hyperbola are the x- and y-coordinate axes

Equation of the rectangular hyperbola

Given the equation of the hyperbola

$$\frac{x^2}{a^2} - \frac{y^2}{b^2} = 1 \text{ with asymptotes } y = \pm \frac{b}{a}x:$$

When the asymptotes are perpendicular, the product of their gradient is -1

$$\frac{b}{a}x - \frac{b}{a} = -1$$

$$\frac{-b^2}{a^2} = -1$$

$$a^2 = b^2$$

Substituting for b^2 into $\frac{x^2}{a^2} - \frac{y^2}{b^2} = 1$

$$\frac{x^2}{a^2} - \frac{y^2}{a^2} = 1$$

$$\frac{x^2 - y^2}{a^2} = 1$$

$x^2 - y^2 = a^2$ which is a simple equation of resulting hyperbola.

This equation can be expressed as

$$(x - y)(x + y) = a^2 \dots\dots\dots(i)$$

Its eccentricity, e can be obtained by substituting for b^2 into $b^2 = a^2(e^2 - 1)$.

$$\Rightarrow a^2 = a^2(e^2 - 1).$$

$$e^2 = 2 \text{ i.e. } e = \pm\sqrt{2}$$

Note; the matrix of the transformation about the origin through angle θ is given by

$$M = \begin{pmatrix} \cos\theta & -\sin\theta \\ \sin\theta & \cos\theta \end{pmatrix}$$

Therefore, the matrix, M for above rotation is given as

$$M = \begin{pmatrix} \cos 45^\circ & -\sin 45^\circ \\ \sin 45^\circ & \cos 45^\circ \end{pmatrix}$$

$$= \begin{pmatrix} \frac{\sqrt{2}}{2} & -\frac{\sqrt{2}}{2} \\ \frac{\sqrt{2}}{2} & \frac{\sqrt{2}}{2} \end{pmatrix}$$

$$= \frac{\sqrt{2}}{2} \begin{pmatrix} 1 & -1 \\ 1 & 1 \end{pmatrix}$$

A specific point P(x, y) is thus mapped onto P'(x', y') by M.

$$\therefore M(x, y) \rightarrow M'(x', y')$$

$$\Rightarrow \begin{pmatrix} x' \\ y' \end{pmatrix} = \frac{\sqrt{2}}{2} \begin{pmatrix} 1 & -1 \\ 1 & 1 \end{pmatrix} \begin{pmatrix} x \\ y \end{pmatrix}$$

$$\begin{pmatrix} x' \\ y' \end{pmatrix} = \frac{\sqrt{2}}{2} \begin{pmatrix} x - y \\ x + y \end{pmatrix}$$

$$\Rightarrow x' = \frac{\sqrt{2}}{2}(x - y)$$

$$\sqrt{2}x' = (x - y)$$

$$y' = \frac{\sqrt{2}}{2}(x + y)$$

$$\sqrt{2}y' = (x + y)$$

Substituting for $x - y$ and $x + y$ into eqn. (i)

$$\sqrt{2}x' \cdot \sqrt{2}y' = a^2$$

$$2x'y' = a^2$$

$$x'y' = \frac{1}{2}a^2$$

$$\text{Taking } c^2 = \frac{1}{2}a^2$$

$$\Rightarrow x'y' = c^2$$

Hence for any point (x, y) , the equation of rectangular hyperbola is $xy = c^2$ with $e = \pm\sqrt{2}$

Parametric equations

A typical point on the rectangular hyperbola can be represented as $P(ct, c/t)$ for a parameter t or $Q(cT, c/T)$ for a parameter T .

Gradient of the tangent

Parametrically for a point $P(ct, c/t)$

$$x = ct \text{ and } y = c/t$$

$$\frac{dx}{dt} = c, \frac{dy}{dt} = -\frac{c}{t^2}$$

$$\frac{dy}{dx} = \frac{dy}{dt} \cdot \frac{dt}{dx} = -\frac{c}{t^2} \cdot \frac{1}{c} = -\frac{1}{t^2}$$

Otherwise from the equation $xy = c^2$

$$\Rightarrow \frac{d}{dx}(xy) = \frac{d}{dx}(c^2)$$

$$y + x \frac{dy}{dx} = 0 \text{ (Using product rule)}$$

$$\frac{dy}{dx} = -\frac{y}{x}$$

$$\text{At } P(ct, c/t), \frac{dy}{dx} = -\frac{c}{t} \cdot \frac{1}{ct} = -\frac{1}{t^2}$$

Equations of the tangent and the normal

The equation of the tangent $P(ct, c/t)$

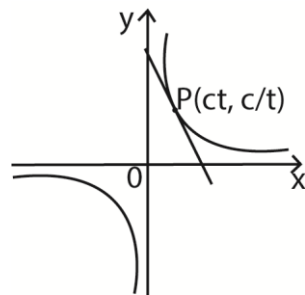

$$\frac{y - \frac{c}{t}}{x - ct} = -\frac{1}{t^2}$$

$$y - \frac{c}{t} = -\frac{1}{t^2}(x - ct)$$

$$t^2y - ct = -x + ct \text{ or } x + t^2y = 2ct$$

Equation of the normal

$$\frac{y - \frac{c}{t}}{x - ct} = t^2$$

$$y - \frac{c}{t} = t^2(x - ct)$$

$$ty + ct^4 = t^3x + c$$

Equation of the chord

Given the point $P(ct, c/t)$ and $Q(cT, c/T)$ on the hyperbola $xy = c^2$

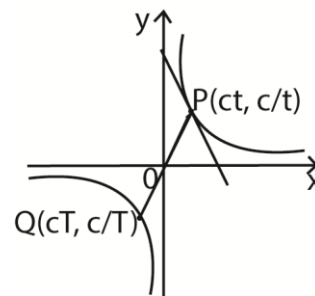

Gradient of PQ

$$\frac{\frac{c}{T} - \frac{c}{t}}{cT - ct} = \frac{t - T}{tT(T - t)} = \frac{-(T - t)}{tT(T - t)} = -\frac{1}{tT}$$

Equation of chord

$$y - \frac{c}{t} = -\frac{1}{tT}(x - ct)$$

$$x + tTy = c(t + T)$$

Note; the hyperbola $xy = -c^2$ lies in the second and fourth quadrants as shown below

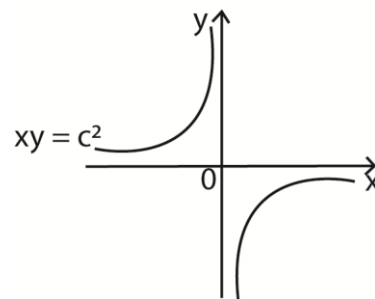

Example 18

1. (a) Find the equation of the tangent to the hyperbola whose points are of the parametric form $(2t, \frac{2}{t})$.

$$x = 2t, y = \frac{2}{t} = 2y^{-1}$$

$$\frac{dx}{dt} = 2, \frac{dy}{dt} = -\frac{2}{t^2}$$

$$\frac{dy}{dx} = \frac{dy}{dt} \cdot \frac{dt}{dx} = -\frac{2}{t^2} \cdot \frac{1}{2} = -\frac{1}{t^2}$$

Gradient = $\frac{y - \frac{2}{t}}{x - 2t}$

But gradient = $-\frac{1}{t^2}$

$$\Rightarrow \frac{y - \frac{2}{t}}{x - 2t} = -\frac{1}{t^2}$$

$$t^2 \left(y - \frac{2}{t} \right) = -(x - 2t)$$

$$t^2 y + x - 4t = 0$$

- (b)(i) Find the equations of the tangents in (a), which are parallel to $y + 4x = 0$

$$t^2 y + x - 4t = 0$$

$$y = -\frac{1}{t^2}x + \frac{4}{t}$$

$$\text{gradient} = -\frac{1}{t^2}$$

For $y + 4x = 0$

$$y = -4x$$

gradient = -4

But parallel lines have equal gradient

$$-\frac{1}{t^2} = -4; t^2 = \frac{1}{4} \text{ and } t = \pm \frac{1}{2}$$

Substituting for $t = \frac{1}{2}$

$$y = -\frac{1}{\left(\frac{1}{2}\right)^2}x + \frac{4}{\left(\frac{1}{2}\right)}$$

$$y = -4x + 8$$

Substituting for $t = -\frac{1}{2}$

$$y = -\frac{1}{\left(-\frac{1}{2}\right)^2}x + \frac{4}{\left(-\frac{1}{2}\right)}$$

$$y = -4x - 8$$

- (ii) Determine the distance between the tangents in (i)

Solution

By the nature of the parametric points in the form $(2t, \frac{2}{t})$, this is a rectangular hyperbola

Substituting for $t = \pm \frac{1}{2}$, the points become (1, 4) and (-1, -4)

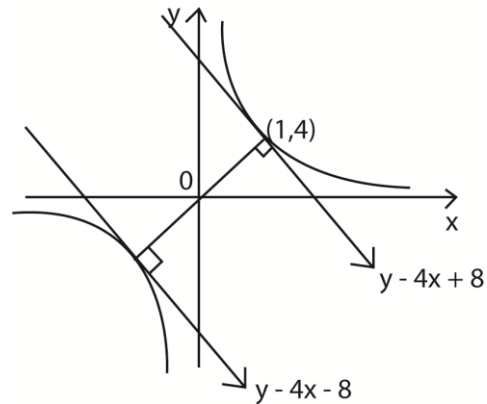

The distance between two tangents = perpendicular distance between them

$$\text{Using } d = \frac{|ax_1 + by_1 + c|}{\sqrt{a^2 + b^2}}$$

We use either $y = -4x + 8$

Considering $y = -4x + 8$ or $y + 4x - 8 = 0$;

$$a = 4, b = 1, c = -8$$

Substituting for $(x, y) = (-1, -4)$

$$d = \frac{|4(-1) + 1(-4) - 8|}{\sqrt{1^2 + 4^2}} = \frac{16}{\sqrt{17}} = 3.88$$

2. The tangents at the points $P(cp, c/p)$ and $Q(cq, c/q)$ on the rectangular hyperbola $xy = c^2$ intersect at R . Given that R lies on the curve $xy = \frac{c^2}{2}$; show that the locus of the mid-point of the PQ is given by $xy = 2c^2$. (12marks)

Solution

Gradient of tangent at P

$$x = cp \text{ and } y = c/p$$

$$\frac{dx}{dp} = c, \frac{dy}{dp} = -\frac{c}{p^2}$$

$$\frac{dy}{dx} p = \frac{dy}{dp} \cdot \frac{dp}{dx} = -\frac{c}{p^2} \cdot \frac{1}{c} = -\frac{1}{p^2}$$

Equation of the tangent at P

$$\frac{y - \frac{c}{p}}{x - cp} = -\frac{1}{p^2}$$

$$y - \frac{c}{p} = -\frac{1}{p^2}(x - cp)$$

$$x + p^2y - 2cp = 0 \dots\dots\dots(i)$$

Similarly equation of the tangent at Q is

$$x + q^2y - 2cq = 0 \dots\dots\dots(ii)$$

Eqn. (i) – eqn. (ii)

$$(p^2 - q^2)y = 2c(p - q)$$

$$y = \frac{2c(p-q)}{(p-q)(p+q)} = \frac{2c}{(p+q)}$$

Substituting for y into eqn. (ii)

$$x + q^2\left(\frac{2c}{(p+q)}\right) - 2cq = 0$$

$$x = \frac{2cpq}{(p+q)}$$

Hence R $\left(\frac{2cpq}{(p+q)}, \frac{2c}{(p+q)}\right)$

Since R lies on $xy = \frac{c^2}{2}$, substitute for the values of x and y

$$\frac{2cpq}{(p+q)} \cdot \frac{2c}{(p+q)} = \frac{c^2}{2}$$

$$\frac{(p+q)^2}{pq} = 8$$

Finding the midpoint of PQ

$$x = \frac{cp+cq}{2} = \frac{c(p+q)}{2}$$

$$y = \frac{\frac{c}{p} + \frac{c}{q}}{2} = \frac{c(p+q)}{2pq}$$

$$xy = \frac{c(p+q)}{2} \cdot \frac{c(p+q)}{2pq}$$

$$= \frac{c^2}{4} \cdot \frac{(p+q)}{pq}$$

$$= \frac{c^2}{4} \cdot 8$$

$$xy = 2c^2 \text{ (as required)}$$

3. The normal to the rectangular hyperbola $xy = 8$ at point $(4, 2)$ meets the asymptotes at M and N. find the length MN.

Solution

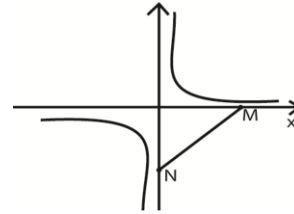

The equation of the normal to a rectangular hyperbola $xy = c^2$ at a point $(ct, \frac{c}{t})$ is given

$$\text{by } t^3x = ty + c(t^4 - 1)$$

Comparing $xy = c^2$ with $xy = 8$

$$\Rightarrow c^2 = 8; c = 2\sqrt{2}$$

Also comparing point $(ct, \frac{c}{t})$ with $(4, 2)$

$$\Rightarrow ct = 4$$

$$(2\sqrt{2})t = 4$$

$$t = \frac{4}{2\sqrt{2}} = \sqrt{2}$$

Find the equation of the normal by substituting for c and t.

$$(\sqrt{2})^3 = (\sqrt{2})y + 2\sqrt{2}[(\sqrt{2})^4 - 1]$$

$$(\sqrt{2})^2 = y + 2[(\sqrt{2})^4 - 1]$$

$$2x = y + 6$$

$$y = 2x - 6$$

The normal drawn from the curve meets the asymptotes at the x-axis (M) and y-axis N as shown above

At point, $y = 0$

$$\Rightarrow 2x = 6; x = 3, M(3, 0)$$

At point, $x = 0$

$$\Rightarrow y = -6; N(0, -6)$$

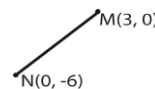

$$NM = \sqrt{(3 - 0)^2 + (0 - 6)^2} = 3\sqrt{5} = 6.708 \text{ units}$$

Alternatively

$$y + x \frac{dy}{dx} = 0$$

$$\frac{dy}{dx} = -\frac{y}{x}$$

At $(4, 2)$

$$\frac{dy}{dx} - \frac{2}{4} = -\frac{1}{2}$$

Hence gradient of normal at (4,2) is 2

Finding the equation of the normal

$$\frac{y-2}{x-4} = 2$$

$$y = 2x - 6$$

Along y-axis at N, $x = 0 \Rightarrow y = -6$, N(0, -6)

Along x-axis at M, $y = 0 \Rightarrow x = 3$, M(3, 0)

$$\begin{aligned} \overline{NM} &= \sqrt{(3-0)^2 + (0-(-6))^2} \\ &= 3\sqrt{5} = 6.708 \text{ units} \end{aligned}$$

Revision Exercise 6

1. Show that the line $y = mx + c$ is a tangent to the hyperbola $\frac{x^2}{a^2} - \frac{y^2}{b^2} = 1$ if $c = \sqrt{a^2m^2 - b^2}$

2. (a) Determine the equation of the tangent and normal at P(ct, c/t) on the rectangular hyperbola $xy = c^2$.

$$\left. \begin{array}{l} \text{Eqn. tangent: } x + t^2y = 2ct \\ \text{Eqn. normal: } ty + ct^4 = t^3x + c \end{array} \right\}$$

- (b) The normal at P meets the hyperbola again at Q(cT, c/T). Show that $t^3T + 1 = 0$

- (c) If the tangents at P and Q in (b) above meet at R, show that the locus of R is $(x^2 - y^2)^2 + 4c^2xy = 0$

3. A point A is the midpoint of PQ on the rectangular hyperbola $xy = c^2$ where P and Q are respectively (cp, c/p) and (cq, c/q). The line through P and Q meets the x-axis at B. The line through B parallel to OA meets the hyperbola at R(cr, c/r) and S(cs, c/s). Show that $rs + pq = 0$ and $r + s = p + q$.

4. (a) Part of the line $x - 3y + 3 = 0$ is a chord of rectangular hyperbola $x^2 - y^2 = 5$. Find the length of the chord. $\left[\frac{7\sqrt{10}}{4} \right]$

- (c) Find the equation of the tangent at the point P(ct, c/t) on the rectangular hyperbola $xy = c^2$ and prove that the equation of the normal at P is

$$y = t^2x + \frac{c}{t} - ct^3$$

$$[\text{Tangent: } x + t^2y = 2ct]$$

5. The tangent at any point P(ct, c/t) on hyperbola $xy = c^2$ meets x and y-axis at A and B respectively, O is the origin.

- (a) Prove that

(i) $AP = PB$

(ii) The area of triangle AOB is constant

- (b) If the hyperbola is rotated through an angle of -45° about O, find the new equation of the curve

$$[x^2 - y^2 = 2c^2]$$

6. (a) find the equation of the chord joining the points P(cp, c/p) and Q(cq, c/q)

$$[x + pqy = c(p + q)]$$

- (b) Find the equation of the tangent to the hyperbola $x = 4t$, $y = 4/t$ which passes through (4, 3)

$$[x + 4y = 16 \text{ and } 9x + 4y = 48]$$

7. P is a variable point given by parametric equations $x = \frac{a}{2} \left(t + \frac{1}{t} \right)$, $y = \frac{b}{2} \left(t + \frac{1}{t} \right)$. Show that the locus of P is $\frac{x^2}{a^2} - \frac{y^2}{b^2} = 1$.

State the asymptotes. Determine the coordinates of the point where the tangent from P meets the asymptotes. $[(a/t, -b/t)]$

8. Prove that $y = -3x + 6$ is a tangent to a rectangular hyperbola whose parametric coordinates are of the form $\left[\sqrt{3}t, \frac{\sqrt{3}}{t} \right]$

9. (a) Show that the equation of the tangent to the hyperbola (asec θ , btan θ) is $bx - aysin\theta - abc\cos\theta$

- (b) Find the equation of the tangents to $\frac{x^2}{4} - \frac{y^2}{9} = 1$, at the points where $\theta = 45^\circ$ and where $\theta = -135^\circ$.

$$\left[y = \frac{3\sqrt{2}}{2}x - 3, y = \frac{3\sqrt{2}}{2}x + 3 \right]$$

(c) Find the asymptotes

$$\left[y = \pm \frac{3}{2}x \right]$$

Thank you
Dr. Bbosa Science