



Dr. Bhasa Science

Sponsored by
The Science Foundation College
Uganda East Africa
Senior one to senior six

+256 778 633682 0753 143413

Based on, Best for Science

digitalteachers.co.ug



Nuture your dreams

SENIOR SIX TERM 3

TOPIC 1/3: Complex Number

Competency: The learner applies concepts of complex numbers to solve modelling problems across different mathematical and real-world scenarios.

Complex numbers

Equations $ax^2 + bx + c = 0$ where $a \neq 0$ and $b^2 < 4ac$ can only be solved by introducing $\sqrt{-1}$ = i or j ; and this is the basis of complex numbers.

Solving equations involving complex numbers

Given $ax^2 + bx + c = 0$

$$x^2 + \left(\frac{b}{a}\right)x = \left(-\frac{c}{a}\right)$$

$$\left(x + \frac{b}{2a}\right)^2 = \left(\frac{b^2}{4a^2} - \frac{c}{a}\right) = \frac{b^2 - 4ac}{4a^2}$$

$$x + \frac{b}{2a} = \pm \sqrt{\frac{b^2 - 4ac}{4a^2}}$$

$$x = -\frac{b}{2a} \pm \sqrt{\frac{b^2 - 4ac}{4a^2}}$$

$$x = -\frac{b}{2a} \pm \frac{\sqrt{b^2 - 4ac}}{2a}$$

If $b^2 > 4ac$; the equation has two roots which are both real.

If $b^2 = 4ac$; the equation has got two roots which are repeated and real.

If $b^2 < 4ac$; the equation has got two roots which are not real.

In complex numbers equations whose roots are not real are considered

Hence

$$x = -\frac{b}{2a} \pm i \frac{\sqrt{b^2 - 4ac}}{2a}$$

We let $x = p \pm iq$

$$\text{Where } p = -\frac{b}{2a} \text{ and } q = \frac{\sqrt{b^2 - 4ac}}{2a}$$

Example 1

(a) $x^2 + 4 = 0$

Solution

$$x^2 = -4$$

$$x = \sqrt{-4} = \pm 2i$$

(b) $x^2 + 2x + 5 = 0$

Solution

$$\text{From } x = \frac{-b \pm \sqrt{b^2 - 4ac}}{2a}$$

$$x = \frac{-2 \pm \sqrt{4 - 4(1)(5)}}{2(1)} = \frac{-2 \pm \sqrt{-16}}{2} = \frac{-2 \pm 4i}{2}$$

$$x = -1 \pm 2i$$

(c) $2x^2 - 3x + 4 = 0$

$$x = \frac{3 \pm \sqrt{9 - 4(2)(4)}}{2(2)} = \frac{3 \pm \sqrt{-25}}{4} = \frac{3 \pm 5i}{4}$$

$$x = \frac{3}{4} \pm \frac{5}{4}i$$

The above simple examples reveal the following

- (a) A complex number Z may be written as $Z = x + iy$, where x and y are real numbers. The real part of Z is x and the imaginary part is y . i.e. $x = \text{Re}(Z)$ and $y = \text{Im}(Z)$.
- (b) Solution of such equations whose roots are complex occur in pairs, called conjugates. For instance, compare $Z = \pm 2i, -1 \pm 2i$ and $\frac{3}{4} \pm \frac{5}{4}i$

(i) If $Z = -1 + 2i$ is one root of an equation, then its conjugate $\bar{Z} = -1 - 2i$ is another root.

(ii) An equation cannot have odd number of complex roots

(c) If $x + iy = 0$, then $x = 0$ and $y = 0$

This implies that two complex numbers are equal if and only if their corresponding real and imaginary parts are equal

i.e. $Z_1 = x_1 + iy_1$ and $Z_2 = x_2 + iy_2$, then $Z_1 = Z_2$, only and only if $x_1 = x_2$ and $y_1 = y_2$.

Proof: If $Z_1 = Z_2$

$$x_1 + iy_1 = x_2 + iy_2$$

$$\text{i.e. } (x_1 - x_2) + (y_1 - y_2)i = 0$$

$$\Rightarrow x_1 - x_2 = 0 \text{ and } y_1 - y_2 = 0$$

$$x_1 = x_2 \text{ and } y_1 = y_2$$

Algebra of complex numbers

Like in the real plane, complex numbers can be subjected to four basic operations of addition, subtraction, multiplications and division.

Using $Z_1 = x_1 + iy_1$ and $Z_2 = x_2 + iy_2$

Addition of complex number

When adding two or more complex numbers, real parts are added separately and imaginary parts are added separately

$$Z_1 + Z_2 = (x_1 + x_2) + i(y_1 + y_2)$$

Illustration

$$\text{If } Z_1 = 2 + 3i \text{ and } Z_2 = 1 - 2i$$

$$Z_1 + Z_2 = (2 + 1) + i(3 - 2)$$

$$= 3 + 1i$$

Subtraction of complex numbers

When subtracting two or more complex numbers, real parts are subtracted from real

parts and imaginary parts subtracted from imaginary parts.

$$Z_1 - Z_2 = (x_1 - x_2) + i(y_1 - y_2)$$

Illustration

$$\text{If } Z_1 = 2 + 3i \text{ and } Z_2 = 1 - 2i$$

$$Z_1 - Z_2 = (2 - 1) + i(3 - (-2))$$

$$= 1 + 5i$$

Geometrically, the operations of addition and subtraction of complex numbers are diagonals of a parallelogram. (see the Argand diagrams)

Multiplication of complex numbers

When multiplying complex numbers the following properties should be observed

$$i^2 = \sqrt{-1} \times \sqrt{-1} = -1 ;$$

$$i^3 = -1 \times i = -i$$

$$i^4 = i^2 \times i^2 = -1 \times -1 = 1$$

$$i^5 = i^3 \times i^2 = -1 \times -1 = 1$$

$$i^6 = i^3 \times i^3 = -1 \times -1 = 1$$

$$i^8 = i^4 \times i^4 = 1 \times 1 = 1$$

Now

$$\begin{aligned} Z_1 Z_2 &= (x_1 + iy_1)(x_2 + iy_2) \\ &= x_1 x_2 + ix_1 y_2 + ix_2 y_1 + i^2 y_1 y_2 \\ &= (x_1 x_2 - y_1 y_2) + i(x_1 y_2 + x_2 y_1) \end{aligned}$$

Division of complex numbers

When dividing a complex number with another, the result is also a complex number. It can be done in two ways

Either:

Let $\frac{Z_1}{Z_2} = p + iq$ for some real numbers p and q .

$$\Rightarrow Z_1 = (p + iq)Z_2$$

$$\begin{aligned} x_1 + iy_1 &= (p + iq)(x_2 + iy_2) \\ &= px_2 + ipy_2 + iqx_2 + i^2 qy_2 \\ &= px_2 - qy_2 + i(py_2 + qx_2) \end{aligned}$$

Equating the corresponding real and imaginary parts of the resulting complex number

$$x_1 = px_2 - qy_2 \text{ and } y_1 = py_2 + qx_2$$

Solving these equations simultaneously for p and q

$$p = \frac{x_1 x_2 + y_1 y_2}{x_2^2 + y_2^2} \text{ and } q = \frac{x_1 x_2 - y_1 y_2}{x_2^2 + y_2^2}$$

Or:

'Realizing' the denominator by multiplying through by its conjugate

$$\begin{aligned} \frac{Z_1}{Z_2} &= \frac{(x_1 + iy_1)(x_2 - iy_2)}{(x_2 + iy_2)(x_2 - iy_2)} = \frac{x_1 x_2 - ix_1 y_2 - ix_2 y_1 + y_1 y_2}{x_2^2 + y_2^2} \\ &= \frac{x_1 x_2 + y_1 y_2}{x_2^2 + y_2^2} + i \frac{(x_1 x_2 - y_1 y_2)}{x_2^2 + y_2^2} \end{aligned}$$

Example 2

Given that $Z_1 = 3 - 2i$ and $Z_2 = 2 + 3i$, by expressing your answer in the form $a + bi$, find

(a) $Z_1 + Z_2$

Solution

$$Z_1 + Z_2 = (3 - 2i) + (2 + 3i) = 5 + i$$

(b) $2Z_1 - Z_2$

Solution

$$2(3 - 2i) - (2 + 3i) = 4 - 7i$$

(c) If $Z_1 = 2 - 3i$ and $Z_2 = 4 + i$, find the values of

(i) $Z_1^3 Z_2$

Solution

$$Z_1^3 Z_2 = (2 - 3i)^3 (4 + i)$$

Using Pascal's triangle

$$= [2^3 + 3(2)^2(-3i) + 3(2)(-3i)^2 + (-3i)^3](4 + i)$$

$$= (8 - 36i - 54 + 27i)(4 + i)$$

$$= (-46 - 9i)(4 + i)$$

$$= -184 - 46i - 36i + 9$$

$$= -175 - 82i$$

(ii) $\frac{Z_2^1}{Z_1}$

Solutions

$$\frac{Z_2^1}{Z_1} = \frac{(4+i)^2}{(2-3i)} = \frac{16+8i-1}{(2-3i)} = \frac{15+8i}{(2-3i)}$$

$$= \frac{(15+8i)(2+3i)}{(2-3i)(2+3i)} = \frac{30+45i+16i-24}{4+9}$$

$$= \frac{6}{13} + i \frac{61}{13}$$

Forming quadratic equations given roots

When given roots to a complex number, the quadratic equation say Z can be obtained by finding the sum and the products of the roots

i.e. the equation is given by $Z^2 - (\text{sum of roots})Z + \text{product of roots}$

Not that if Z is a root of the equation, then its conjugate \bar{Z} is also a root

Example 3

Form a quadratic equation in Z given the following roots

(a) $1 + 5i$

Solution

Let $Z = 1 + 5i$, the $Z^* = 1 - 5i$

Sum of roots $(1 + 5i) + (1 - 5i) = 2$

Product of roots $(1 + 5i)(1 - 5i) = 26$

Equation: $Z^2 - 2Z + 26 = 0$

Or

Let $Z = 1 + 5i \Rightarrow Z - 1 - 5i = 0$

$Z = 1 - 5i \Rightarrow Z - 1 + 5i = 0$

$\Rightarrow (Z - 1 - 5i)(Z - 1 + 5i) = 0$

$Z^2 - 2Z + 26 = 0$

(b) $4 - 3i$

Solution

Let $Z = 4 - 3i$, the $Z^* = 4 + 3i$

Sum of roots $(4 - 3i) + (4 + 3i) = 8$

Product of roots $(4 - 3i)(4 + 3i) = 41$

Equation: $Z^2 - 8Z + 41 = 0$

Or

Let $Z = 4 - 3i \Rightarrow Z - 4 + 3i = 0$

$Z = 4 + 3i \Rightarrow Z - 4 - 3i = 0$

$\Rightarrow (Z - 4 + 3i)(Z - 4 - 3i) = 0$

$Z^2 - 8Z + 41 = 0$

Solving cubic equations

It is quite difficult to solve cubic equations, however, we use the approach of inspection, i.e. we substitute the assumed factors into the given equation. If the function is $f(x) = 0$ and $x - a = 0$ is a root, then $f(a) = 0$.

We then get another equation (quadratic) using long division which can easily be solved to obtain other factors.

Example 4

Solve the following equations

(a) $x^3 - 4x^2 + x + 26 = 0$

Solution

Let $f(x) = x^3 - 4x^2 + x + 26 = 0$

$f(1) = 2 - 4 + 1 + 26 \neq 0$; $\Rightarrow x - 1$ is not a factor

$f(2) = 8 - 8 + 2 + 26 \neq 0$; $\Rightarrow x - 2$ is not a factor

$f(-2) = -8 - 16 - 2 + 26 = 0$; $x + 2$ is a factor

Using long division

$$\begin{array}{r}
 x^2 - 6x + 13 \\
 (x + 2) \overline{) x^3 - 4x^2 + x + 26} \\
 \underline{- x^3 + 2x^2} \\
 - 6x^2 + x + 26 \\
 \underline{- -6x^2 - 12x} \\
 13x + 26 \\
 \underline{- 13x + 26} \\
 0 + 0
 \end{array}$$

$\therefore x^3 - 4x^2 + x + 26 = (x + 2)(x^2 - 6x + 13) = 0$

Either $x + 2 = 0$; $x = -2$

Or $x^2 - 6x + 13 = 0$

Solving $x^2 - 6x + 13 = 0$

$$x = \frac{6 \pm \sqrt{36 - 4(1)(13)}}{2(1)} = \frac{6 \pm \sqrt{16x - 1}}{2} = 3 \pm 2i$$

The roots of the equation are $x = -2, 3 \pm 2i$

Alternatively

Given the equation $x^2 - 6x + 13 = 0$

Let the roots be $x \pm 2i$

Sum of roots $x + iy + x - iy = 6$

$$2x = 6; x = 3$$

Product of roots $(x + iy)(x - iy) = 13$

$$x^2 + y^2 = 13$$

Substituting for x ;

$$9 + y^2 = 13; y = \pm 2$$

The roots of the equation are $x = -2, 3 \pm 2i$

(b) $2x^3 - 12x^2 + 25x - 21 = 0$

Solution

Let $f(x) = 2x^3 - 12x^2 + 25x - 21 = 0$

$f(1) = 2 - 12 + 25 - 21 = -6 \neq 0$; $x - 1$ is not a factor

$f(2) = 16 - 48 + 50 - 21 = -3 \neq 0$; $x - 2$ is not a factor

$f(3) = 54 - 108 + 75 - 21 = 0$; $x - 3$ is a factor

Using long division

$$\begin{array}{r}
 2x^2 - 6x + 7 \\
 (x - 3) \overline{) 2x^3 - 12x^2 + 25x - 21} \\
 \underline{- 2x^2 - 6x^2} \\
 -6x^2 + 25x - 21 \\
 \underline{- -6x^2 + 18x} \\
 7x - 21 \\
 \underline{- 7x - 21} \\
 0 + 0
 \end{array}$$

$\therefore 2x^3 - 12x^2 + 25x - 21$

$= (x-3)(2x^2 - 6x + 7) = 0$

Either $x - 3 = 0$; $x = 3$

Or $2x^2 - 6x + 7 = 0$

$x = \frac{6 \pm \sqrt{36 - 4(2)(7)}}{2(2)} = \frac{6 \pm \sqrt{4 \times 5 \times -1}}{4} = \frac{3}{2} \pm \frac{\sqrt{5}}{2}$

The roots of the equation are $x = 3, \frac{3}{2} \pm \frac{\sqrt{5}}{2}$

Alternatively

Given the equation $2x^2 - 6x + 7 = 0$

Or $x^2 - 3 + \frac{7}{2} = 0$

Let the roots be $x \pm 2i$

Sum of roots $x + iy + x - iy = 3$

$2x = 3$; $x = \frac{3}{2}$

Product of roots $= (x + iy)(x - iy) = \frac{7}{2}$

$x^2 + y^2 = \frac{7}{2}$

Substituting for x ;

$\frac{9}{4} + y^2 = \frac{7}{2}$; $y = \frac{\pm\sqrt{5}}{2}$

The roots of the equation are $x = 3, \frac{3}{2} \pm \frac{\sqrt{5}}{2}$

Finding the square root of a complex number

Suppose that the square root of Z is $a + bi$

Then $a + bi = Z^{\frac{1}{2}} \Rightarrow (a + bi)^2 = Z$

Example 5

Find the square roots of

(a) $-5 + 12i$

Solution

Approach 1

Let $\sqrt{-5 + 12i} = x + iy$

By squaring both sides

$-5 + 12i = x^2 - y^2 + i2xy$

Equating corresponding parts

$x^2 - y^2 = -5$ (i)

$2xy = 12$

$x = \frac{6}{y}$ (ii)

Substituting eqn.(ii) into eqn. (i)

$(\frac{6}{y})^2 - y^2 = -5$

$$36 - y^4 = -5y^2$$

Let $k = y^2$

$$k^2 - 5k - 36 = 0$$

$$(k - 9)(k + 4) = 0 \text{ i.e. } k = 9 \text{ or } k = -4$$

When $k = -4$, $y^2 = -4$ which is inadmissible since y must be real.

$$\text{When } k = 9; y^2 = 9 \Rightarrow y = \pm 3$$

$$\Rightarrow x = \frac{6}{\pm 3} = \pm 2$$

$$\therefore \sqrt{(-5 + 12i)} = 2 + 3i \text{ or } -2 - 3i \equiv \pm(2 + 3i)$$

Approach 2

$$\text{Let } \sqrt{(-5 + 12i)} = x + iy$$

$$x^2 - y^2 + i2xy = -5 + 12i$$

Equating corresponding parts

$$x^2 - y^2 = -5 \dots\dots\dots (i)$$

$$2xy = 12 \dots\dots\dots (ii)$$

$$\text{Eqn. (i)}^2 + \text{eqn. (ii)}^2$$

$$x^4 - 2x^2y^2 + y^4 = 25$$

$$+ \quad 4x^2y^2 = 144$$

$$\hline x^4 + 2x^2y^2 + y^4 = 169$$

$$(x^2 + y^2)^2 = 169$$

$$x^2 + y^2 = 13 \dots\dots\dots (iii)$$

$$\text{Eqn. (i)} + \text{eqn. (iii)}$$

$$2x^2 = 8; x = \pm 2$$

Substituting for x in eqn. (iii)

$$4 + y^2 = 13; y = \pm 3$$

$$\therefore \sqrt{(-5 + 12i)} = 2 + 3i \text{ or } -2 - 3i \equiv \pm(2 + 3i)$$

$$(b) \quad 3 + 4i$$

$$\text{Let } \sqrt{(3 + 4i)} = x + iy$$

$$x^2 - y^2 + i2xy = 3 + 4i$$

Equating corresponding parts

$$x^2 - y^2 = 3 \dots\dots\dots (i) \text{ and } 2xy = 4 \dots\dots\dots (ii)$$

$$\text{Eqn. (i)}^2 + \text{eqn. (ii)}^2$$

$$x^4 - 2x^2y^2 + y^4 = 9$$

$$+ \quad 4x^2y^2 = 16$$

$$\hline x^4 + 2x^2y^2 + y^4 = 25$$

$$(x^2 + y^2)^2 = 25$$

$$x^2 + y^2 = 5 \dots\dots\dots (iii)$$

$$\text{Eqn. (i)} + \text{eqn. (iii)}$$

$$2x^2 = 8; x = \pm 2$$

Substituting for x in eqn. (iii)

$$4 + y^2 = 5; y = \pm 1$$

$$\therefore \sqrt{(3 + 4i)} = 2 + i \text{ or } -2 - i \equiv \pm(2 + i)$$

Other equations

Example 6

Solve the simultaneous equations

$$Z_1 + Z_2 = 8$$

$$4Z_1 - 3iZ_2 = 26 + 8i$$

Solution

$$Z_1 + Z_2 = 8$$

$$Z_1 = 8 - Z_2 \dots\dots\dots (i)$$

$$4Z_1 - 3iZ_2 = 26 + 8i \dots\dots\dots (ii)$$

Substituting eqn. (i) into eqn. (ii)

$$4(8 - Z_2) + 3iZ_2 = 26 + 8i$$

$$32 - 4Z_2 - 3iZ_2 = 26 + 8i$$

$$(4 + 3i)Z_2 = 6 - 8i$$

$$Z_2 = \frac{(6-8i)(4-3i)}{(4+3i)(4-3i)} = \frac{-50i}{25} = -2i$$

Substituting for Z_2 into (i)

$$Z_1 = 8 + 2i$$

$$\therefore Z_1 = 8 + 2i \text{ and } Z_2 = -2i$$

Example 7

Solve the equation $6x^2 - 2(1 + 2i)x - 1 = 0$

Solution

$$\text{Using } x = \frac{-b \pm \sqrt{b^2 - 4ac}}{2a}$$

$$x = \frac{2(1 + 2i) \pm \sqrt{4(1 + 2i)^2 - 4(6)(-1)}}{2(6)}$$
$$= \frac{1 + 2i \pm \sqrt{3 + 4i}}{6}$$

$$\text{But } \sqrt{3 + 4i} = \pm(2 + i)$$

$$\Rightarrow x = \frac{1 + 2i \pm (2 + i)}{6}$$

Revision exercise 1

1. Simplify each of the following and express your answer in the form $a + bi$

(a) $(3 + 4i) + (2 + 3i) [5 + 7i]$

(b) $(3 + 4i) - (2 - 3i) [1 + 7i]$

(c) $(2i)^2 [-4]$

(d) $(2 + 3i)(2 - 3i) [13]$

(e) $(3 + 4i)(1 - 2i) [11 - 2i]$

2. If Z is a complex number in form $(a + bi)$ solve

(a) $\left(\frac{Z-1}{Z+1}\right)^2 = i$ [$Z = (1 \pm \sqrt{2})i$]

(b) $\frac{Z}{Z+1} = 1 + 2i$ [$-1 + \frac{1}{2}i$]

(c) Express each of the following complex numbers in the form $a + bi$

(a) $Z_1 = (1 - i)(1 + 2i) [3 + i]$

(b) $Z_2 = \frac{2+6i}{3-i} [2i]$

(c) $Z_3 = \frac{-4i}{1-i} [2 - 2i]$

(d) Find the square root of

(a) $12i - 5 [2 + 3i \text{ or } -2 - 3i]$

(b) $5 + 2i [\pm(3 + 2i)]$

(c) $15 + 8i [\pm(4 + i)]$

(d) $7 - 24i [\pm(4 - 3i)]$

$$\text{Either } x = \frac{1}{2} + \frac{1}{2}i \text{ or } x = -\frac{1}{6} + \frac{1}{6}i$$

Example 8

Solve the equation $\left(\frac{Z-1}{Z+1}\right)^2 = i$, if Z is a complex number in form $a + bi$

Solution

$$(Z - 1)^2 = i(Z + 1)^2$$

$$Z^2 - 2Z + 1 = iZ^2 + 2iZ + i$$

$$(i - 1)Z^2 + 2(i + 1)Z + i = 0$$

$$\Rightarrow Z^2 - 2iZ + 1 = 0$$

$$Z = \frac{2i \pm \sqrt{-4 - 4}}{2} = \frac{2i \pm 2i\sqrt{2}}{2} = i \pm \sqrt{2}$$

$$\therefore Z = (1 \pm \sqrt{2})i$$

(e) Given that $Z = 3 + 4i$, find the value of the expression $Z + \frac{25}{Z} [6]$

(f) Given that the complex number Z^* and its complex conjugate satisfy the equation $ZZ^* + 2iZ = 12 + 6i$, find the possible values of Z [$3 + 3i; 3 - i$]

(g) Solve the simultaneous equation

$$Z_1 + Z_2 = 8$$

$$4Z_1 - 3iZ_2 = 26 + 8i$$

$$[Z_1 = 8 + 2i \text{ and } Z_2 = -2i]$$

(h) Express each of the following in the form $a + bi$

(a) $\frac{2+3i}{1-i} \left[-\frac{1}{2} + \frac{5}{2}i\right]$

(b) $\frac{3-i}{1+2i} \left[\frac{1}{5} - \frac{7}{5}i\right]$

(c) $\frac{4}{1+i} [-1 + i]$

(d) $\frac{3+4i}{3-4i} - \frac{3-4i}{4+4i} \left[\frac{48i}{25}\right]$

(i) Solve the following equations

(a) $2x^2 + 32 = 0$ [$\pm 4i$]

(b) $4x^2 + 9 = 0 \left[\pm \frac{3}{2}i \right]$

(c) $x^2 + 2x + 5 = 0 \left[-1 \pm 2i \right]$

(d) $x^2 - 4x + 5 = 0 \left[2 \pm i \right]$

(e) $2x^2 + x + 1 = 0 \left[\frac{-1 \pm \sqrt{71}}{4} \right]$

(j) Form quadratic equations having roots

(a) $3i, -3i \left[x^2 + 9 = 0 \right]$

(b) $1 + 2i, 1 - 2i \left[x^2 - 2x + 5 = 0 \right]$

(c) $2 + i, 2 - i \left[x^2 - 4x + 5 = 0 \right]$

(d) $3 + 4i, 3 - 4i \left[x^2 - 6x + 25 = 0 \right]$

(k) Solve the following equations if each has at least one real root

(a) $x^3 - 7x^2 + 19x - 13 = 0 \left[1, 3 \pm 2i \right]$

(b) $2x^3 - 2x^2 - 3x - 2 = 0 \left[2, -\frac{1}{2} \pm \frac{1}{2}i \right]$

(c) $x^3 + 3x^2 + 5x + 3 = 0 \left[-1, \pm\sqrt{2}i \right]$

The Argand diagram

Complex numbers can be represented graphically just as coordinates are. However, instead of the x – axis and the y – axes, the real (Re) and the imaginary (Im) axes are used respectively instead. This representation was first suggested by a mathematician named R. Argand, hence the Argand diagram. Each complex number is represented by a line of certain length in a particular direction. Thus each complex number is shown as a vector on Argand diagram.

The sum and the difference of the two complex numbers can be shown on an Argand diagram in the same way as we show vectors which are normally added or subtracted.

The complex number $x + iy$ is represented as shown below

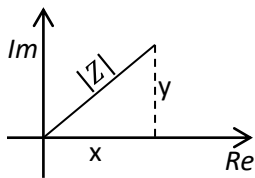

Example 8

Given $Z_1 = -1 + 2i$ and $Z_2 = 3 - i$ show $Z_1 + Z_2$ and $Z_2 - Z_1$ using Argand diagram

(a) $Z_1 + Z_2 = -1 + 2i + 3 - i = 2 + i$

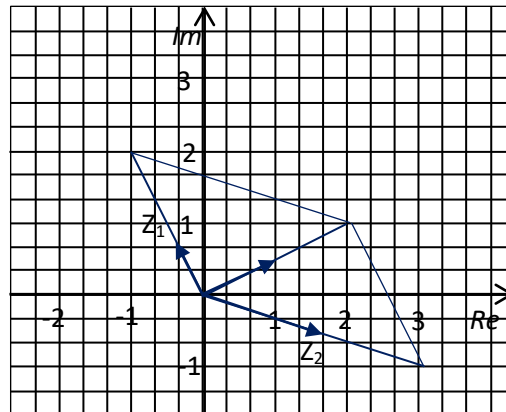

(b) $Z_2 - Z_1 = (3 - i) - (-1 + 2i) = 4 - 3i$

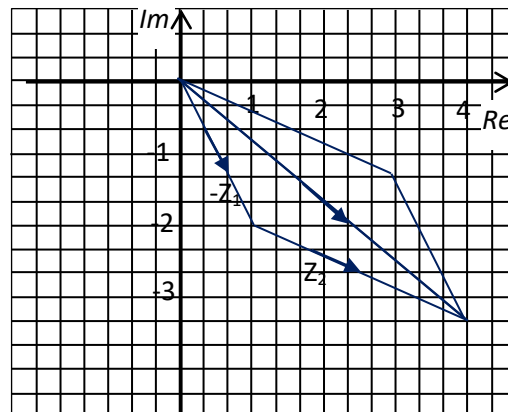

The modulus and argument of a complex number

From the above diagram

$$r^2 = |Z|^2 = x^2 + y^2$$

i.e. $r = |Z| = \sqrt{x^2 + y^2}$ which is modulus $Z = \text{mod}(Z)$ and $\tan\theta = \frac{y}{x}$, i.e. $\theta = \tan^{-1}\frac{y}{x}$, which is the argument, $\text{arg}(Z)$ or amplitude, $\text{amp}(Z)$.

Note: for principal values, $-\pi \leq \text{Arg}(Z) \leq \pi$

Example 9

Find the modulus and argument of the following

(a) $Z_1 = 1 + i$

Solution

$$|Z_1| = \sqrt{(1^2 + 1^2)} = \sqrt{2}$$

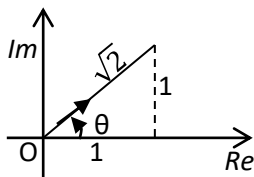

$$\text{Arg}(Z_1) = \tan^{-1}\left(\frac{1}{1}\right) = 45^\circ \text{ or } \frac{\pi}{4}$$

(b) $Z_2 = 1 - i$

Solution

$$|Z_1| = \sqrt{(1^2 + (-1)^2)} = \sqrt{2}$$

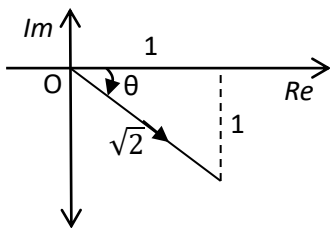

$$\text{Arg}(Z_2) = \tan^{-1}(-1) = 45^\circ \text{ or } -\frac{\pi}{4}$$

(c) $Z_3 = -3 + 4i$

Solution

$$|Z_2| = \sqrt{((-3)^2 + 4^2)} = 5$$

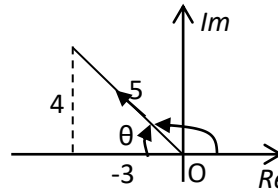

$$\text{Arg}(Z_3) = \tan^{-1}\left(\frac{4}{-3}\right) = 180^\circ - 53.1^\circ = 126.9^\circ$$

Note: Due care must be taken in obtaining the argument of complex numbers as above example shows. Although the moduli for Z_1 and Z_2 are the same, the arguments differ because they fall in different quadrants. A sketch may be thus necessary pre-requisite.

The polar (modulus – argument) form of a complex number.

Given $Z = x + iy$ (the Cartesian form)

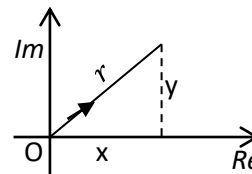

$$x = r\cos\theta \text{ and } y = r\sin\theta$$

$$\therefore Z = x + iy = r\cos\theta + r\sin\theta$$

i.e. $Z = r\cos\theta + r\sin\theta$ or simply $Z = r\text{cis}$. This form is referred to as polar form of Z .

Example 10

Express $Z_1 = -1 - i$ and $Z_2 = -\sqrt{3} + 3i$

Solution

$$(a) |Z_1| = \sqrt{((-1)^2 + (-1)^2)} = \sqrt{2}$$

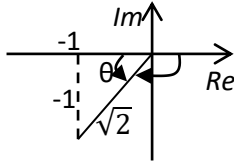

$$\text{Arg}(Z_1) = \tan^{-1}\left(\frac{-1}{-1}\right) = 225^\circ = -135^\circ \text{ or } -\frac{\pi}{4}$$

$$\begin{aligned} Z_1 &= \sqrt{2}(\cos(-135^\circ) + i\sin(-135^\circ)) \\ &= \sqrt{2}\left(\cos\frac{3\pi}{4} - i\sin\frac{3\pi}{4}\right) \end{aligned}$$

$$(b) |Z_2| = \sqrt{((-\sqrt{3})^2 + 3^2)} = 2\sqrt{3}$$

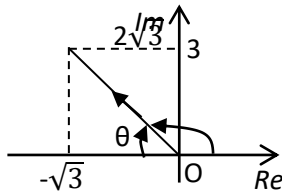

$$\text{Arg}(Z_2) = \tan^{-1}\left(\frac{3}{-\sqrt{3}}\right) = 120^\circ = \frac{2\pi}{3}$$

$$Z_2 = 2\sqrt{3}(\cos 120^\circ + i\sin 120^\circ)$$

$$Z_2 = 2\sqrt{3}\left(\cos\frac{2\pi}{3} + i\sin\frac{2\pi}{3}\right)$$

Multiplication and division of polar form

The two operations offer valuable results in complex plane

Let $|Z_1| = r_1$ and $\text{arg}(Z_1) = \theta_1$ i.e.

$$|Z_1| = r_1(\cos\theta_1 + i\sin\theta_1)$$

Let $|Z_2| = r_2$ and $\text{arg}(Z_2) = \theta_2$ i.e.

$$|Z_2| = r_2(\cos\theta_2 + i\sin\theta_2)$$

(a) Multiplication of polar form

Please find free notes, tests and marking guides of physics, chemistry, biology and mathematics from: digitalteachers.co.ug

$$\begin{aligned} Z_1 Z_2 &= r_1 r_2 (\cos\theta_1 + i\sin\theta_1)(\cos\theta_2 + i\sin\theta_2) \\ &= r_1 r_2 (\cos\theta_1 \cos\theta_2 + i \cos\theta_1 \sin\theta_2 + i \sin\theta_1 \cos\theta_2 - \sin\theta_1 \sin\theta_2) \end{aligned}$$

$$= r_1 r_2 \{(\cos\theta_1 \cos\theta_2 - \sin\theta_1 \sin\theta_2) + i(\cos\theta_1 \sin\theta_2 + \sin\theta_1 \cos\theta_2)\}$$

$$= r_1 r_2 \{\cos(\theta_1 + \theta_2) + i\sin(\theta_1 + \theta_2)\}$$

Deductions:

$$(i) |Z_1 Z_2| = r_1 r_2 = |Z_1| |Z_2|$$

$$(ii) \text{arg}(Z_1 Z_2) = \theta_1 + \theta_2 = \text{arg}(Z_1) + \text{arg}(Z_2)$$

$$(iii) |Z^2| = |Z| |Z| = |Z|^2$$

$$(iv) \text{arg}(Z^2) = \text{arg}(Z) + \text{arg}(Z) = 2 \text{arg}(Z)$$

In general

$$(i) |Z_1 Z_2 Z_3 \dots Z_n| = |Z_1| |Z_2| |Z_3| \dots |Z_n|$$

$$(ii) |Z^n| = |Z| |Z| |Z| \dots |Z| = |Z|^n$$

$$(iii) \text{arg}(Z_1 Z_2 Z_3 \dots Z_n)$$

$$= \text{arg}(Z_1) + \text{arg}(Z_2) + \text{arg}(Z_3) \dots \text{arg}(Z_n)$$

$$(iv) \text{arg}(Z^n) = n \text{arg}(Z)$$

Example 11

Given that $Z_1 = 3 + 4i$ and $Z_2 = 1 - i$, find

$$(i) |Z_1 Z_2|$$

$$(ii) \text{Arg}(Z_1 Z_2)$$

Solution

$$|Z_1| = \sqrt{3^2 + 4^2} = 5$$

$$\text{arg}(Z_1) = \tan^{-1}\left(\frac{4}{3}\right) = 53.1^\circ$$

$$|Z_2| = \sqrt{1^2 + (-1)^2} = \sqrt{2}$$

$$\text{arg}(Z_2) = \tan^{-1}\left(-\frac{1}{1}\right) = -45^\circ$$

$$(i) |Z_1 Z_2| = |Z_1| |Z_2| = 5\sqrt{2}$$

$$(ii) \text{arg}(Z_1 Z_2) = \theta_1 + \theta_2 = 53.1^\circ + (-45^\circ) = 8.1^\circ$$

Example 12

Given that $Z_1 = 3(\cos\frac{\pi}{3} + i\sin\frac{\pi}{3})$

And $Z_2 = 5(\cos\frac{\pi}{4} + i\sin\frac{\pi}{4})$ find

- (i) $|Z_1 Z_2|$
- (ii) $Arg(Z_1 Z_2)$

Solution

For

$$Z_1 = 3(\cos\frac{\pi}{3} + i\sin\frac{\pi}{3}); |Z_1| = 3 \text{ and } arg(Z_1) = \frac{\pi}{3}$$

For

$$Z_2 = 5(\cos\frac{\pi}{4} + i\sin\frac{\pi}{4}); |Z_2| = 5 \text{ and } arg(Z_2) = \frac{\pi}{4}$$

- (i) $|Z_1 Z_2| = |Z_1| |Z_2| = 3 \times 5 = 15$
- (ii) $arg(Z_1 Z_2) = \theta_1 + \theta_2 = \frac{\pi}{3} + \frac{\pi}{4} = \frac{7\pi}{12}$

(b) Division of polar form

$$\frac{Z_1}{Z_2} = \frac{r_1}{r_2} \left\{ \frac{\cos\theta_1 \cos\theta_2 - i\cos\theta_1 \sin\theta_2 + i\sin\theta_1 \cos\theta_2 - \sin\theta_1 \sin\theta_2}{(\cos^2\theta_2 + \sin^2\theta_2)} \right\}$$

$$= \frac{r_1}{r_2} \{ \cos\theta_1 \cos\theta_2 - i\cos\theta_1 \sin\theta_2 + i\sin\theta_1 \cos\theta_2 - \sin\theta_1 \sin\theta_2 \}$$

$$= \frac{r_1}{r_2} \{ \cos(\theta_1 + \theta_2) + i\sin(\theta_1 + \theta_2) \}$$

Deduction

$$(a) \frac{Z_1}{Z_2} = \frac{r_1}{r_2} \frac{|Z_1|}{|Z_2|}$$

$$(b) arg\left(\frac{Z_1}{Z_2}\right) = \theta_1 - \theta_2 \\ = arg(Z_1) - arg(Z_2)$$

Example 13

Given that $Z_1 = 3 + 4i$ and $Z_2 = 1 - i$, find

- (i) $\left|\frac{Z_1}{Z_2}\right|$
- (ii) $Arg\left(\frac{Z_1}{Z_2}\right)$

Solution

$$|Z_1| = \sqrt{3^2 + 4^2} = 5$$

$$arg(Z_1) = \tan^{-1}\left(\frac{4}{3}\right) = 53.1^\circ$$

$$|Z_2| = \sqrt{1^2 + (-1)^2} = \sqrt{2}$$

$$arg(Z_2) = \tan^{-1}\left(-\frac{1}{1}\right) = -45^\circ$$

$$(i) \left|\frac{Z_1}{Z_2}\right| = \frac{|Z_1|}{|Z_2|} = \frac{5}{\sqrt{2}} = \frac{5\sqrt{2}}{2}$$

$$(ii) arg\left(\frac{Z_1}{Z_2}\right) = \theta_1 - \theta_2 \\ = 53.1^\circ - (-45^\circ) = 98.1^\circ$$

Example 14

Three complex numbers are given as

$$Z_1 = -1 - i; Z_2 = 3 - i\sqrt{3}; Z_3 = -1 + i\sqrt{3}$$

Find

- (a) $\left|\frac{Z_1}{Z_2}\right|$
- (b) $arg\left(\frac{Z_2}{Z_1 Z_3}\right)$
- (c) $\left|\frac{Z_1^2}{Z_2^3 Z_3}\right|$
- (d) $arg\left(\frac{Z_3^3 Z_2^2}{Z_1}\right)$

Solution

$$|Z_1| = \sqrt{(-1)^2 + (-1)^2} = \sqrt{2}$$

$$arg(Z_1) = \tan^{-1}\left(\frac{-1}{-1}\right) = -135^\circ = -\frac{3\pi}{4}$$

$$|Z_2| = \sqrt{3^2 + (\sqrt{3})^2} = 2\sqrt{3}$$

$$arg(Z_2) = \tan^{-1}\left(-\frac{\sqrt{3}}{3}\right) = -30^\circ = -\frac{\pi}{6}$$

$$|Z_3| = \sqrt{(-1)^2 + (\sqrt{3})^2} = 2$$

$$arg(Z_3) = \tan^{-1}\left(\frac{\sqrt{3}}{-1}\right) = 120^\circ = -\frac{2\pi}{3}$$

$$(a) \left|\frac{Z_1}{Z_2}\right| = \frac{|Z_1|}{|Z_2|} = \frac{\sqrt{2}}{2}$$

$$(b) arg\left(\frac{Z_2}{Z_1 Z_3}\right) = arg Z_2 - arg(Z_1 Z_3) \\ = arg Z_2 - arg Z_1 - arg Z_3 \\ = -30^\circ + 135^\circ - 120^\circ = -15^\circ = -\frac{\pi}{12}$$

$$(c) \left|\frac{Z_1^2}{Z_2^3 Z_3}\right| = \frac{|Z_1|^2}{|Z_2|^3 |Z_3|} = \frac{2}{24\sqrt{3}(2)} = \frac{\sqrt{3}}{72}$$

$$\begin{aligned}
 \text{(d) } \arg\left(\frac{Z_3^3 Z_2^2}{Z_1}\right) &= 53.1^\circ + 22.6^\circ = 75.7^\circ \\
 &= \arg(Z_3^3) + \arg(Z_2^2) - \arg(Z_1) \\
 &= 3\arg(Z_3) + 2\arg(Z_2) - \arg(Z_1) \\
 &= 3(120^\circ) - 2(30^\circ) + 135^\circ = 75^\circ = \frac{5\pi}{12}
 \end{aligned}$$

Note: the reader should correlate the computations of arguments $Z_1 Z_2$ and $\frac{Z_1}{Z_2}$ with the laws of logarithms

Example 15

- (a) Given that $Z_1 = 3 + 4i$, $Z_2 = 12 + 5i$ find
- $|Z_1 Z_2|$
 - $\arg(Z_1 Z_2)$
 - $\left|\frac{Z_1}{Z_2}\right|$
 - $\arg\left(\frac{Z_1}{Z_2}\right)$

Solution

$$|Z_1| = \sqrt{(3)^2 + (4)^2} = 5$$

$$\arg(Z_1) = \tan^{-1}\left(\frac{4}{3}\right) = 53.1^\circ$$

$$|Z_2| = \sqrt{(12)^2 + (5)^2} = 13$$

$$\arg(Z_2) = \tan^{-1}\left(\frac{5}{12}\right) = 22.6^\circ$$

$$(i) |Z_1 Z_2| = |Z_1| |Z_2| = 5 \times 13 = 65$$

$$(ii) \arg(Z_1 Z_2) = \arg(Z_1) + \arg(Z_2)$$

Solving equations of higher order

When one or more roots of a complex number is(are) given, their conjugates are also the roots of the same equation

To prove that a certain root is a factor of a complex function, we either use long division to show that the quotient of division is zero or we substitute the factor given into the equation to note the remainder or we get the product of the already existing roots and then carry on long division to observe the remainder or we use the synthetic approach

Please find free notes, tests and marking guides of physics, chemistry, biology and mathematics from: digitalteachers.co.ug

- $$= 53.1^\circ + 22.6^\circ = 75.7^\circ$$
- (iii) $\left|\frac{Z_1}{Z_2}\right| = \frac{|Z_1|}{|Z_2|} = \frac{5}{13}$
- (iv) $\arg\left(\frac{Z_1}{Z_2}\right) = \arg(Z_1) - \arg(Z_2)$
 $= 53.1^\circ - 22.6^\circ = 30.5^\circ$
- (b) Express $Z = -1 - i\sqrt{3}$ in modulus-argument form. Hence find $\frac{1}{Z}$ in form $a + bi$ where a and b are real numbers

Solution

$$|Z| = \sqrt{(-1)^2 + (-\sqrt{3})^2} = 2$$

$$\arg(Z) = \tan^{-1}\left(\frac{-\sqrt{3}}{-1}\right) = -120^\circ = -\frac{2}{3}\pi$$

$$\therefore Z = 2\left(\cos\frac{2\pi}{3} - i\sin\frac{2\pi}{3}\right)$$

$$\text{Hence, } \frac{1}{Z} = Z^{-1} = 2^{-1}\left(\cos\frac{2\pi}{3} - i\sin\frac{2\pi}{3}\right)^{-1}$$

$$= \frac{1}{2}\left(\cos\left(-\frac{2\pi}{3}\right) - i\sin\left(-\frac{2\pi}{3}\right)\right)$$

$$= \frac{1}{2}\left(\cos\left(\frac{2\pi}{3}\right) + i\sin\left(\frac{2\pi}{3}\right)\right)$$

$$= -\frac{1}{4} + i\frac{\sqrt{3}}{4}$$

Example 16

Given that $(1 + 3i)$ and $(2 - i)$ are roots of the equation

$$aZ^4 + bZ^3 + cZ^2 + dZ + e = 0, \text{ find}$$

- The other two roots
- The sum of the four roots
- The product of the four roots

Solution

- (i) Since $1 + 3i$ and $2 - i$ are roots of the equation, then their conjugates are also roots of the same equations. Hence the other two roots are $1 - 3i$ and $2 + i$.
- (ii) Sum of roots = $(1 + 3i) + (1 - 3i) + (2 - i) + (2 + i) = 6$
- (iii) Products of roots
 $= (1 + 3i)(1 - 3i)(2 - i)(2 + i) = 6$
 $= (1 - 9i^2)(4 - i^2)$
 $= (1 + 9)(4 + 1) = 50$

Example 17

Show that $Z_1 = 2 + 3i$ is a root of the equation $Z^4 - 5Z^3 + 18Z^2 - 17Z + 13 = 0$

Hence find the other remaining roots

Solution

Approach 1

Given $2 + 3i$ is a root, its conjugate $2 - 3i$ is also a root of the equation

The equation of these two roots

Sum of roots $2 + 3i + 2 - 3i = 4$

Product of roots = $(2 + 3i)(2 - 3i) = 13$

The equation is $Z^2 - 4Z + 13 = 0$

Using long division

Let $f(Z) = Z^4 - 5Z^3 + 18Z^2 - 17Z + 13$

$$\begin{array}{r}
 \overline{Z^2 - Z + 1} \\
 Z^2 - 4Z + 13 \bigg) Z^4 - 5Z^3 + 18Z^2 - 17Z + 13 \\
 \underline{Z^4 - 4Z^3 + 13Z^2} \\
 -Z^3 + 5Z^2 - 17Z + 13 \\
 \underline{-Z^3 + 4Z^2 - 13Z} \\
 Z^2 - 4Z + 13 \\
 \underline{Z^2 - 4Z + 13} \\
 0 + 0 + 0
 \end{array}$$

Since the remainder is zero, $Z^2 - Z + 1$ is also a factor of $f(Z)$

$\Rightarrow f(Z) = (Z^2 - 4Z + 13)(Z^2 - Z + 1)$

Either $Z^2 - 4Z + 13 = 0$ or $Z^2 - Z + 1 = 0$

Factors of $Z^2 - Z + 1$

$Z = \frac{1 \pm \sqrt{1^2 - 4(1)(1)}}{2(1)} = \frac{1 \pm i\sqrt{3}}{2}$

The roots are $2 \pm 3i$ and $\frac{1 \pm i\sqrt{3}}{2}$

Approach 2

Taking $Z = 2 + 3i$ and substituting in the given equation

LHS = $(2 + 3i)^4 - 5(2 + 3i)^3 + 18(2 + 3i)^2 - 17(2 + 3i) + 13 = 0$ (RHS)

$Z_1 = 2 + 3i$ is a root

This means $Z_2 = 2 - 3i$ is also a root of the equation as it is a conjugate of the given root.

Given $f(Z) = Z^4 - 5Z^3 + 18Z^2 - 17Z + 13 = 0$

Sum of roots = 5 and

Product of roots = 13

Let the other roots be α and β

Sum of the roots = $2 + 3i + 2 - 3i + \alpha + \beta = 5$

$4 + \alpha + \beta = 5$

$\alpha + \beta = 1$

$\alpha = (1 - \beta)$ (i)

Product of roots = $(2 + 3i)(2 - 3i)\alpha\beta = 13$

$13\alpha\beta = 13$

$\alpha\beta = 1$ (ii)

Substituting (i) into (ii)

$(1 - \beta)\beta = 1$ i.e. $\beta^2 - \beta + 1 = 0$

$\beta = \frac{1 \pm \sqrt{1^2 - 4(1)(1)}}{2(1)} = \frac{1 \pm i\sqrt{3}}{2}$

∴ The roots are $2 \pm 3i$ and $\frac{1 \pm i\sqrt{3}}{2}$

Approach 3: using synthetic method

$2 + 3i$	1	-5	18	-17	13
	0	$2+3i$	$-15-3i$	$15+3i$	-13
	1	$-3 + 3i$	$3 -3i$	$-2+3i$	0

Since the last value in the table is zero, therefore $2 + 3i$ is a root of the equation. Other roots can be obtained as shown above.

Illustration of the synthetic method

Procedure

- (a) Write down the root and coefficients of the expression in the first row (as shown above)
- (b) Write zero immediately below the first coefficient (this is the only entry in the second row that is simply written, the other are to be obtained by multiplication)
- (c) At the first coefficient to zero to get the first entry in the third row
- (d) Obtain the second entry in the second row by multiplying 1 by $2 + 3i$, then add to -5 to get the second entry in the third row i.e. $-3 + 3i$
- (e) Repeat (d) by multiplying $-3 + 3i$ to get the third entry in the second row, this entry is added to 18 to get to get the third row i.e. $3 - 3i$. continue with this trend up to the last entry. If the last entry in the table is zero, then the value being tested is a root.

Example 18

Show that $Z1 = 1 + i$ is a root of the equation $Z^4 - 6Z^3 + 25Z^2 - 34Z + 26 = 0$

Solution

Using synthetic division

$1 + i$	1	-6	25	-34	26
	0	$2+i$	$-6-4i$	$21+13i$	-26
	1	$-5 + i$	$17 - 4i$	$-3+ 13i$	0

Since the last entry in the table is zero, $1 + i$ is a root.

The conjugate $1 - i$ is also a root

Let the other roots be α and β

Sum of roots = $1 + i + 1 - i + \alpha + \beta = 6$

$2 + \alpha + \beta = 6$

$\alpha + \beta = 4$

$\alpha = 4 - \beta$ (i)

Product of roots $(1 + i)(1 - i)\alpha\beta = 26$

$2\alpha\beta = 26$

$A\beta = 13$ (ii)

Substituting eqn.(i) into eqn. (ii)

$(4 - \beta)\beta = 13$

$\beta^2 - 4\beta + 13 = 0$

$\beta = \frac{4 \pm \sqrt{16 - 4(1)(13)}}{2(1)} = \frac{4 \pm \sqrt{-36}}{2} = \frac{4 \pm 6i}{2}$

$= 2 \pm 3i$

Hence the other roots are $2 + 3i$ and $2 - 3i$

Revision exercise 2

- Given $Z_1 = 7 - 4i$ and $Z_2 = -1 + 3i$, express in the modulus-argument form the following
 - $Z_1 Z_2$
 $\{r = 25.45 [\cos(0.437\pi) + i\sin(0.437\pi)]\}$
 - $\left| \frac{Z_1}{Z_2} \right|$
 $\{p = 2.55[\cos(1.233\pi) + i\sin(1.233\pi)]\}$
- Find the modulus and the principal arguments of
 - $\frac{1-i}{1+i} \left[1, \frac{-\pi}{3} \right]$
 - $\frac{-1-7i}{4+3i} \left[\sqrt{2}, \frac{-3\pi}{4} \right]$
 - $\frac{1+i}{2-i} \left[\frac{\sqrt{10}}{5}, 125 \right]$
 - $\frac{(3+i)^2}{1-i} [2\sqrt{5}, 143]$
- If z_1 and z_2 are complex numbers, solve the simultaneous equation, giving your answer in the form $a + bi$.
 $4z_1 + 3z_2 = 23$
 $z_1 + iz_2 = 6 [2 + 3i, 5 - 4i]$
- Given that $2 + i$ is a root of the equation $z^3 - 11z + 20 = 0$. Find the remaining roots $[2 - i, -4]$
- Show that $2 + i$ is a root of the equation $2z^3 - 9z^2 + 14z - 5 = 0$. Hence find other roots $[2 - i, \frac{1}{2}]$
- Find equation whose roots are $-1 \pm i$, where $i = \sqrt{-1}$ $[z^2 + 2z + 2 = 0]$
- Show that $z = 1$ is a root of the equation $z^3 - 5z^2 + 9z - 5 = 0$ $[2 - i, 2 + i]$
- The complex number satisfies $\frac{z}{z+2} = 2 - i$ find the real and imaginary parts of z , and the modulus and argument of z . $[Re(z) = -3, Im(z) = -1, \sqrt{10}, -2.82\text{rads}]$
- One root of the equation $z^2 + az + b = 0$ where a and b are real constants is $2 + 3i$. Find the values of a and b $[a = -4, b = 13]$
- If $z_1 = 2 \left(\cos \frac{2\pi}{3} + i\sin \frac{2\pi}{3} \right)$ and $z_2 = 6 \left(\cos \left(\frac{-3\pi}{4} \right) + i\sin \left(\frac{-3\pi}{4} \right) \right)$ find
 - $\left| \frac{z_1}{z_2} \right| \left[\frac{1}{3} \right]$
 - $arg \left(\frac{z_1}{z_2} \right) \left[\frac{17\pi}{12} \right]$
 - $\left| \frac{z_2}{z_1} \right| [3]$
 - $arg \left(\frac{z_2}{z_1} \right) \left[\frac{-17\pi}{12} \right]$
- If z_1 and z_2 are two complex numbers such that $|z_1 - z_2| = |z_1 + z_2|$. Show that the difference of their arguments is $\frac{\pi}{2}$ or $\frac{3\pi}{2}$.
- Find the modulus and argument of $\frac{(2-i)^2(3i-1)}{i+3}$ $[5, 0.6435 \text{ rad}]$
- If $z_1 = \frac{1+7i}{1-i}$ and $z_2 = \frac{17-7i}{2+2i}$ find the moduli of
 - z_1 $[5]$
 - z_2 $[6.5]$
 - $z_1 + z_2$ $[2.061]$
 - $z_1 z_2$ $[32.5]$

Demoivre's theorem

This states that for all rational integers

$$r(\cos\theta + i\sin\theta)^n = r(\cos n\theta + i\sin n\theta)$$

The theorem can be proved by induction approach or otherwise

By induction

$$\text{Given that } (\cos\theta + i\sin\theta)^n = \cos n\theta + i\sin n\theta$$

Suppose $n = 1$

$$\cos\theta + i\sin\theta = \cos 1\theta + i\sin 1\theta$$

$\Rightarrow \cos\theta + i\sin\theta = \cos\theta + i\sin\theta$ i.e. the proof holds for $n = 1$

Suppose $n = k$

$$(\cos\theta + i\sin\theta)^k = \cos k\theta + i\sin k\theta$$

For $n = k + 1$

$$(\cos\theta + i\sin\theta)^{k+1} = (\cos\theta + i\sin\theta)^k (\cos\theta + i\sin\theta)^1$$

$$\begin{aligned}
&= (\cos k\theta + i\sin k\theta)(\cos\theta + i\sin\theta) \\
&= \cos k\theta\cos\theta + i\cos k\theta\sin\theta + i\sin k\theta\cos\theta + i^2\sin k\theta\sin\theta \\
&= \cos k\theta\cos\theta - \sin k\theta\sin\theta + i(\cos k\theta\sin\theta + \sin k\theta\cos\theta) \\
&= \cos(k+1)\theta + i\sin(k+1)\theta
\end{aligned}$$

which is true when $n = k + 1$

Therefore the proof holds for all values of n

Using otherwise

Given $z = \cos\theta + i\sin\theta$

$$\begin{aligned}
Z^2 &= (\cos\theta + i\sin\theta)^2 \\
&= \cos^2\theta + 2i\sin\theta\cos\theta - \sin^2\theta \\
&= \cos^2\theta - \sin^2\theta + i2\sin\theta\cos\theta \\
&= \cos 2\theta + i\sin 2\theta
\end{aligned}$$

$$\begin{aligned}
Z^3 &= (\cos 2\theta + i\sin 2\theta)^2(\cos\theta + i\sin\theta) \\
&= \cos 2\theta\cos\theta - \sin 2\theta\sin\theta + i(\sin 2\theta\cos\theta + \cos 2\theta\sin\theta) \\
&= \cos 3\theta + i\sin 3\theta
\end{aligned}$$

$\Rightarrow (\cos\theta + i\sin\theta)^n = \cos n\theta + i\sin n\theta$ hold for all positive values of n

Also, $(\cos\theta + i\sin\theta)^n = \cos n\theta + i\sin n\theta$ holds for fractional and negative indices

$$\begin{aligned}
\text{(a) } z^{-1} &= \frac{1}{z} = \frac{1}{\cos\theta + i\sin\theta} \\
&= \left(\frac{1}{\cos\theta + i\sin\theta}\right) \left(\frac{\cos\theta - i\sin\theta}{\cos\theta - i\sin\theta}\right) \\
&= \frac{\cos\theta - i\sin\theta}{(\cos^2\theta - i^2\sin^2\theta)} = \cos\theta - i\sin\theta \\
\Rightarrow z^{-1} &= \cos(-\theta) + i\sin(-\theta)
\end{aligned}$$

(b) suppose $n = -m$

$$\begin{aligned}
z^{-m} &= \frac{1}{z^m} = \frac{1}{(\cos\theta + i\sin\theta)^m} \\
&= \left(\frac{1}{\cos m\theta + i\sin m\theta}\right) \left(\frac{\cos m\theta - i\sin m\theta}{\cos m\theta - i\sin m\theta}\right)
\end{aligned}$$

$$\begin{aligned}
\Rightarrow (\cos\theta + i\sin\theta)^{-m} \\
&= \cos(-m\theta) + i\sin(-m\theta)
\end{aligned}$$

Hence the theorem holds for all values of n .

Applications of Demoivre's theorem

It is mainly employed in proving trigonometric functions and finding roots of complex function.

Proving identities

Example 19

By using Demoivre's theorem, show that

$$\text{(a) } \tan 5x = \frac{5\tan x - 10\tan^3 x + \tan^5 x}{1 - 10\tan^2 x + \tan^4 x}$$

Solution

$$\begin{aligned}
\cos 5x + i\sin 5x &= (\cos x + i\sin x)^5 \\
&= \cos^5 x + 5i\sin x\cos^4 x - 10\sin^2 x\cos^3 x - \\
&10i\sin^3 x\cos^2 x + \sin^4 x\cos x + i\sin^5 x
\end{aligned}$$

Equating real parts

$$\cos 5x = \cos^5 x - 10\cos^3 x\sin^2 x + \cos x\sin^4 x$$

Equating imaginary parts

$$\sin 5x = 5\cos^4 x\sin x - 10\cos^2 x\sin^3 x + \sin^5 x$$

$$\tan 5x = \frac{\sin 5x}{\cos 5x} = \frac{5\cos^4 x\sin x - 10\cos^2 x\sin^3 x + \sin^5 x}{\cos^5 x - 10\cos^3 x\sin^2 x + \cos x\sin^4 x}$$

Dividing terms of the R.H.S by $\cos^5 x$

$$\tan 5x = \frac{5\tan x - 10\tan^3 x + \tan^5 x}{1 - 10\tan^2 x + \tan^4 x}$$

$$\text{(b) } \frac{\cos 3x + i\sin 3x}{\cos 5x + i\sin 5x} = \cos 8x + i\sin 8x$$

Solution

$$\begin{aligned}
\frac{\cos 3x + i\sin 3x}{\cos 5x + i\sin 5x} &= \frac{(\cos x + i\sin x)^3}{(\cos x + i\sin x)^5} \\
&= (\cos x + i\sin x)^{3-5} \\
&= (\cos x + i\sin x)^{-2} \\
&= \cos 2x + i\sin 2x
\end{aligned}$$

$$\text{(c) } \frac{(\cos x + i\sin x)(\cos 2x + i\sin 2x)}{\cos^{\frac{x}{2}} + i\sin^{\frac{x}{2}}} = \cos \frac{5x}{2} + i\sin \frac{5x}{2}$$

Solution

$$\begin{aligned}
&\frac{(\cos x + i\sin x)(\cos 2x + i\sin 2x)}{\cos^{\frac{x}{2}} + i\sin^{\frac{x}{2}}} \\
&= \frac{(\cos x + i\sin x)^1 (\cos x + i\sin x)^2}{(\cos x + i\sin x)^{\frac{1}{2}}} \\
&= (\cos x + i\sin x)^{\frac{3}{2}}
\end{aligned}$$

$$= (\cos x + i \sin x)^{1+2-\frac{1}{2}}$$

$$= (\cos x + i \sin x)^{\frac{5}{2}} = \cos \frac{5x}{2} + i \sin \frac{5x}{2}$$

(d) $16 \sin^5 x = \sin 5x - 5 \sin 3x + 10 \sin x$

Given $Z = \cos x + i \sin x$

$$\bar{Z} = \cos x - i \sin x$$

$$(Z - \bar{Z}) = 2i \sin x$$

This means that $(Z - \bar{Z})^n = 2i \sin nx$

$$(Z - Z^*)^5 = 2i \sin 5x = 32i \sin^5 x$$

$$(Z - \bar{Z})^5$$

$$= Z^5 - 5Z^4\bar{Z} + 10Z^3\bar{Z}^2 + 10Z^2(-\bar{Z})^3 + 5Z\bar{Z}^4 - \bar{Z}^5$$

$$= Z^5 - 5Z^3 + 10Z - 10(\bar{Z}) + 5\bar{Z}^3 - \bar{Z}^5$$

$$= [Z^5 - \bar{Z}^5] - 5[Z^3 - \bar{Z}^3] + 10[Z - \bar{Z}]$$

$$= 2i \sin 5x - 10i \sin 3x + 20i \sin x$$

$$\Rightarrow 32i \sin^5 x = 2i \sin 5x - 10i \sin 3x + 20i \sin x$$

$$\therefore 16 \sin^5 x = \sin 5x - 5 \sin 3x + 10 \sin x$$

Finding roots

Suppose that $z = r(\cos \theta + i \sin \theta)$

Then $z^n = r^n(\cos n\theta + i \sin n\theta)$

$$z^{\frac{1}{n}} = r^{\frac{1}{n}} \left(\cos \frac{1}{n} \theta + i \sin \frac{1}{n} \theta \right)$$

The general expression for finding the roots of a complex function is given by

$$z = r[\cos(\theta + 2\pi k) + i \sin(\theta + 2\pi k)] \text{ where } k = 0, 1, 2, \dots k \text{ and } \theta \text{ is usually in radians.}$$

Now for n^{th} root, we have

$$z^n = r^n[\cos n(\theta + 2\pi k) + i \sin n(\theta + 2\pi k)]$$

$$z^{\frac{1}{n}} = r^{\frac{1}{n}} \left(\cos \frac{1}{n} (\theta + 2\pi k) + i \sin \frac{1}{n} (\theta + 2\pi k) \right)$$

Example 20

Use De Moivre's theorem to find the square root of

(a) $3 + 4i$

Solution

$$|z| = \sqrt{9 + 16} = 5$$

$$\theta = \tan^{-1} \frac{4}{3} = 53.1^\circ = 0.295\pi$$

The principal angle lies in the first quadrant

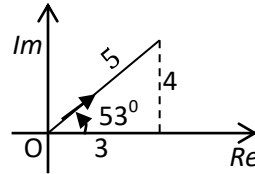

$$z = 5[\cos(0.295\pi + 2\pi k) + i \sin(0.295\pi + 2\pi k)]$$

$$z^{\frac{1}{2}}$$

$$= 5^{\frac{1}{2}} \left[\cos \left(\frac{0.295\pi + 2\pi k}{2} \right) + i \sin \left(\frac{0.295\pi + 2\pi k}{2} \right) \right]$$

Substituting for $k = 0$

$$z_1^{\frac{1}{2}} = 5^{\frac{1}{2}} \left[\cos \left(\frac{0.295\pi}{2} \right) + i \sin \left(\frac{0.295\pi}{2} \right) \right] = -2 - i$$

$$\therefore \sqrt{3 + 4i} = 2 \pm i$$

(b) $-3 - 4i$

Solution

$$|z| = \sqrt{9 + 16} = 5$$

$$\theta = \tan^{-1} \frac{-4}{-3} = -127^\circ = -0.7\pi$$

The principal angle lies in the third quadrant

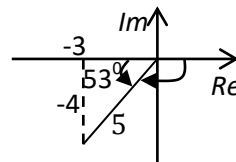

$$z = 5[\cos(0.295\pi + 2\pi k) + i \sin(0.295\pi + 2\pi k)]$$

$$z^{\frac{1}{2}} = 5^{\frac{1}{2}} \left[\cos \left(\frac{0.295\pi + 2\pi k}{2} \right) + i \sin \left(\frac{0.295\pi + 2\pi k}{2} \right) \right]$$

Substituting for $k = 0$

$$z_1^{\frac{1}{2}} = 5^{\frac{1}{2}} \left[\cos \left(\frac{0.295\pi}{2} \right) + i \sin \left(\frac{0.295\pi}{2} \right) \right] = -2 - i$$

Substituting for $k = 1$

$$z_2 = 5^{\frac{1}{2}} \left[\cos\left(\frac{0.295\pi+2\pi}{2}\right) + i \sin\left(\frac{0.295\pi+2\pi}{2}\right) \right]$$

$$= \pm(1-2i)$$

$$\therefore \sqrt{-3 - 4i} = \pm(1 - 2i)$$

(c) $5 - 12i$

Solution

$$|z| = \sqrt{(25 + 144)} = 13$$

$$\theta = \tan^{-1} \frac{-12}{5} = -67.4^\circ = -0.374\pi$$

The principal angle lies in the third quadrant

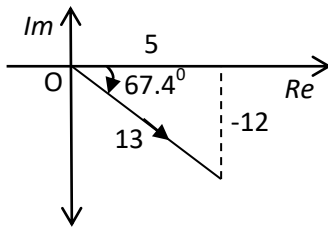

$$z = 13[\cos(-0.374\pi + 2\pi k) + i \sin(-0.374\pi + 2\pi k)]$$

$$z^{\frac{1}{2}} = 13^{\frac{1}{2}} \left[\cos\left(\frac{-0.374\pi+2\pi k}{2}\right) + i \sin\left(\frac{-0.374\pi+2\pi k}{2}\right) \right]$$

Substituting for $k = 0$

$$z_1 = 13^{\frac{1}{2}} \left[\cos\left(\frac{-0.374\pi}{2}\right) + i \sin\left(\frac{-0.374\pi}{2}\right) \right]$$

$$= 3 - 2i$$

Substituting for $k = 1$

$$z_2 = 13^{\frac{1}{2}} \left[\cos\left(\frac{-0.374\pi+2\pi}{2}\right) + i \sin\left(\frac{-0.374\pi+2\pi}{2}\right) \right]$$

$$= -3 + 2i$$

$$\therefore \sqrt{5 - 12i} = \pm(3 - 2i)$$

Example 21

(a) Use roots $1, \alpha$ and α^2 of unity. Hence show that $1 + \alpha + \alpha^2 = 0$

Solution

$$\text{Let } \sqrt[3]{1} = z$$

$$z = 1^{\frac{1}{3}} = (\cos 0^\circ + i \sin 0^\circ) \text{ (In mod-Arg form)}$$

Please find free notes, tests and marking guides of physics, chemistry, biology and mathematics from: digitalteachers.co.uk

$$= [\cos(0 + 2\pi k) + i \sin(0 + 2\pi k)]^{\frac{1}{3}}, k = 0, 1, 2$$

$$= \cos\left(\frac{2\pi k}{3}\right) + i \sin\left(\frac{2\pi k}{3}\right)$$

When $k = 0$

$$z_1 = \cos 0^\circ + i \sin 0^\circ = 1$$

When $k = 1$

$$z_2 = \cos\left(\frac{2\pi}{3}\right) + i \sin\left(\frac{2\pi}{3}\right) = -\frac{1}{2} + i \frac{\sqrt{3}}{2}$$

When $k = 2$

$$z_3 = \cos\left(\frac{4\pi}{3}\right) + i \sin\left(\frac{4\pi}{3}\right) = -\frac{1}{2} - i \frac{\sqrt{3}}{2}$$

$$\therefore \text{the cube roots are } 1, -\frac{1}{2} \pm i \frac{\sqrt{3}}{2}$$

Using otherwise

Taking

$$z = 1^{\frac{1}{3}}, \text{ then } z^3 - 1 = 0$$

$$\text{Let } f(z) = z^3 - 1$$

$$f(1) = 1^3 - 1 = 0$$

$\therefore z - 1$ is a factor.

Using long division

$$\begin{array}{r} z^2 + z + 1 \\ z-1 \overline{) z^3 - 1} \\ \underline{z^3 - z^2} \\ z^2 - 1 \\ \underline{z^2 - z} \\ z - 1 \end{array}$$

$$z^3 - 1 = (z - 1)(z^2 + z + 1)$$

Either $z - 1 = 0, z = 1$

Or $z^2 + z + 1 = 0$

$$z = \frac{-1 \pm \sqrt{1^2 - 4}}{2} = -\frac{1}{2} \pm i \frac{\sqrt{3}}{2}$$

$$\therefore \text{the cube roots are } 1, -\frac{1}{2} \pm i \frac{\sqrt{3}}{2}$$

Hence

Letting $\alpha = -\frac{1}{2} + i\frac{\sqrt{3}}{2}$, the

$$\alpha^2 = \left(-\frac{1}{2} + i\frac{\sqrt{3}}{2}\right)^2 = -\frac{1}{2} - i\frac{\sqrt{3}}{2}$$

Letting $\alpha = -\frac{1}{2} - i\frac{\sqrt{3}}{2}$, the

$$\alpha^2 = \left(-\frac{1}{2} - i\frac{\sqrt{3}}{2}\right)^2 = -\frac{1}{2} + i\frac{\sqrt{3}}{2}$$

Hence the roots can be written as 1, $\alpha + \alpha^2$

Adding these roots

$$1 - \frac{1}{2} - i\frac{\sqrt{3}}{2} - \frac{1}{2} + i\frac{\sqrt{3}}{2} = 0$$

(b) Evaluate $(-16)^{\frac{1}{4}}$

Solution

$$\text{Let } z = (-16)^{\frac{1}{4}} = 16^{\frac{1}{4}}(-1)^{\frac{1}{4}} = 2(-1)^{\frac{1}{4}}$$

$$= [\cos 180^\circ + i \sin 180^\circ]^{\frac{1}{4}}$$

$$= 2 \left[\cos \left(\frac{\pi + 2\pi k}{4} \right) + i \sin \left(\frac{\pi + 2\pi k}{4} \right) \right], k = 0, 1, 2, 3$$

When $k = 0$

$$z_1 = [\cos 45^\circ + i \sin 45^\circ] = \sqrt{2} + i\sqrt{2}$$

When $k = 1$

$$z_2 = [\cos 135^\circ + i \sin 135^\circ] = -\sqrt{2} + i\sqrt{2}$$

When $k = 2$

$$z_3 = [\cos 225^\circ + i \sin 225^\circ] = \sqrt{2} - i\sqrt{2}$$

When $k = 3$

$$z_3 = [\cos 315^\circ + i \sin 315^\circ] = -\sqrt{2} - i\sqrt{2}$$

$$\therefore (-16)^{\frac{1}{4}} = \pm(\sqrt{2} \pm i\sqrt{2})$$

Example 22

Evaluate $(1 + \sqrt{3}i)^{\frac{2}{3}}$

Solution

Please find free notes, tests and marking guides of physics, chemistry, biology and mathematics from: digitalteachers.co.ug

$$\begin{aligned} (1 + \sqrt{3}i)^{\frac{2}{3}} &= \left[(1 + \sqrt{3}i)^2 \right]^{\frac{1}{3}} \\ &= \left[(1 + \sqrt{3}i)(1 + \sqrt{3}i) \right]^{\frac{1}{3}} \\ &= \left[-2 + 2\sqrt{3}i \right]^{\frac{1}{3}} \end{aligned}$$

Let $z = -2 + 2\sqrt{3}i$

$$|z| = \sqrt{(-2)^2 + (2\sqrt{3})^2} = 4$$

$$\text{Arg}(z) = \tan^{-1} \left(\frac{2\sqrt{3}}{-2} \right) = -60^\circ = 120^\circ = \frac{2\pi}{3}$$

The principal angle lies in the second quadrant

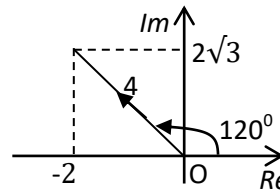

$$z = 4 \left[\cos \left(\frac{2\pi}{3} + 2\pi k \right) + i \sin \left(\frac{2\pi}{3} + 2\pi k \right) \right]$$

$$z^{\frac{1}{3}} = 4^{\frac{1}{3}} \left[\cos \left(\frac{2\pi + 6\pi k}{9} \right) + i \sin \left(\frac{2\pi + 6\pi k}{9} \right) \right]$$

When $k = 0$

$$\begin{aligned} z_1 &= 4^{\frac{1}{3}} \left[\cos \left(\frac{2\pi}{9} \right) + i \sin \left(\frac{2\pi}{9} \right) \right] \\ &= 1.2160 + 1.0204i \end{aligned}$$

When $k = 1$

$$\begin{aligned} z_2 &= 4^{\frac{1}{3}} \left[\cos \left(\frac{8\pi}{9} \right) + i \sin \left(\frac{8\pi}{9} \right) \right] \\ &= -1.4917 + 0.5429i \end{aligned}$$

When $k = 2$

$$\begin{aligned} z_3 &= 4^{\frac{1}{3}} \left[\cos \left(\frac{14\pi}{9} \right) + i \sin \left(\frac{14\pi}{9} \right) \right] \\ &= 0.2756 - 1.5633i \end{aligned}$$

$$\therefore (1 + \sqrt{3}i)^{\frac{2}{3}} = 1.2160 + 1.0204i, 1.4917 + 0.5429i, 0.2756 - 1.5633i$$

Example 23

Find the root of $z^4 + 4 = 0$ using De Moivre's theorem

$$z^4 = -4 = 4(-1 + 0i)$$

$$\arg(z) = \tan^{-1}\left(\frac{0}{-1}\right) = 180^\circ = \pi$$

$$\Rightarrow z^4 = 4[\cos 180^\circ + \sin 180^\circ]$$

$$z = 4^{\frac{1}{4}} \left[\cos\left(\frac{\pi + 2\pi k}{4}\right) + \sin\left(\frac{\pi + 2\pi k}{4}\right) \right]$$

When $k = 0$

$$z_1 = 4^{\frac{1}{4}} \left[\cos\left(\frac{\pi}{4}\right) + \sin\left(\frac{\pi}{4}\right) \right]$$

$$= \sqrt{2} \left(\frac{1}{\sqrt{2}} + \frac{1}{\sqrt{2}}i \right) = 1 + i$$

When $k = 1$

$$z_2 = 4^{\frac{1}{4}} \left[\cos\left(\frac{3\pi}{4}\right) + \sin\left(\frac{3\pi}{4}\right) \right]$$

$$= \sqrt{2} \left(\frac{-1}{\sqrt{2}} + \frac{1}{\sqrt{2}}i \right) = -1 + i$$

When $k = 2$

$$z_3 = 4^{\frac{1}{4}} \left[\cos\left(\frac{5\pi}{4}\right) + \sin\left(\frac{5\pi}{4}\right) \right]$$

$$= \sqrt{2} \left(-\frac{1}{\sqrt{2}} - \frac{1}{\sqrt{2}}i \right) = -1 - i$$

When $k = 3$

$$z_4 = 4^{\frac{1}{4}} \left[\cos\left(\frac{7\pi}{4}\right) + \sin\left(\frac{7\pi}{4}\right) \right]$$

$$= \sqrt{2} \left(\frac{1}{\sqrt{2}} - \frac{1}{\sqrt{2}}i \right) = 1 - i$$

\therefore the roots of $z^4 + 4 = 0$ are $1 \pm i$ and $-1 \pm i$

The locus of a complex number

This is an equation of a set of points representing a variable complex number or a path traced. It may be in the form of an equation of a circle or a straight line.

Example 24

Determine the locus of z if

Please find free notes, tests and marking guides of physics, chemistry, biology and mathematics from: digitalteachers.co.uk

(a) $|z - 4| = 3$

(b) $\arg(z+2) = \frac{\pi}{6}$

Solution

Let $z = x + iy$

(a) $|x + iy - 4| = 3$

$$|(x - 4) + iy| = 3$$

$$(x - 4)^2 + y^2 = 9$$

$$x^2 + y^2 - 8x + 7 = 0$$

The locus of z is a circle with centre $(4, 0)$

(b) $\arg(x + iy + 2) = \frac{\pi}{6}$

$$\arg((x+2) + iy) = \frac{\pi}{6}$$

$$\tan^{-1}\left(\frac{y}{x+2}\right) = \frac{\pi}{6}$$

$$\frac{y}{x+2} = \tan \frac{\pi}{6} = \frac{\sqrt{3}}{3}$$

$$\frac{y}{x+2} = \frac{\sqrt{3}}{3}$$

$$y = \frac{\sqrt{3}}{3}(x + 2)$$

The locus of z is a straight line

Example 25

Determine the locus of z if:

(a) $|z| = 2$ and sketch it

(b) $\arg(z - 1) = \frac{\pi}{4}$ and sketch it

(c) $2|z - 1| = |z + i|$

(d) $\arg\left(\frac{z-i}{z+1}\right) = \frac{\pi}{3}$

Solution

Let $z = x + iy$

(a) $|x + iy| = 2$ i.e. $\sqrt{x^2 + y^2} = 2$

$$x^2 + y^2 = 4 \text{ or } (x - 0)^2 + (y - 0)^2 = 2^2$$

The locus of z is a circle with centre $(0, 0)$ and radius 2 units

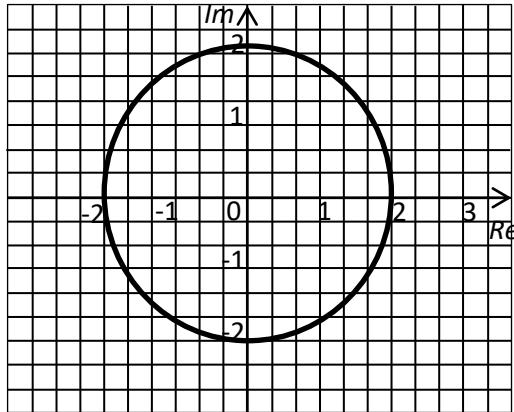

$$(b) \operatorname{Arg}[(x-1) + iy] = \frac{\pi}{4}$$

$$\tan^{-1}\left(\frac{y}{x-1}\right) = \frac{\pi}{4}$$

$$\frac{y}{x-1} = \tan \frac{\pi}{4} = 1$$

$$y = x - 1$$

The locus is a straight line

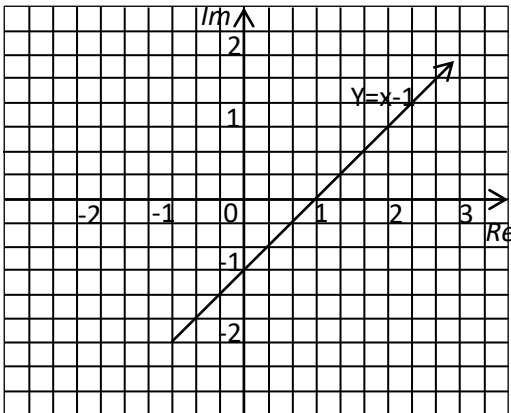

$$(c) 2|(x-1) + iy| = |x + i(y+1)|$$

$$\left[2\sqrt{(x-1)^2 + y^2}\right]^2 = \left[\sqrt{x^2 + (y+1)^2}\right]^2$$

$$3x^2 + 3y^2 - 8x - 2y + 3 = 0$$

$$x^2 + y^2 - \frac{8}{3}x - \frac{2}{3}y + 1 = 0$$

$$= \left(x - \frac{4}{3}\right)^2 + \left(y - \frac{1}{3}\right)^2 = -1 + \frac{16}{9} + \frac{1}{9}$$

$$= \left(x - \frac{4}{3}\right)^2 + \left(y - \frac{1}{3}\right)^2 = \frac{8}{9}$$

The locus of Z is a circle with the centre $\left(\frac{4}{3}, \frac{1}{3}\right)$ and radius $\sqrt{\frac{8}{9}} = \frac{2\sqrt{2}}{3}$

$$(d) \operatorname{arg}\left(\frac{x+iy-i}{x+iy+1}\right) = \frac{\pi}{3}$$

$$\operatorname{arg}\left(\frac{x+i(y-1)}{(x+1)+iy}\right) = \frac{\pi}{3}$$

$$\operatorname{arg}[x + i(y-1)] - \operatorname{arg}[x+1 + iy] = \frac{\pi}{3}$$

$$\tan^{-1}\left(\frac{y-1}{x}\right) - \tan^{-1}\left(\frac{y}{x+1}\right) = \frac{\pi}{3}$$

$$\frac{\left(\frac{y-1}{x}\right) - \left(\frac{y}{x+1}\right)}{1 + \left(\frac{y-1}{x}\right)\left(\frac{y}{x+1}\right)} = \sqrt{3}$$

$$\frac{y-x-1}{x^2+y^2+x-y} = \sqrt{3}$$

$$\sqrt{3}x^2 + \sqrt{3}y^2 + (\sqrt{3}+1)x - (\sqrt{3}+1)y + \frac{\sqrt{3}}{3} = 0$$

$$x^2 + y^2 + \left(\frac{3+\sqrt{3}}{3}\right)x - \left(\frac{3+\sqrt{3}}{3}\right)y + \frac{\sqrt{3}}{3} = 0$$

The locus is a circle with centre at $\left[-\frac{1}{6}(3 + \sqrt{3}), -\frac{1}{6}(3 + \sqrt{3})\right]$ and radius $\sqrt{\frac{2}{3}}$

Example 26

The complex number $z = \sqrt{3} + i$.
 \bar{Z} is the conjugate of Z .

(a) Express Z in the modulus argument form

$$|z| = \sqrt{(\sqrt{3})^2 + 1^2} = \sqrt{3+1} = 2$$

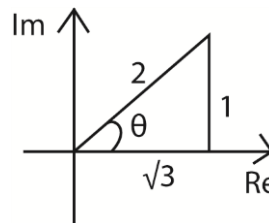

$$\tan \theta = \frac{1}{\sqrt{3}}$$

$$\theta = \operatorname{Arg}(z) = \tan^{-1}\left(\frac{1}{\sqrt{3}}\right) = \frac{\pi}{6}$$

$$\text{Hence } z = 2\left[\cos\left(\frac{\pi}{6}\right) + i\sin\left(\frac{\pi}{6}\right)\right]$$

or $z = 2[\cos 30^\circ + i\sin 30^\circ]$

- (i) On the same Argand diagram plot \bar{z} and $2\bar{z} + 3i$

$$\bar{z} = \sqrt{3} - i$$

$$|z| = \sqrt{(\sqrt{3})^2 + (-1)^2} = \sqrt{3+1} = 2$$

$$2\bar{z} + 3i = 2(\sqrt{3} - i) + 3i = 2\sqrt{3} + i$$

$$|2\bar{z} + 3i| = \sqrt{(2\sqrt{3})^2 + 1^2} = \sqrt{13}$$

Finding $\arg(\bar{z})$:

$$\text{Arg}(\bar{z}) = \tan^{-1}\left(-\frac{1}{\sqrt{3}}\right) = -30^\circ$$

Finding $\arg(2\bar{z} + 3i)$:

$$\text{Arg}(2\bar{z} + 3i) = \tan^{-1}\left(\frac{1}{2\sqrt{3}}\right) = 16.2^\circ$$

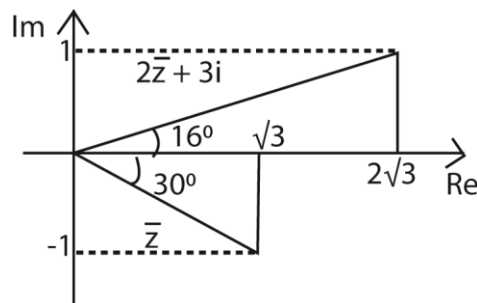

- (b) What are the greatest and least values of $|Z|$ if $|Z - 4| \leq 3$?

$$|z - 2| \leq 3$$

$$|x - 4 + iy| \leq 3$$

$$(x - 4)^2 + y^2 \leq 3$$

This is an equation of the circle with centre (4, 0) and radius 3.

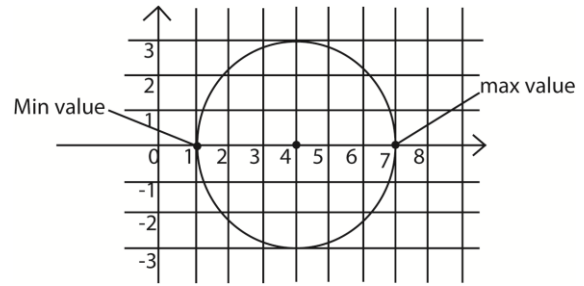

Greatest value of $|z| = 4 + 3 = 7$

Lowest value of $|z| = 4 - 3 = 1$

Example 27

- (a) Given that the complex number Z and its conjugate \bar{Z} satisfy the equation

$$Z\bar{Z} + 2iZ = 12 + 6i. \text{ Find } Z.$$

Let $z = x + iy$ then $\bar{z} = x - iy$

$$(x + iy)(x - iy) + 2i(x + iy) = 12 + 6i$$

$$x^2 + y^2 - 2y + 2xi = 12 + 6i$$

Equating imaginary parts

$$2xi = 6i$$

$$x = 3$$

Equating real parts

$$x^2 + y^2 - 2y = 12$$

By substituting for x

$$9 + y^2 - 2y = 12$$

$$y^2 - 2y - 3 = 0$$

$$(y - 3)(y + 1) = 0$$

$$y = 3 \text{ or } y = -1$$

when $y = 3$; $z = 3 + 3i$

when $y = -1$; $z = 3 - i$

\therefore the possible values of z are $3 + 3i$ and $3 - i$.

- (b) One root of the equation

$$Z^3 - 3Z^2 + 9Z + 13 = 0 \text{ is } 2 + 3i.$$

Determine other roots

Solution

Given root $2 + 3i$; its conjugate is also a root of the equation

The equation of these two is

$$z^2 - (\text{sum of roots})z + \text{product of roots} = 0$$

$$\text{Sum} = 2 + 3i + 2 - 3i = 4$$

Product of roots $= (2 + 3i)(2 - 3i) = 2 + 9 = 13$

$$z^2 - 4z + 13 = 0$$

$$z^2 - 4z + 13 \begin{array}{r} z + 1 \\ \hline z^3 - 3z^2 - 9z + 13 \\ -z^3 - 4z^2 - 13z \\ \hline z^2 - 4z + 13 \\ -z^2 - 4z + 13 \\ \hline \end{array}$$

$$(z^2 - 4z + 13)(z + 1) = 0$$

$$z + 1 = 0$$

$$z = -1$$

So the roots are $2 \pm 3i$ and -1

Example 28

(a) If $z_1 = \frac{2i}{1+3i}$ and $z_2 = \frac{3+2i}{5}$, find $|z_1 - z_2|$

Solution

$$\begin{aligned} z_1 - z_2 &= \frac{2i}{1+3i} - \frac{3+2i}{5} \\ &= \frac{10i - (1+3i)(3+2i)}{5(1+3i)} = \frac{10i - [3+2i+9i-6]}{5(1+3i)} \\ &= \frac{10i - 11i + 3}{5(1+3i)} = \frac{3-i}{5(1+3i)} \\ &= \frac{(3-i)(3-i)}{5(1+3i)(3-i)} = \frac{3-9i-i-3}{5(1+9)} = \frac{-i}{5} \end{aligned}$$

$$|z_1 - z_2| = \sqrt{0^2 - \left(-\frac{1}{5}\right)^2} = \frac{1}{5}$$

Alternative 2

$$\begin{aligned} z_1 &= \frac{2i}{1+3i} = \frac{2i(1-3i)}{(1+3i)(1-3i)} = \frac{2i+6}{1+9} \\ &= \frac{2i+6}{10} = \frac{3+2i}{5} \end{aligned}$$

$$z_1 - z_2 = \frac{3+2i}{5} - \frac{3+2i}{5} = \frac{-i}{5}$$

$$|z_1 - z_2| = \sqrt{0^2 - \left(-\frac{1}{5}\right)^2} = \frac{1}{5}$$

(b) Given the complex number $z = x + iy$

(i) Find $\frac{z+i}{z+2}$

$$\begin{aligned} \frac{z+i}{z+2} &= \frac{x+i(1+y)}{(x+2)+iy} = \frac{[x+i(1+y)][(x+2)-iy]}{[(x+2)+iy][(x+2)-iy]} \\ &= \frac{x[(x+2)-iy] - i(1+y)[(x+2)-iy]}{(x+2)^2 + y^2} \\ &= \frac{x^2 + 2x - ixy + i(x+2+xy+2y) + y + y^2}{(x+2)^2 + y^2} \\ &= \frac{x^2 + 2x + y^2 + y + i(2+x+2y)}{(x+2)^2 + y^2} \end{aligned}$$

(ii) Show that the locus of $\frac{z+i}{z+2}$ is a straight line when its imaginary part is zero. State the gradient of the line.

If imaginary part is zero

$$(2 + x + 2y) = 0$$

$$2y = -x - 2$$

$$y = -\frac{1}{2}x + 1$$

Comparing with $y = mx + c$

$$\text{The gradient} = -\frac{1}{2}$$

Example 29

(a) Given that a complex number Z^* and its conjugate satisfy the equation

$$ZZ^* + 2iZ = 12 + 6i, \text{ find the possible values of } Z.$$

Solution

Let $z^* = x + iy$, then $z = x - iy$

$$(x + iy)(x - iy) + 2i(x - iy) + 6i = 12 + 6i$$

$$x^2 + y^2 + 2y + 2xi = 12 + 6i$$

Equating real parts

$$x^2 + y^2 + 2y = 12$$

Equating imaginary parts

$$2x = 6 \Rightarrow x = 3$$

$$9 + y^2 + 2y = 12$$

$$y^2 + 2y - 3 = 0$$

$$(y - 1)(y + 3) = 0 \Rightarrow y = 1 \text{ or } y = -3$$

When $y = -3$; $z = 3 + 3i$ and

When $y = 1$, $z = 3 - i$

The possible values of z are $3 + 3i$ and $3 - i$

(b) Find the Cartesian equation, in its simplest form of the curve described by $|z - 3 + 6i| = 2|z|$ where z is the complex number $x + iy$.

Hence sketch an Argand diagram the region satisfying $|z - 3 + 6i| \leq 2|z|$

Solution

Substituting $z = x + iy$

$$|(x - 3) + i(y - 6)| = 2|x + iy|$$

$$(x - 3)^2 + (y - 6)^2 = 4(x^2 + y^2)$$

$$x^2 + y^2 - 6x + 12y + 45 = 4x^2 + 4y^2$$

$$x^2 + y^2 + 2x - 4y - 15 = 0$$

Hence sketching the region satisfying $|z - 3 + 6i| \leq 2|z|$

$$\text{i.e. } x^2 + y^2 + 2x - 4y - 15 \geq 0$$

substituting $(0, 0)$

$$\text{LHS} = -15; \text{RHS} = 0$$

Since $\text{LHS} < \text{RHS}$, the point $(0, 0)$ does not lie in the region $|z - 3 + 6i| \leq 2|z|$ therefore it lies in unwanted region.

$$\text{Now } x^2 + y^2 + 2x - 4y - 15 \geq 0$$

$$= (x + 1)^2 + (y - 2)^2 \geq 20$$

The locus is a circle centre $(-1, 2)$ and radius $\sqrt{20}$

The plot of $|z - 3 + 6i| \leq 2|z|$

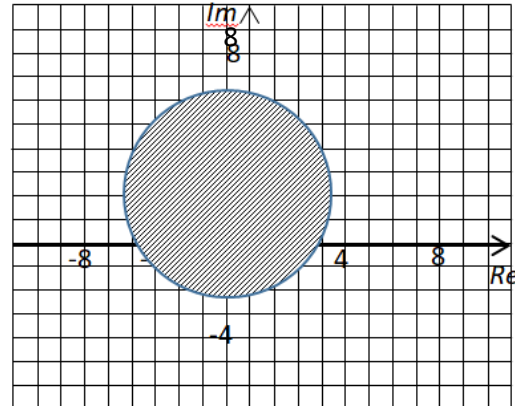

Example 30

If n is a variable and $z = 4n + 3i(1 - n)$, show that the locus of Z is a straight line. Determine the minimum value of $|z|$

Solution

Let $z = x + iy$

$$\Rightarrow x + iy = 4n + 3i(1 - n)$$

Equating real parts

$$x = 4n \Rightarrow n = \frac{x}{4}$$

Equating imaginary parts

$$y = 3(1 - n)$$

$$\Rightarrow y = 3\left(1 - \frac{x}{4}\right)$$

$y = -\frac{3x}{4} + 3$ which is a straight line with gradient $-\frac{3}{4}$ and intercept 3

Given $z = 4n + 3i(1 - n)$

$$|z|^2 = 16n^2 + 9(1 - n)^2$$

$$|z|^2 = 25n^2 - 18n + 9$$

The minimum value can be obtained by completing squares or differentiation

By completing squares

$$|z|^2 = 25\left(n^2 - \frac{18}{25}n + \frac{9}{25}\right)$$

$$\begin{aligned}
&= 25 \left[\left(n - \frac{9}{25} \right)^2 + \frac{9}{25} - \frac{81}{625} \right] \\
&= 25 \left[\left(n - \frac{9}{25} \right)^2 + \frac{144}{625} \right] \\
&= 25 \left(n - \frac{9}{25} \right)^2 + \frac{144}{25} \\
|z|^2 \text{ is minimum when } n &= \frac{9}{25} \\
|z|_{\min}^2 &= \frac{144}{25} \\
\Rightarrow |z|_{\min} &= \frac{12}{5}
\end{aligned}$$

By differentiation

$$2|z| \left| \frac{dz}{dn} \right| = 50n - 18 = 0$$

$$n = \frac{18}{50} = \frac{9}{25}$$

$$\begin{aligned}
|z_{\min}|^2 &= 25 \left(\frac{9}{25} \right)^2 - 18 \left(\frac{9}{25} \right) + 9 = \frac{3600}{625} \\
\Rightarrow |z|_{\min} &= \frac{60}{25} = \frac{12}{5}
\end{aligned}$$

Revision exercise 4

1. Use Demoiivre's theorem to show that
(a) $\cos 6x = \cos^6 x - 15\cos^4 x \sin x + 15\cos x \sin^4 x - \sin^6 x$

(b) $\tan 3x = \frac{3\tan x - \tan^3 x}{1 - 3\tan^2 x}$

2. (a) Evaluate $(1 + i\sqrt{3})^{\frac{2}{3}}$
[1.2160 + 1.0204i, -1.4917 + 0.5429i]

(b) Find the roots of $z^4 + 4 = 0$ using Demoiivre's theorem
[$1 \pm i$, $-1 \pm i$]

3. (a) Given that the complex number Z and its conjugate \bar{Z} satisfy the equation

$$z\bar{z} - 2Z + 2\bar{Z} = 5 - 4i. \text{ Find possible values of } Z. \text{ (06marks)}$$

[$Z = \pm 2 + 1$]

Example 31

Show that the locus of z if $\frac{z-3}{z+i}$ is wholly imaginary is a circle with centre at $\frac{3}{2} - \frac{1}{2}i$ and radius $\frac{1}{2}\sqrt{10}$

Solution

Let $z = x + iy$

$$\begin{aligned}
\frac{z-3}{z+i} &= \frac{(x-3+iy)}{(x+i(y+1))} \cdot \frac{(x-i(y+1))}{(x-i(y+1))} \\
&= \frac{x(x-3)+y(y+1)+i[(xy-(x-3)(y+1)]}{x^2+(y+1)^2}
\end{aligned}$$

If the above expression is wholly imaginary, then the real part must be zero

$$\text{i.e. } \frac{x(x-3)+y(y+1)}{x^2+(y+1)^2} = 0$$

$$\Rightarrow x^2 + y^2 - 3x + y = 0$$

$$\left(x - \frac{3}{2} \right)^2 + \left(y + \frac{1}{2} \right)^2 = \frac{9}{4} + \frac{1}{4} = \frac{10}{4}$$

The locus is a circle with centre with $\frac{3}{2} - \frac{1}{2}i$ and radius $\frac{1}{2}\sqrt{10}$

(b) Prove that if $\frac{Z-6i}{Z+8}$ is real, then the locus of the point representing the complex number Z is a straight line. (06marks) [y = $\frac{3}{4}x + 6$]

4. (a) Express $5 + 12i$ in polar form
[$5 + 12i = 13(\cos 67.38^\circ + i\sin 67.38^\circ)$]
Hence, evaluate $\sqrt[3]{5 + 12i}$, giving your answer in the form $a + ib$ where a and b are corrected to two decimal places. (12marks)

$$[z = 2.17 + 0.90i, -1.86 + 1.43i, -0.31 - 2.33i]$$

5. (a) The total impedance z in an electric circuit with two branches z_1 and z_2 is given

by $\frac{1}{z} = \frac{1}{z_1} + \frac{1}{z_2}$. Given that $z_1 = 3 + 4i$ and $z_2 = 5 + 5i$ where $i = \sqrt{-1}$, calculate the total impedance z in form $a + bi$

$$\left[z = \frac{275}{145} + i \frac{325}{145} \right]$$

(b) If n is a variable and $z = 4n + 3i(1 - n)$, show that the locus of Z is a straight line. Determine the minimum value of $|z|$ $\left[|z|_{\min} = \frac{12}{5} \right]$

6. Given that $z_1 = 3 + 4i$ and $z_2 = -1 + 2i$

(a) Express z_1 , z_2 , $z_1 + z_2$ and $z_1 - z_2$ in the form $r(\cos\theta + isin\theta)$

$$[z_1 = 5(\cos 53.1^\circ + isin 53.1^\circ),$$

$$z_2 = \sqrt{5}(\cos 116.6^\circ + isin 116.6^\circ),$$

$$z_1 + z_2 = 2\sqrt{10}(\cos 71.6^\circ + isin 71.6^\circ)$$

$$z_1 - z_2 = 2\sqrt{5}(\cos -153.4^\circ + isin -153.4^\circ)]$$

(b) Determine the angle between $z_1 + z_2$ and $z_1 - z_2$ $[225^\circ]$

7. Solve the simultaneous equation

$$z_1 + z_2 = 8$$

$$4z_1 - 3iz_2 = 26 + 8i$$

Using the values of z_1 and z_2 , find the modulus and argument of $z_1 + z_2 - z_1z_2$.

$$[z_1 = 8 + 2i, z_2 = -2i; 6.49, 75.96^\circ]$$

8. (a) Given that $z = 3 + 4i$, find the value of

$$\text{expression } z + \frac{25}{z} \quad [6]$$

Given that $\left| \frac{z-1}{z+1} \right| = 2$, show that the locus of the complex number is $x^2 +$

$$y^2 + \frac{10x}{3} + 1 = 0. \text{ Sketch the locus}$$

[The centre of the circle is $\left(\frac{-5}{3}, 0\right)$ it passes through -3 but does not touch the y -axis]

9. (a)(i) Express each of the following complex numbers in the form $a + bi$

$$z_1 = (1 - i)(1 + 2i) \quad [3 + i]$$

$$z_2 = \frac{2+6i}{3-i} \quad [2i]$$

$$z_3 = \frac{-4i}{1-i} \quad [2 - 2i]$$

(b) Find the modulus and argument of $z_1z_2z_3$ $[17.889, 63.4349^\circ]$

(c) Find the square root of $12i - 5 + 3i$ or $-2 - 3i$ $[1]$

10. (a) given that $z = \sqrt{3} + i$, find the modulus and argument

$$(i) \quad z^2 \left[4, \frac{\pi}{3} \right]$$

$$(ii) \quad \frac{1}{z} \left[\frac{1}{2}, -\frac{\pi}{6} \right]$$

(iii) Show in an Argand diagram the points representing complex numbers z , z^2 and $\frac{1}{z}$.

(b) In an Argand diagram, P represents a complex number z such that $2|z - 2| = |z - 6i|$ show that P lies on a circle, find

(i) The radius of this circle $[4.2164]$

(ii) The complex number represented by it centre $\left[z = \frac{8}{3} - 2i \right]$

11. (a) given the complex number $z_1 = 1 - i$, $z_2 = 7 + i$ represent z_1z_2 and $z_1 - z_2$ on the Argand diagram.

Determine the modulus and argument of $\frac{z_1 - z_2}{z_1z_2}$ $[0.6325, -124.7^\circ]$

(b) If z is a complex number of form $a + bi$, solve $\left(\frac{z-1}{z+1}\right)^2 = i$ $[z = 1 \pm i\sqrt{2}]$

12. (a) show the region represented by $|z - 2 + i| < 1$ on an Argand diagram [it is a circle of centre $(2, -1)$ and radius 1 unit, the circle is drawn with dotted line since the equation is less than, and the unwanted region is the area outside the circle]

(b) Express the complex number $z = 1 - i\sqrt{3}$ in modulus argument form and hence find z^2 and $\frac{1}{z}$ in the form $a + bi$

$$\left[z = 2 \left(\cos \left(-\frac{\pi}{3} \right) + isin \left(-\frac{\pi}{3} \right) \right), \right. \\ \left. z^2 = -2 - i2\sqrt{3}, \frac{1}{z} = \frac{1}{4} + i\frac{\sqrt{3}}{4} \right]$$

13. (a) Given that $z_1 = -i + 1$, $z_2 = 2 + i$, and $z_3 = 1 + 5i$, represent z_2z_3 , z_2z_1 , $\frac{1}{z_1}$ and $\frac{z_2z_3}{z_2 - z_1} + \frac{1}{z_1}$ on Argand diagram

(b) Prove that for positive integers $(\cos\theta + i\sin\theta)^n = \cos n\theta + i\sin n\theta$.

- Deduce that this formula is also true for negative values of n .
14. If z is a complex number, describe and illustrate on the Argand diagram the locus given by each of the following
- (a) $\left| \frac{z+i}{z-2} \right| = 3$
- [it is a circle centre $\left(\frac{9}{4}, \frac{1}{8}\right)$ radius 0. 8385]
- (ii) $\text{Arg}(z+3) = \frac{\pi}{6}$ [is it a straight line represented by equation $y = \frac{\sqrt{3}}{3}x + 3$]
15. (a) Use Demoiivre's theorem or otherwise to simplify $\frac{(\cos\theta + i\sin\theta)(\cos 2\theta + i\sin 2\theta)}{\cos \frac{\theta}{2} + i\sin \frac{\theta}{2}}$
- $\left[\cos\left(\frac{5\theta}{2}\right) + i\sin\left(\frac{5\theta}{2}\right) \right]$
- (b) Express $\frac{i}{4+6i}$ in modulus-argument form.
- $\{z = 0.1387[\cos(0.187\pi) + i\sin(0.187\pi)]\}$
- (c) Solve $(z + zz^*)z = 5 + 2z$ where z^* is the complex conjugate of z . [$z = 1 + 2i, z^* = 1 - 2i$]
16. Show that $2 + i$ is a root of the equation $2z^3 - 9z^2 + 14z - 5 = 0$. Hence find the other roots $2 - i$ and $\frac{1}{2}$
17. (a) find the equation whose root are $-1 \pm i$ where $i = \sqrt{-1}$ [$z^2 + 2z + 2 = 0$]
- (b) Find the sum of the first 10 terms of the series $1 + 2i + -4 - 8i + 16 + \dots$ [$205 + 410i$]
- (c) Prove by induction that $(\cos\theta + i\sin\theta)^n = \cos n\theta + i\sin n\theta$.
18. Show that $z = 1$ is a root of the equation $z^3 - 5z^2 + 9z - 5 = 0$. Hence solve the equation for other roots [$2 \pm i$]
19. (a) Use Demoiivre's theorem to express $\tan 5\theta$ in terms of $\tan\theta$.
- (b) Solve the equation $z^3 + 1 = 0$ [$-1, \frac{1}{2} + i\frac{\sqrt{3}}{2}, \frac{1}{2} - i\frac{\sqrt{3}}{2}$]
20. (a) Without using tables or calculators, simplify $\frac{(\cos \frac{\pi}{17} + i\sin \frac{\pi}{17})^8}{(\cos \frac{\pi}{17} - i\sin \frac{\pi}{17})^9}$ [-1]
- (b) Given that x and y are real, find the values of x and y which satisfy the equation: $\frac{2y+4i}{2x+y} - \frac{y}{x-i} = 0$ [$x = -1$ when $y = -2$ and $x = 1$ when $y = 2$]
21. Given the complex number $z = \frac{(3i+1)(i-2)^2}{i-3}$ (i) Determine z in form $a + bi$ where a and b are constant [$-4, -3i$]
- (ii) $\text{arg}(z)$ [-143.13°]
22. (a) Express the complex numbers $z_1 = 4i$ and $z_2 = 2 - 2i$ in trigonometric form $r(\cos\theta + i\sin\theta)$.
- [$z_1 = 4(\cos 90^\circ + i\sin 90^\circ)$, $z_2 = 2\sqrt{2}(\cos 45^\circ + i\sin 45^\circ)$]
- Hence or otherwise evaluate $\frac{z_1}{z_2} \left[\frac{1}{2} \right]$
- (b) Find the values of x and y in $\frac{x}{3+3i} - \frac{y}{2-3i} = \frac{6+2i}{1+8i}$ [$x = 2.8, y = 0.4$]
23. Find the fourth root of $4 + 3i$
- [$\pm(1.4760 + 0.23971i), \pm(0.2397 - 1.4760i)$]
24. (a) Given that $\frac{ix}{1+iy} = \frac{3x+4i}{x+3y}$; find the values of x and y [$x = 2, y = 1.5$ or $x = -2$ and $y = -1.5$]
- (b) If $z = x + iy$, find the equation of the locus $\left| \frac{z+3}{z-1} \right| = 4$ [$x^2 + y^2 - \frac{38}{15}x + \frac{7}{15} = 0$]
25. (a) given that the complex number z and its conjugate Z^* , satisfy the equation $zz^* + 3z^* = 34 - 12i$, find the value of z . [$z = 3 - 4i$ and $z = -6 + 4i$]
- (b) Find the Cartesian equation of the locus of a point P represented by equation $\left| \frac{z+3}{z+2-4i} \right| = i$ [the locus P is an equation of line $8y + 2x = 11$]

26. (a) form a quadratic equation having $-3 + 4i$ as one of its roots. $[z^2 + 6z + 25]$

(b) Given $z_1 = -1 + i\sqrt{3}$ and $z_2 = -1 - i\sqrt{3}$

(i) Express $\frac{z_1}{z_2}$ in form $a + i\sqrt{b}$, where a

and b are real number $\left[\frac{-1}{2} - i\frac{\sqrt{3}}{2}\right]$

(ii) Represent $\frac{z_1}{z_2}$ on an Argand diagram

(iii) find $\left|\frac{z_1}{z_2}\right|$ [1]

27. If $z = \frac{(2-i)(5+12i)}{(1+2i)^2}$

(a) Find the

(i) Modulus of z [5.814]

(ii) Argument z [-86.055°]

(b) Represent z on a complex plane

(c) Write z in the polar form [$z = 5.814(\cos(-86.055^\circ) + i\sin(-86.055^\circ))$ or $z = 5.814(\cos(0.47\pi) + i\sin(0.47\pi))$]

28. (a) the complex number $z = \sqrt{3} + i$. \bar{Z} is the conjugate of Z .

(i) Express Z in the modulus argument form

$[z = 2\left[\cos\left(\frac{\pi}{6}\right) + i\sin\left(\frac{\pi}{6}\right)\right]$ or $z = 2[\cos 30^\circ + i\sin 30^\circ]$

(ii) On the same Argand diagram plot \bar{Z} and $2\bar{Z} + 3i$

(b) What are the greatest and least values of $|Z|$ if $|Z - 4| \leq 3$?

[Greatest value of $|z| = 7$, Lowest value of $|z| = 1$]

29. (a) Given that the complex number Z and its conjugate \bar{Z} satisfy the equation

$Z\bar{Z} + 2iZ = 12 + 6i$. Find Z .

[possible values of z are $3 + 3i$ and $3 - i$]

(b) One root of the equation $Z^3 - 3Z^2 + 9Z + 13 = 0$ is $2 + 3i$. Determine other roots

[other roots are $2 - 3i$ and -1]

30. (a) If $z_1 = \frac{2i}{1+3i}$ and $z_2 = \frac{3+2i}{5}$, find $|z_1 - z_2|$

$\left[\frac{1}{5}\right]$

(b) Given the complex number $z = x + iy$

(i) Find $\frac{z+i}{z+2} \left[\frac{x^2+2x+y^2+y+i(2+x+2y)}{(x+2)^2+y^2} \right]$

(ii) Show that the locus of $\frac{z+i}{z+2}$ is a straight line when its imaginary part is zero. State the gradient of the line. $[y = -\frac{1}{2}x + 1]$

31. (a) Given that the complex number Z and its conjugate \bar{Z} satisfy the equation

$Z\bar{Z} - 2Z + 2\bar{Z} = 5 - 4i$. Find possible values of Z . $[Z = \pm 2 + 1]$

(b) Prove that if $\frac{Z-6i}{Z+8}$ is real, then the locus of the point representing the complex number Z is a straight line. $[y = \frac{3}{4}x + 6]$

32. (a) Express $5 + 12i$ in polar form

Hence, evaluate $\sqrt[3]{5 + 12i}$, giving your answer in the form $a + ib$ where a and b are corrected to two decimal places. (12marks)

$[\sqrt[3]{5 + 12i} = \sqrt[3]{13} \left[\cos\left(\frac{67.38+2\pi k}{3}\right) + i\sin\left(\frac{67.38+2\pi k}{3}\right) \right]$ taking $k = 0, 1, 2;$ 2.17 + 0.90i; -1.86 + 1.43i; -0.31 - 2.33i]

33. Show that the modulus of $\frac{(1-i)^6}{(1+i)} = 4\sqrt{2}$

**Thank you
Dr. Bbosa Science**