



Dr. Bhasa Science

Sponsored by
The Science Foundation College
Uganda East Africa
Senior one to senior six

+256 778 633682 0753 143413

Based on, Best for Science

digitalteachers.co.ug



Nuture your dreams



SENIOR FIVE TERM 3

TOPIC 5/6: CAPACITORS

Competency: The learner models capacitors for use in electronic devices.

Definition

A capacitor also known as a condenser, is a device which is used to store electric charge.

A capacitor consists of two metal plates separated by an insulator called dielectric usually air or oil.

A **dielectric** is a nonconductor of electric charge in which an applied electric field causes a displacement of charge but not flow of charge. Electrons within the atom of a dielectric are on average, displaced by an electric field with respect to the nucleus, giving rise to a dipole that has an electric moment in the direction of the field. In this case, we say the molecules have been polarized.

A dielectric does not only keep the two metal plates apart, but also increase the capacitance of a capacitor.

Charging and discharging a capacitor

A capacitor is charged when a battery or e.m.f source is connected across it.

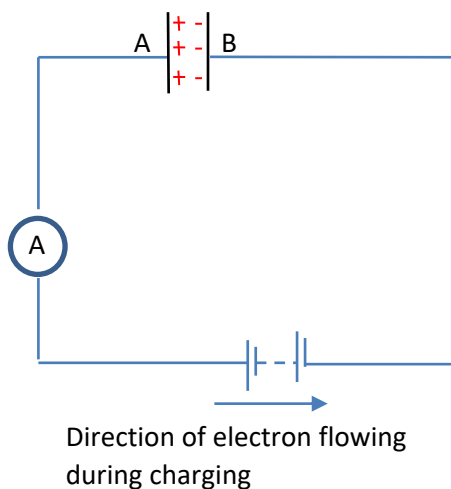

On connecting the battery across the capacitor, electrons are drawn from metal plate A by the positive terminal of the battery, whilst at the same time they are deposited on metal B by the action of negative terminal. Thus there is a momentary flow of current as indicated by the ammeter.

After some time, the number of electrons deposited on plate B keeps on reducing due to electrostatic force of repulsion between already deposited electrons and those that are flowing to plate B. At one point, no further deposition occurs. At this point, the potentials at A and B become equal to that across the battery and oppositely directed to it. The current drops to zero. The capacitor is said to be fully charged.

The charging process leaves A with a positive charge and B with an equal but negative charge.

When the battery is disconnected and the plates are joined by a wire, electrons flow from plate B to A until the positive charge on A is completely neutralized. A current thus flows for a time in the wire and at the end of time, the charges on the plates become zero. The capacitor is said to be discharged.

The graph below shows how the currents vary when the capacitor is being charged and when being discharged.

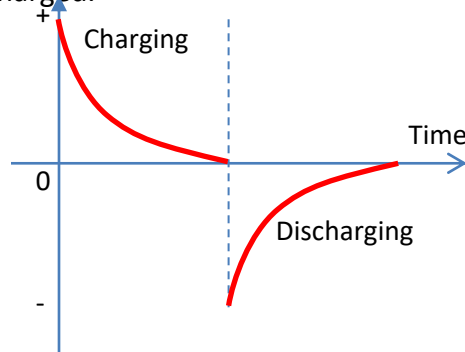

Capacitance

Capacitance of a capacitor is the ratio of the magnitude of charge on either plate of the capacitor to the potential difference between the plates.

Or

It is charge required to cause a potential difference of 1V between plates of the capacitor

$$C = \frac{Q}{V}$$

where C is capacitance, Q is the magnitude of charge on either plate and V is the potential difference between the plates.

The units of C is Coulomb per volt (CV^{-1}) or Farad (F). The farad is a very large unit, $1\mu F$ (micro) = $10^{-6}F$, nF (nanofarad) = $10^{-9}F$, 1mF (picofarad) = $10^{-12}F$.

Please find free new curriculum notes, exams and marking guides on digitlteachers.co.ug website

The Farad

The farad is the capacitance of a capacitor such that 1C of charge is stored when the p.d of 1V is applied.

$$\text{i.e. } 1\text{F} = \text{CV}^{-1}$$

Comparison of capacitances or measurement of capacitance of a capacitor

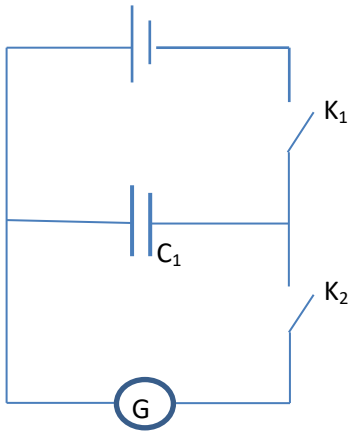

Large capacitances, of order micro-farads, can be compared with the aid of a ballistic galvanometer. The circuit is shown above. The capacitor of capacitance C_1 is charged by a battery of e.m.f V , and then discharged through ballistic galvanometer G . The corresponding deflection, θ_1 is noted.

The capacitor is now replaced by another capacitor C_2 , charged again by the battery, and the new deflection θ_2 is noted when the capacitor is discharged.

Now

$$\frac{Q_1}{Q_2} = \frac{\theta_1}{\theta_2}$$

$$\frac{C_1 V}{C_2 V} = \frac{\theta_1}{\theta_2}$$

$$\frac{C_1}{C_2} = \frac{\theta_1}{\theta_2}$$

If C_2 is a standard capacitor, whose capacitance is known, then the capacitance C_1 can be found

Factors that affect capacitance of a capacitor

- (i) The plate separation
- (ii) The area of overlap (or area common) between the plates
- (iii) The dielectric or medium between the plates, and most specifically the permittivity of the dielectric material.

Please find free new curriculum notes, exams and marking guides on digitlteachers.co.ug website

Experiments show the following

- (i) $C \propto \frac{1}{d}$
- (ii) $C \propto A$
- (iii) $C \propto \epsilon$

Experiment to verify that $C = \epsilon A/d$ for parallel plate capacitor.

(a) To show that $C \propto A$

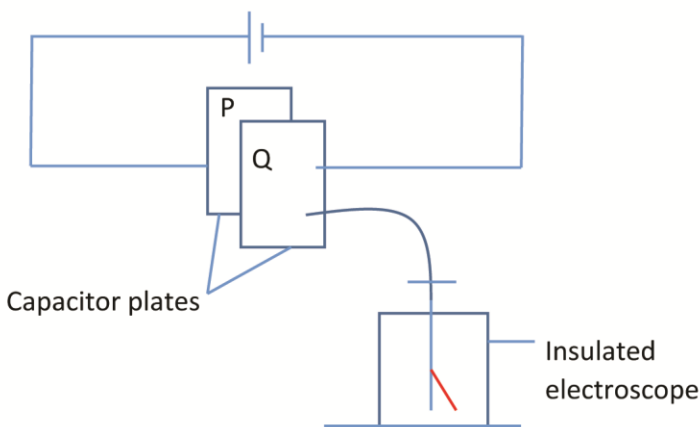

A p.d is set across the capacitor plates P and Q, by connecting a cell across it. One plate Q is connected to the cap of electroscopes. With the p.d constant and the plates in the above position with air in between them, the divergence of the leaf of electroscopes is noted.

Place P is then slid relative to Q keeping the separation constant, hence reducing the effective area of the plate. The divergence is seen to decrease.

Since divergence is proportional to charge on the plates, which in turn is proportional to the capacitance, C, then, C is reduced.

This shows that $C \propto A$

(b) To show that $C \propto 1/d$

The plate P is then slid back and separation between the plates is increased by moving P away from Q. The divergence of the leaf is observed to decrease. Since divergence of the leaf is proportional to charge on the plates, which in turn is proportional to capacitance C, then C is reduced. This shows that $C \propto 1/d$.

(c) To show that $C \propto \epsilon$

The position of P and the separation between the two plates are restored. A dielectric is then put in the space between the plates. The divergence of the leaf is seen to increase. Since divergence is proportional to the charge on the plates, which in turn is proportional to capacitance C, then C has increased. This shows that $C \propto \epsilon$.

Alternative experiments

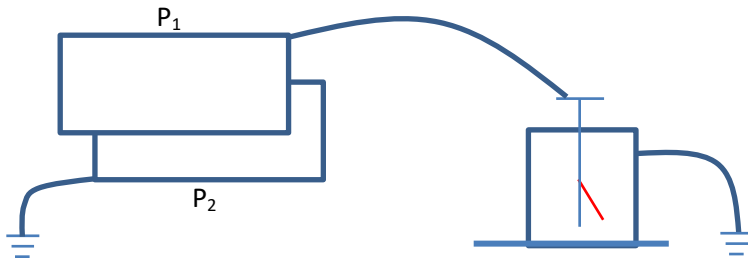

P_1 and P_2 are capacitor plates initially with air between them. P_2 is earthed while P_1 is charged and connected to the cap of electroscope. Note that for this arrangement, the charges remain constant while the p.d between the plates varies.

(a) To show that $C \propto A$

Plate P_2 is displaced sideways relative to P_1 to reduce the effective area A of the plates. The divergence of the leaf increase. This shows that the p.d. between the plates has increased since divergence is proportional to p.d between the plates. From $C = Q/V$, since Q is constant, c decreases. Thus $C \propto A$.

(d) To show that $C \propto 1/d$

Plate P_2 is restored to its initial position, and it is then moved closer to P_1 . The divergence of the leaf is seen to decrease. This shows the p.d between the plates has decreased. From $C = Q/V$, this show that C has increased. Thus C increases as d decreases. Thus $C \propto 1/d$

(e) To show that $C \propto \epsilon$

The position of P_2 is again restored and dielectric (an insulator) like paper is inserted between the plates. The divergence of the leaf decreases. This shows that V has decreased. From $C = Q/V$, C has increased. Thus $C \propto \epsilon$.

Experiment to describe the factors affecting capacitance of capacitor using a reed switch

(Factors which determine the capacitance of a capacitor using reed switch)

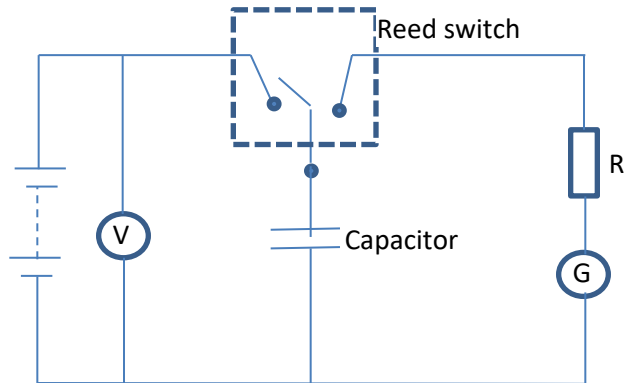

The capacitor is alternatively charged and discharged through a sensitive light beam galvanometer, G by the reed switch.

- Keeping the separation and the plate area constant, the capacitor is given a charge Q for different p.d. (V).
 - It is found that charge is proportional to V ($Q \propto V$)
- Keeping the p.d V and plate area constant, the deflection θ is measured for different separation, d .
 - Results show that charge is proportional to deflection. $C \propto 1/d$
- Keeping the p.d V and the separation constant, the deflection θ is measured for different overlapping plate area A . The results show that $C \propto A$
- Keeping the area, separation of the plates, and p.d constant; the charge is measured with a dielectric constant.
 - The results show that the charge increases, implying that C also increases. Thus $C \propto \epsilon$.

Capacitance of a parallel plate capacitor

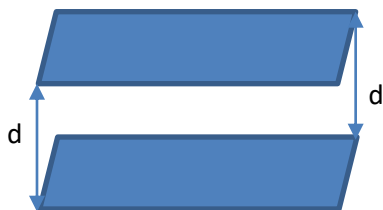

Consider a parallel-plate capacitor above, where the charge on either plate is Q and the p.d between them is V . the surface density σ is then $\frac{Q}{A}$

Wher A is the area of either plate, and the intensity between the plates, $E = \frac{\sigma}{\epsilon} = \frac{Q}{\epsilon A}$

The work done in taking a unit charge from one plate to another = force x distance
= Ed (d = the distance between the plates)

But the work per unit charge = V , the p.d between the plates.

$$\therefore V = \frac{\sigma}{\epsilon} d = \frac{Q}{\epsilon A} d$$

$$\therefore \frac{Q}{V} = \frac{\epsilon A}{d}$$

$$\therefore C = \frac{\epsilon A}{d}$$

It should be note that the formula for C is approximate, as the field becomes non-uniform at the edges

Capacitance of isolated sphere

An isolated metal sphere acts as a capacitor. The sphere itself is one plare; the earth is the other plate.

Suppose a sphere of radius r meter situated in air is give a charge of Q coulombs. We assume that the charge on a sphere gives rise to potentials on and outside the sphere as if all the charge were concentrated at the center.

Then $V = \frac{Q}{4\pi\epsilon_0 r}$

$$\therefore \frac{Q}{V} = 4\pi\epsilon_0 r$$

$$C = 4\pi\epsilon_0 r$$

Example 1

Suppose $r = 10\text{cm} = 0.1\text{m}$, then

$$C = 4\pi\epsilon_0 r = 4\pi \times 8.85 \times 10^{-12} \times 0.1 = 11 \times 10^{-12}\text{F} = 11\text{pF}$$

Capacitance of two concentric spheres

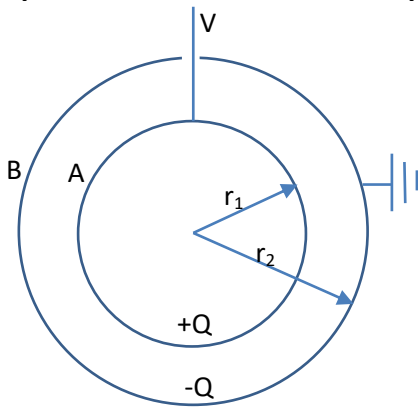

Faraday used two concentric spheres to investigate the dielectric constant of liquids. r_1 and r_2 are the respective radii of the inner and outer spheres as shown above and the outer sphere earthed, with air between them.

Let $+Q$ be the charge on the inner sphere, the induced charge on outer sphere = $-Q$.

The potential of the inner sphere = potential due to $+Q$ + potential due to $-Q$

$$\text{i.e. } V_a = \frac{+Q}{4\pi\epsilon_0 r_1} + \frac{-Q}{4\pi\epsilon_0 r_2} = \frac{Q}{4\pi\epsilon_0} \left(\frac{1}{r_1} - \frac{1}{r_2} \right)$$

since the outer sphere is earthed $V_b = 0$

$$\text{therefore the potential difference } V = V_a - V_b = \frac{Q}{4\pi\epsilon_0} \left(\frac{1}{r_1} - \frac{1}{r_2} \right) - 0 = \frac{Q}{4\pi\epsilon_0} \left(\frac{1}{r_1} - \frac{1}{r_2} \right)$$

$$\text{thus } V = \frac{Q(r_2 - r_1)}{4\pi\epsilon_0 r_1 r_2}$$

$$\text{From } C = \frac{Q}{V}, \text{ then capacitance, } C = \frac{4\pi\epsilon_0 r_1 r_2}{(r_2 - r_1)}$$

Example 2

Suppose $r_2 = 10\text{cm} = 0.1\text{m}$ and $r_1 = 9\text{cm} = 0.09\text{m}$

$$C = \frac{4\pi\epsilon_0 r_1 r_2}{(r_2 - r_1)} = \frac{4\pi \times 8.85 \times 10^{-12} \times 0.1 \times 0.09}{(0.1 - 0.09)} = 100\text{pF}$$

Relative permittivity, ϵ_r or dielectric constant

It is defined as the ratio of permittivity of a substance to the permittivity of free space

Please find free new curriculum notes, exams and marking guides on digitlteachers.co.ug website

$$\epsilon_r = \frac{\text{capacitance of a given capacitor, with space between plates filled with dielectric}}{\text{capacitance of the same capacitor in plates in vacuo}}$$

Taking the case of a parallel plate capacitor as an example, then

$$\epsilon_r = \frac{\epsilon A/d}{\epsilon_0 A/d} = \frac{\epsilon}{\epsilon_0}$$

Relative permittivity is a ratio without units.

Dielectric strength

It is the maximum potential gradient that can be applied to a dielectric material without causing its insulation to break down.

Or

It is the potential gradient at which insulation of dielectric breaks down and spark passes through it.

Note: once the insulation of dielectric breaks down, it becomes a conductor and the capacitor becomes useless since it can no longer store charge.

Effect of dielectric between the plates of a charged capacitor

Introducing a **dielectric** into a capacitor decreases the electric field, which decreases the voltage, which increases the capacitance. A capacitor with a **dielectric** stores the same charge as one without a **dielectric**, but at a lower voltage. Therefore a capacitor with a **dielectric** in it is more effective.

Dielectric, insulating material or a very poor conductor of electric current. When dielectrics are placed in an electric field, practically no current flows in them because, unlike metals, they have no loosely bound, or free, electrons that may drift through the material.

Instead, electric polarization occurs. The positive charges within the dielectric are displaced minutely in the direction of the electric field, and the negative charges are displaced minutely in the direction opposite to the electric field as shown in the figure below. This slight separation of charge, or polarization, reduces the electric field within the dielectric.

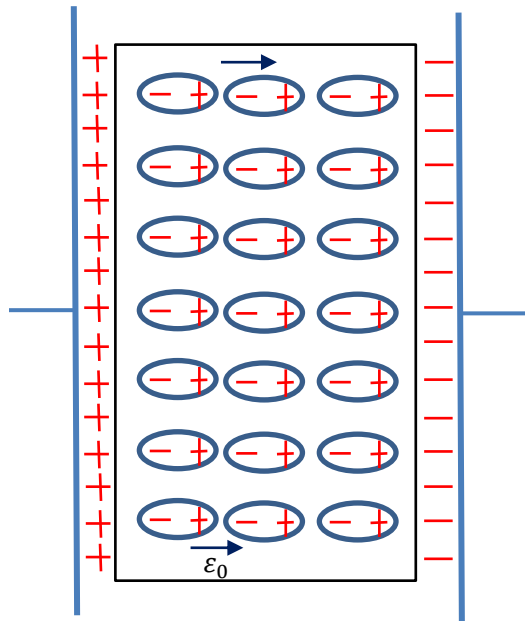

ϵ_0 and its measurement

Units of ϵ_0

$$\text{From } C = \frac{\epsilon_0 A}{d}; \epsilon_0 = \frac{Cd}{A}$$

Thus, the units of $\epsilon_0 = \frac{\text{farad} \times \text{meter}}{\text{meter}^2} = \text{faradmeter}^{-1}$

Measurement of ϵ_0

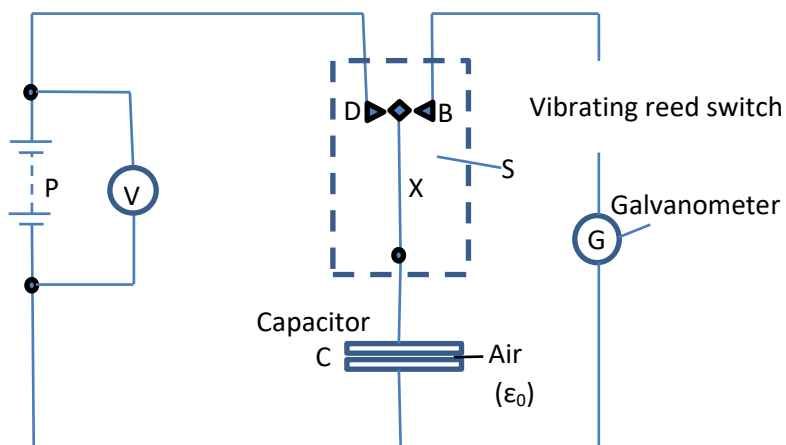

The circuit above is used.

Please find free new curriculum notes, exams and marking guides on digitteachers.co.ug website

C is a parallel capacitor with area A (m²) and separation, d (m)

P is a high tension of about 200V,

G is a sensitive galvanometer,

S is a vibrating switch unit, energized by a low a.c. voltage from the mains.

When operating, the vibrating bar X touches D and then B, and the motion is repeated at the mains frequency, fifty times a second.

When the switch is in contact with D, the capacitor is charged from the supply P to a potential difference of V volts, measured on a voltmeter.

When the contact moves over to B, the capacitor discharges through the galvanometer. The galvanometer thus receives fifty pulse of charge per second.

This gives an average steady current I

From $C = \epsilon_0 A/d$

On charging the charge stored, $Q = CV = \frac{\epsilon_0 VA}{d}$

The capacitor is discharged fifty times per second. And since current is the charge flowing per second

$$I = \frac{\epsilon_0 VA \cdot 50}{d} \text{ ampere}$$

$$\epsilon_0 = \frac{Id}{50VA} \text{ farad meter}^{-1}$$

The following results were obtained in one experiment

$A = 0.0317\text{m}^2$, $d = 1.0\text{cm} = 0.02\text{m}$, $V = 150\text{V}$, $I = 0.21 \times 10^{-6}\text{A}$

$$\epsilon_0 = \frac{Id}{50VA} = \frac{0.21 \times 10^{-6} \times 0.01}{50 \times 150 \times 0.0317} = 8.8 \times 10^{-12} \text{ farad meter}^{-1}$$

This method can also be used to find the permittivity of various material. Thus if the experiment is repeated with a material of permittivity ϵ completely filling the space between the plates, then

$$\epsilon = \frac{I'd}{50VA} \text{ where } I' \text{ is the new current}$$

If only the relative permittivity or dielectric constant ϵ_r is required, there will be no need to know p.d or dimension of the capacitor. In this case

$$\epsilon_r = \frac{\epsilon}{\epsilon_0} = \frac{I'd/50VA}{Id/50VA} = \frac{I'}{I}$$

Please find free new curriculum notes, exams and marking guides on digitlteachers.co.ug website

Thus ϵ_r is the ratio of respective currents in G with and without the dielectric between plates.

Arrangement of capacitors

(a) Parallel connection

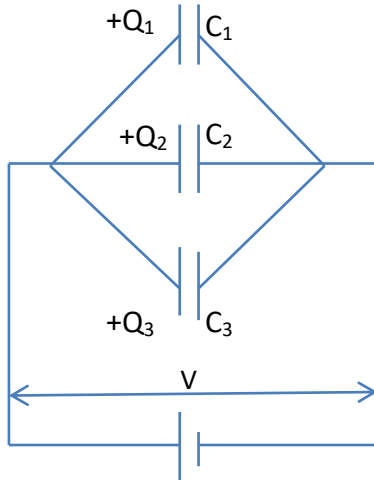

In parallel each capacitor experiences the same p.d.

For charged capacitor, $Q = CV$

Therefore, $Q_1 = C_1V$; $Q_2 = C_2V$; $Q_3 = C_3V$;

The total charge, $Q = Q_1 + Q_2 + Q_3 = C_1V + C_2V + C_3V = V(C_1 + C_2 + C_3)$

If C is the capacitance of a single capacitor which has the same effect as these three capacitors store charge equal to Q then,

$$Q = CV = V(C_1 + C_2 + C_3)$$

$$C = \frac{Q}{V} = (C_1 + C_2 + C_3)$$

$$C = (C_1 + C_2 + C_3)$$

Therefore for capacitors in parallel, the total capacitance is the sum of individual capacitances of individual capacitor.

(b) Series connection

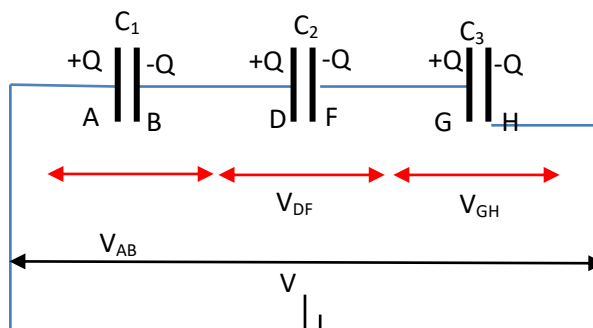

Please find free new curriculum notes, exams and marking guides on digitlteachers.co.ug website

On connection, the battery draws electrons from plate A and leaves it with a positive charge +Q. this induces a charge -Q on B. A and D form an isolated conductor and the charge that appears on B results from electrons moving from D to B. D is left with charge +Q and this induces a charge -Q on F, and so on.

The p.d across each capacitor is given by

$$V_{AB} = \frac{Q}{C_1}; V_{DF} = \frac{Q}{C_2}; V_{GH} = \frac{Q}{C_2};$$

Total voltage, $V = V_{AB} + V_{DF} + V_{GH}$

$$\frac{Q}{C} = Q\left(\frac{1}{C_1} + \frac{1}{C_2} + \frac{1}{C_3}\right)$$

From which $\frac{1}{C} = \left(\frac{1}{C_1} + \frac{1}{C_2} + \frac{1}{C_3}\right)$

Comparison of capacitors and resistor in network

	Capacitors in network	Resistors in network
Series connection	$\frac{1}{C} = \left(\frac{1}{C_1} + \frac{1}{C_2} + \frac{1}{C_3}\right)$	$R = (R_1 + R_2 + R_3)$
Parallel connection	$C = (C_1 + C_2 + C_3)$	$\frac{1}{R} = \left(\frac{1}{R_1} + \frac{1}{R_2} + \frac{1}{R_3}\right)$

Example 3

In the figure below, two capacitors of capacitances, C_1 and C_2 of $3\mu\text{F}$ and $6\mu\text{F}$ respectively are connected across a 90V d.c. calculate the charge on C_1 and C_2 , and the p.d across each.

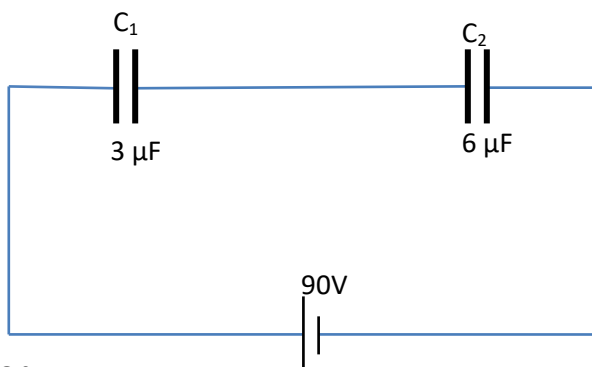

Solution

The effective capacitance, c is obtained from

$$\frac{1}{C} = \left(\frac{1}{C_1} + \frac{1}{C_2}\right) = \frac{1}{3} + \frac{1}{6}$$

$$C = 2\mu\text{F}$$

$$Q = CV = 2 \times 10^{-6} \times 90 = 1.8 \times 10^{-4} \text{ C}$$

$$\text{For } C_1; V_1 = \frac{Q}{C_1} = \frac{1.8 \times 10^{-4}}{3 \times 10^{-6}} = 60\text{V and.}$$

$$\text{For } C_2; V_2 = \frac{Q}{C_1} = \frac{1.8 \times 10^{-4}}{6 \times 10^{-6}} = 30\text{V}$$

Example 4

Calculate the charge on the capacitors below and the p.d across each.

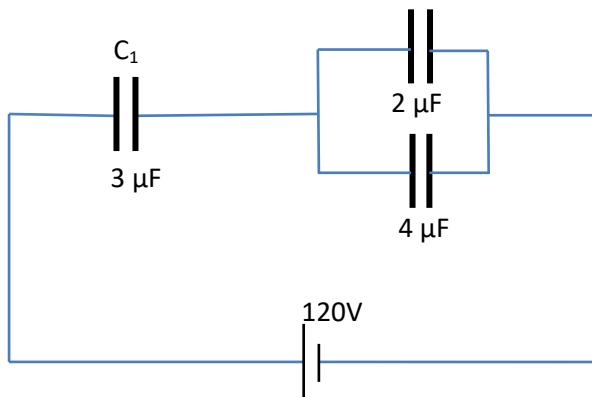

Solution

The effective capacitance, C_1 for parallel capacitors $2\mu\text{F}$ and $4\mu\text{F} = 2 + 4 = 6\mu\text{F}$.

Now $3\mu\text{F}$ and $6\mu\text{F}$ are in series and their effective capacitance C is given by

$$\frac{1}{c} = \frac{1}{3} + \frac{1}{6}$$

$$C = 2\mu\text{F}$$

$$\text{For the whole circuit, } Q = CV = 2 \times 10^{-6} \times 120 = 2.4 \times 10^{-4} \text{C}$$

$$\text{The charge } 3\mu\text{F capacitor} = 2.4 \times 10^{-4} \text{C}$$

$$\text{The p.d across the } 3\mu\text{F capacitor} = \frac{2.4 \times 10^{-4}}{3 \times 10^{-6}} = 80\text{V}$$

$$\text{The p.d across each either } 2\mu\text{F or } 4\mu\text{F} = 120 - 80 = 40\text{V}$$

From $Q = CV$

$$\text{The charge on } 2\mu\text{F capacitor} = 40 \times 2 \times 10^{-6} = 8 \times 10^{-5} \text{ C}$$

$$\text{Charge on } 4\mu\text{F capacitor} = 40 \times 4 \times 10^{-6} = 1.6 \times 10^{-4} \text{ C}$$

Energy stored in a charged capacitor

A charged capacitor stores electrical energy. To find the energy stored, we assume that a capacitor of capacitance C is already charged to a potential difference V .

When the charge on the plates is increased from Q to $Q + \delta Q$ where δQ is very small, then a charge δQ is transferred from the negative to the positive plate.

The increase in potential difference $\delta V = \frac{\delta Q}{C}$

Since δQ is very small compared with Q , δV will be very small compared to V and the potential difference will be almost constant at value V .

Then the work done, δW , in displacing the charge δQ is given by

$$\delta W = V\delta Q$$

$$\text{Since } V = \frac{Q}{C}; \delta W = \frac{Q}{C}\delta Q$$

For a fully discharged capacitor charged to a value Q_1 , work done is given by

$$\int_{Q=0}^{Q=Q_1} \delta W = \int_0^{Q_1} \frac{Q}{C} \delta Q = \left[\frac{1}{2} \frac{Q^2}{C} \right]_0^{Q_1} = \frac{Q^2}{2C}$$

In general, the energy stored by a capacitor of capacitance C , carrying a charge Q at a potential difference V is

$$W = \frac{Q^2}{2C} = \frac{1}{2} QV$$

$$= \frac{1}{2} CV^2$$

If C is in farad, Q in coulomb and V in volt, then W is in joules.

Joining two charged capacitors

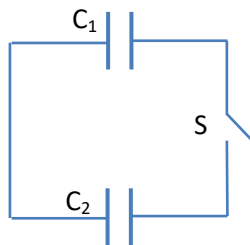

When two capacitors are joined together by means of switch S , charge flows from one capacitor with greater p.d to the other until the p.d across each is the same.

The final p.d and energy of each can be calculated by considering the following

Please find free new curriculum notes, exams and marking guides on [digitlteachers.co.uk](https://www.digitlteachers.co.uk) website

- There is no change in the total charge
- Two capacitors acquire the same p.d
- Capacitors are considered to be in parallel and therefore the effective capacitance of the combination, $C = C_1 + C_2$

Note that the final energy stored by the capacitors is less than the initial energy before the capacitors are joined together. This is because some energy is dissipated as heat in the connecting wires when the charge flows from one capacitor to another.

Example 5

A $5\mu\text{F}$ capacitor X is charged by a 40V supply and then connected across an uncharged $20\mu\text{F}$ capacitor Y. Calculate

- Final p.d across each
- Final charge on each, and
- Initial and final energies stored by the capacitors.

Solution

The initial charge, $Q_0 = CV = 5 \times 10^{-6} \times 40 = 2 \times 10^{-4}\text{C}$

After connection

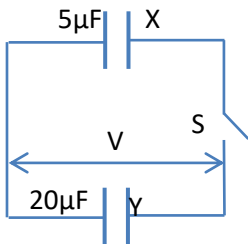

Since the capacitors are in parallel, the effective capacitance, $C = C_1 + C_2 = 5 + 20 = 25\mu\text{F}$

Initial charge = final charge

Let V be the final voltage, then

$$2.0 \times 10^{-4} = 25 \times 10^{-6}V$$

$$V = 8\text{V}$$

$$\text{(b) charge on } 5\mu\text{F capacitor} = CV = 5 \times 10^{-6} \times 8 = 4.0 \times 10^{-5}\text{C}$$

$$\text{Charge of } 20\mu\text{F capacitor} = CV = 20 \times 10^{-6} \times 8 = 1.6 \times 10^{-4}\text{C}$$

$$\text{(c) from } W = \frac{1}{2} CV^2$$

$$\text{Initial energy} = \frac{1}{2} \times 5 \times 10^{-6} \times 40^2 = 0.004\text{J}$$

$$\text{Final energy} = \frac{1}{2} \times 25 \times 10^{-6} \times 8^2 = 0.0008\text{J}$$

The final energy is less than the initial energy because some energy is lost as heat due to flow of charge from 5 μ F to 20 μ F

Example 6

Two parallel capacitors, one with air as dielectric and the other with mica as dielectric, are identical in all other respect. The air capacitor is charged from 400V d.c supply, isolated and then connected across the mica capacitor which is initially uncharged.

The p.d across this parallel combination becomes 50V. Assuming the relative permittivity of air to be 1.00, calculate the relative permittivity of mica.

Solution

Let C_a = capacitance of the air capacitor, C_m = capacitance of mica capacitor

Charge stored by air capacitor, $Q_a = C_a V = 400C_a$ (i)

For air $= \frac{C_a}{C_0} = 1$, where C_0 = capacitance of free space or vacuum.

Then, $C_a = C_0$ and,

$$Q_a = 400C_0$$

Charge store in mica capacitor before connection = 0

Therefore total initial charge = $400C_0 + 0 = 400C_0$(ii)

After connection

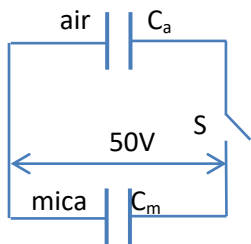

Total charge before = total charge after

$$400C_0 = 50(C_a + C_m)$$

Since $C_a = C_0$

$$400C_0 = 50(C_0 + C_m)$$

$$7C_0 = C_m$$

Please find free new curriculum notes, exams and marking guides on digitlteachers.co.ug website

$$\frac{C_m}{C_0} = 7$$

Therefore relative permittivity of mica = 7

Example 7

- Define a capacitance of a capacitor.
- Explain how, using a capacitor in conjunction with a gold-leaf electroscope, the voltage sensitivity of electroscope may be increased.
- Two capacitors, of capacitance $4\mu\text{F}$ and $2\mu\text{F}$ respectively are joined in series with a battery of e.m.f 100volts. The connections are broken and the terminals of the capacitors are then joined. Find the final charge on each capacitor.

Solution

The combined capacitance, C, of capacitors is given by

$$\frac{1}{C} = \frac{1}{C_1} + \frac{1}{C_2} = \frac{1}{4} + \frac{1}{2} = \frac{3}{4}$$

$$C = \frac{4}{3} \mu\text{F}$$

The charge on each capacitor = charge on the effective capacitance

$$= CV = \frac{4}{3} \times 10^{-6} \times 100 = \frac{400}{3} \times 10^{-6} \text{coulomb}$$

When like terminals are joined together, the p.d across each capacitor, which is different at first, becomes equilized. Suppose it reaches a p.d V, as the total charge remains constant.

$$\text{Initial total charge} = \left(\frac{400}{3} + \frac{400}{3}\right) \times 10^{-6} = \text{final charge total charge} = 4 \times 10^{-6}V + 2 \times 10^{-6}V$$

$$4 \times 10^{-6}V + 2 \times 10^{-6}V = \frac{800}{3} \times 10^{-6}$$

$$V = \frac{400}{9} \text{ volts,}$$

$$\text{Therefore, the charge on } 4\mu\text{F capacitor} = CV = 4 \times 10^{-6} \times \frac{400}{9} = 1.78 \times 10^{-4}\text{C}$$

$$\text{The charge on } 2\mu\text{F capacitor} = CV = 2 \times 10^{-6} \times \frac{400}{9} = 8.89 \times 10^{-5}\text{C}$$

Example 8

- (a) Define the electrostatic potential of an isolated conductor.
- (b) Obtain an expression relating the energy of a charged conductor to the charge on it and its capacitance
- (c) Two insulated spherical conductors of radii 5.00cm and 10.00cm are charged to potentials of 600volts and 300 volts respectively. Calculate
- the total energy of the system.
 - The energy after the spheres have been connected by a fine wire.
 - Comment on the difference between the two results in C(i) and C(ii).

Solution

(a) The electrostatic potential of an isolated conductor is work done to move a unit positive charge from infinity to a point in an electric field of the conductor.

(b) Refer to the notes

(c) (i) Capacitance C of a sphere of radius $r = 4\pi\epsilon_0 r$

$$\text{For } 5\text{cm} = 0.05\text{m radius, } C_1 = 4\pi\epsilon_0 \times 0.05 = \frac{0.05}{9 \times 10^9} = \frac{5}{9} \times 10^{-11} F$$

$$\text{Since } 4\pi\epsilon_0 = \frac{1}{9 \times 10^9}$$

$$\text{For } 10\text{cm} = 0.1\text{m radius, } C_2 = 4\pi\epsilon_0 \times 0.1 = \frac{0.1}{9 \times 10^9} = \frac{10}{9} \times 10^{-11} F$$

$$\text{But work} = \frac{1}{2} C V^2$$

$$\text{Total energy} = \frac{1}{2} \times \frac{5}{9} \times 10^{-11} \times 600^2 + \frac{1}{2} \times \frac{10}{9} \times 10^{-11} \times 300^2 = 1.5 \times 10^{-6} \text{J}$$

(ii) when the spheres are connected by a fine wire, the potentials become equalized

Let V be the common voltage, since $Q = CV$ and the total charge is constant

Original total charge = total final charge

$$4\pi\epsilon_0(5 \times 10^{-2} \times 600 + 10 \times 10^{-2} \times 300) = (5 \times 10^{-2}V + 10 \times 10^{-2}V)$$

$$V = 400\text{volts}$$

$$\text{Total final energy} = \frac{1}{2} C_1 V^2 + \frac{1}{2} C_2 V^2$$

$$= \frac{1}{2} (C_1 + C_2) V^2$$

$$= \frac{1}{2} \times \frac{1}{9 \times 10^9} (5 \times 10^{-2} + 10 \times 10^{-2}) \times 400^2$$

$$= 13.33\text{J}$$

(iii) When spheres are connected stored energy is less because part of energy is converted into heat because current flows to equalize.

Example 9

- (a) Define electrical capacitance.
- (b) Describe experiments to demonstrate the factors which determine its value for parallel plate capacitance

- (c) The plates of a parallel plate air capacitor consisting of two circular plates each of radius 10cm and laced 2mm apart, are connected to terminals of an electrostatic voltmeter. The system is charged to give a reading of 100 on the voltmeter scale. The space between the plates is then filled with oil of dielectric constant 4.7 and the voltmeter reading falls to 25. Calculate the capacitance of the voltmeter. You may assume that the voltage recorded by voltmeter is proportional to the scale reading.

Solution

Let V be the initial p.d across the air capacitor, and C1 be the voltmeter capacitance.

Then total charge = CV + C₁V = (C + C₁)V(i)

When the plates are filled with oil the capacitance increases to 4.7C, and the p.d falls to V₁.

But the total charge remains constant.

From (i)

$$4.7CV_1 + C_1V_1 = (C + C_1)V$$

$$(4.7C + C_1)V_1 = (C + C_1)V$$

$$\frac{4.7C + C_1}{C + C_1} = \frac{V}{V_1} = \frac{100}{25} = 4$$

$$0.7 C = 3C_1$$

$$C_1 = \frac{0.7C}{3} = \frac{7}{30}C$$

But C = ε₀A/d, where A in meter² and d in meter

$$C = \frac{8.85 \times 10^{-12} \times \pi \times (10 \times 10^{-2})^2}{2 \times 10^{-3}} = 1.4 \times 10^{-10} \text{ F}$$

$$C_1 = \frac{7}{30} \times 1.4 \times 10^{-10} = 3.3 \times 10^{-11} \text{ F}$$

Discharging a capacitor through a resistor.

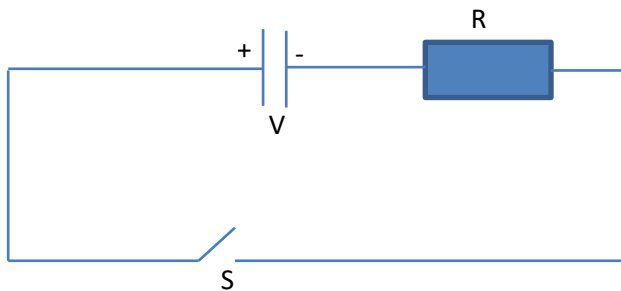

When switch, S is closed, the resistance R limits the current flow and discharge is not instantaneous which makes the capacitor to discharge slowly. This

Determining capacitance of a capacitor using a reed switch

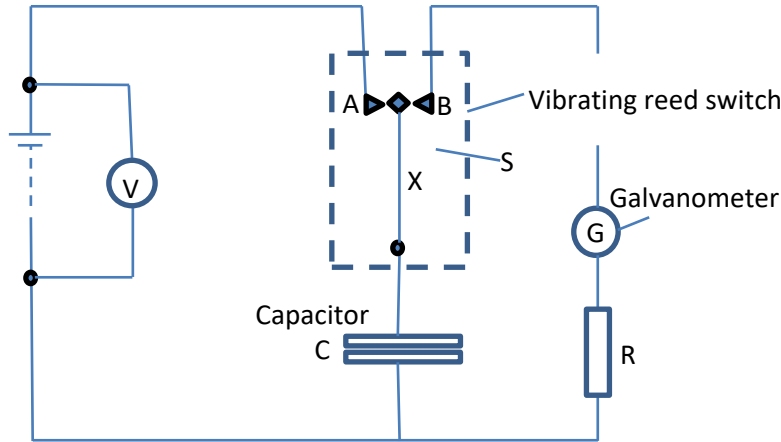

- The circuit is connected as shown above.
- The capacitor is discharged by connecting the contact of the vibrating reed switch X with A.
- The p.d across the capacitor plates is recorded as V from the voltmeter.
- When the contact of the reed switch is to B, the capacitor discharges rapidly and the current I flows through galvanometer is noted
- If the frequency of the vibrating switch is f;
 $I = \text{charge per second} = fQ \dots\dots\dots (i)$

But $Q = CV$

Eqn (i) becomes $I = fCV$

$$C = \frac{I}{fV}$$

Hence the capacitance of the capacitor can be determined.

Main Uses of Capacitors

(i) Energy Storage

- o Store electrical energy and release it when needed (like a temporary battery).
- o Used in camera flashes and defibrillators for quick energy discharge.

(ii) Filtering & Signal Processing

- o Smooth out voltage fluctuations in power supplies (filtering ripples in rectifiers).
- o Separate AC signals from DC in circuits (coupling and decoupling capacitors).

(iii) Timing & Oscillators

- o In combination with resistors, capacitors set timing intervals in circuits (RC circuits).

- Used in oscillators to generate signals for radios, clocks, and communication devices.
- (iv) **Power Factor Correction**
 - Improve efficiency in AC power systems by compensating for lagging current.
 - Widely used in industrial electrical systems.
- (v) **Motor Starters**
 - Provide the phase shift needed to start single-phase induction motors (like in fans, pumps, washing machines).
- (vi) **Tuning Circuits**
 - Adjust frequency response in radios, TVs, and communication equipment.
 - Variable capacitors help tune to different stations.
- (vii) **Energy Pulses**
 - Deliver short bursts of energy in applications like welding, particle accelerators, and medical equipment.
- (viii) **Memory Storage**
 - Dynamic RAM (DRAM) in computers uses tiny capacitors to store bits of information.

Everyday Examples

- **Electronics:** Smartphones, laptops, TVs, radios.
- **Appliances:** Refrigerators, washing machines, fans.
- **Medical Devices:** Defibrillators, X-ray machines.
- **Industrial Systems:** Power grids, motor drives, welding equipment.

Revision exercise

1. A $10.0\mu\text{F}$ capacitor charged to 200V is connected across an uncharged $50\mu\text{F}$ capacitor. Calculate the total energy stored in both capacitors before and after connection (**Ans. 0.2J, 0.033J**)
2. A $2.5\mu\text{F}$ capacitor is charged to a p.d of 100V and is disconnected from the supply. Its terminals are then connected to those of an uncharged $10\mu\text{F}$ capacitor. Calculate the
 - (a) Resulting p.d across the two capacitors. (**Ans. 20V**)
 - (b) Initial and final total energy stored in them (**0.0125J, 0.0025J**)
3. Three capacitors of capacitances $4.0\mu\text{F}$, $6.0\mu\text{F}$ and $12.0\mu\text{F}$ are connected in series across a 6V d.c supply. Calculate
 - (a) The charge on $12.0\mu\text{F}$ capacitor
 - (b) Total energy stored in the capacitors
 - (c) P.d across the $4.0\mu\text{F}$ capacitor

[(a) $12 \times 10^{-6}\text{C}$, (b) $3.6 \times 10^{-5}\text{J}$, (c) 3.0V]
4. The capacitance of variable radio capacitor can be varied continuously from 25pF to 500pF by turning the dial from 0° to 180° . With the dial set at 180° , the capacitor is

connected to a 600V battery. After charging, the capacitor is disconnected from the battery and then the dial is turned to 0° . Calculate the

(a) Charge on the capacitor'

(b) Energy stored in the capacitor,

(c) The work required to turn the dial from 180° if friction is neglected.

[ans. (a) $3.0 \times 10^{-7}\text{C}$, (b) $9.0 \times 10^{-5}\text{J}$, (c) $1.71 \times 10^{-3}\text{J}$]

**Thank you
Dr. Bbosa Science**