



*Dr. Blossa Science*

Sponsored by  
**The Science Foundation College**  
**Uganda East Africa**  
Senior one to senior six  
**+256 778 633 682, 753 802709**  
**Based On, best for science**

[digitalteachers.co.ug](http://digitalteachers.co.ug)



 Nurture your dreams 

**UACE P515/2 Principles and practices of agriculture2 2004**

**3hours**

**Instructions**

- This paper consists of sections: **A, B, C, D and E**
- Answer **question 1** in section A and four other questions, selecting **one** from each of the sections **C, D and E**.
- Write your answers in the answer booklets provided
- Any additional question(s) answered will not be marked

SECTION A (20MARKS)

Question1 is compulsory

1. In breeds of sheep kept under the same environment conditions, intact males show higher concentration of somatotrophin hormone in their blood than either female or castrated males. Somatotrophin hormone is produced by the anterior lobe of the pituitary gland and affects growth rate and ability to lay down fat in sheep.  
In an investigation into action of somatotrophin, a group of lambs received a daily injection of the hormone. Figure 1 shows the effect of the hormone on food conversion efficiency, growth and carcass composition in relation to a control group of lambs

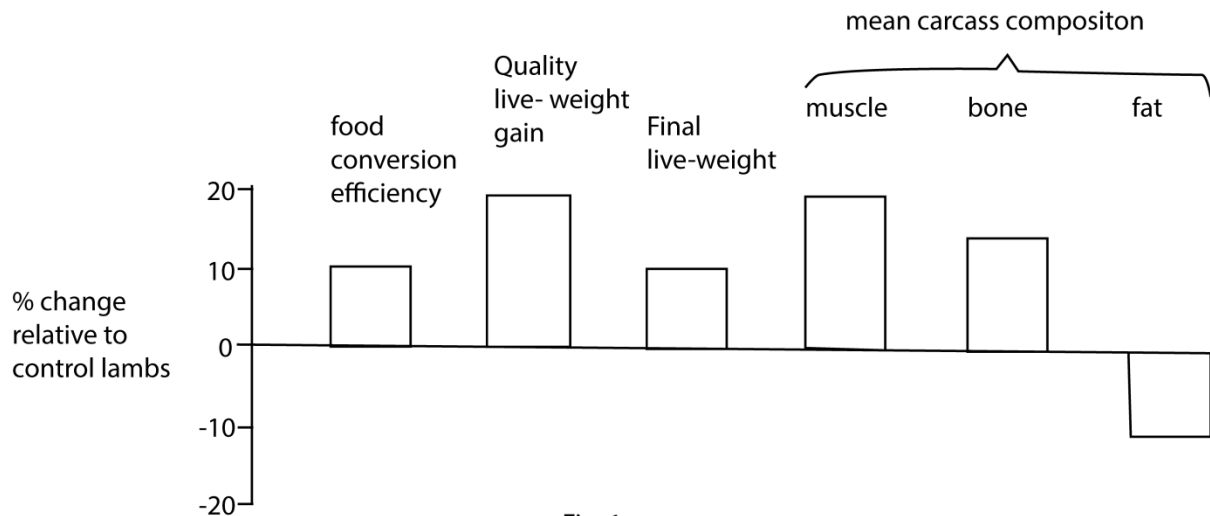

Fig. 1

- (a) What is meant by control group of lamb?(03marks)
- (b) (i) With reference to Figure 1. Summarize the commercial advantages using somatotrophin. (05marks)
- (ii) Suggest one long term disadvantage of somatotrophin use. (01mark)
- (c) Explain why intact males have greater bone and muscle growth (03marks)
- (d) Somatotrophin exerts its effect by controlling the rate at which tissue can mobilize nutrient from food. Giving reasons, suggest which nutrients are likely to be mobilized from the blood under the influence of somatotrophin. (04marks)
- (e) Explain why the somatotrophin was administered to the lamb by injection. (04 marks)

## SECTION B (20 MARKS)

### CROP PRODUCTION

2. (a) What are the causes of low soil productivity (05marks)
- (b) Explain how soil productivity could be improved. (15marks)
3. (a) Outline the economic importance of bananas. (05marks)
- (b) Describe how you would maintain a banana plantation to ensure high production. (15marks)

**SECTION C (20 MARKS)**

**ANIMAL PRODUCTION**

- 4 (a) Outline the objectives of livestock breeding. (06marks)
- (b) Describe each of the following methods of livestock breeding and in each case give the importance of the method.
- (i) inbreeding (3½ marks)
  - (ii) cross breeding (3½ marks)
  - (iii) grading-up (3½ marks)
  - (iv) outbreeding (3½ marks)
- 5 (a) Give reasons for popularity of the deep litter system among Uganda commercial poultry farmer (12marks)
- (b) Describe the management practices carried out in deep litter house to ensure high egg production. (08 marks)

**SECTION D (20 MARKS)**

**AGRICULTURAL MECHANIZATION**

6. (a) Discuss the precautions to be taken while using chemicals on a farm. (14marks)
- (b) Outline the maintenance practices on sprayer (06marks)
7. (a) Describe the components of a mechanical planter. (15marks)
- (b) What are advantages of using mechanical planter (05marks)

**SECTION e (20 MARKS)**

**AGRICULTURAL ECONOMICS**

8. (a) Describe the types of production functions experienced in farming (12marks)
- (b) Explain how the production function can be used to determine the most profitable levels of production. (08marks)
9. (a) Explain why agricultural co-operatives in Uganda have not been successful?(12marks)
- (b) What would be the benefits of successful agricultural co-operatives in Uganda? (08marks)

**Suggested answers**

1. In breeds of sheep kept under the same environment conditions, intact males show higher concentration of somatotrophin hormone in their blood than either female or castrated males. Somatotrophin hormone is produced by the anterior lobe of the pituitary gland and affects growth rate and ability to lay down fat in sheep.
- In an investigation into action of somatotrophin, a group of lambs received a daily injection of the hormone. Figure 1 shows the effect of the hormone on food conversion efficiency, growth and carcass composition in relation to a control group of lambs

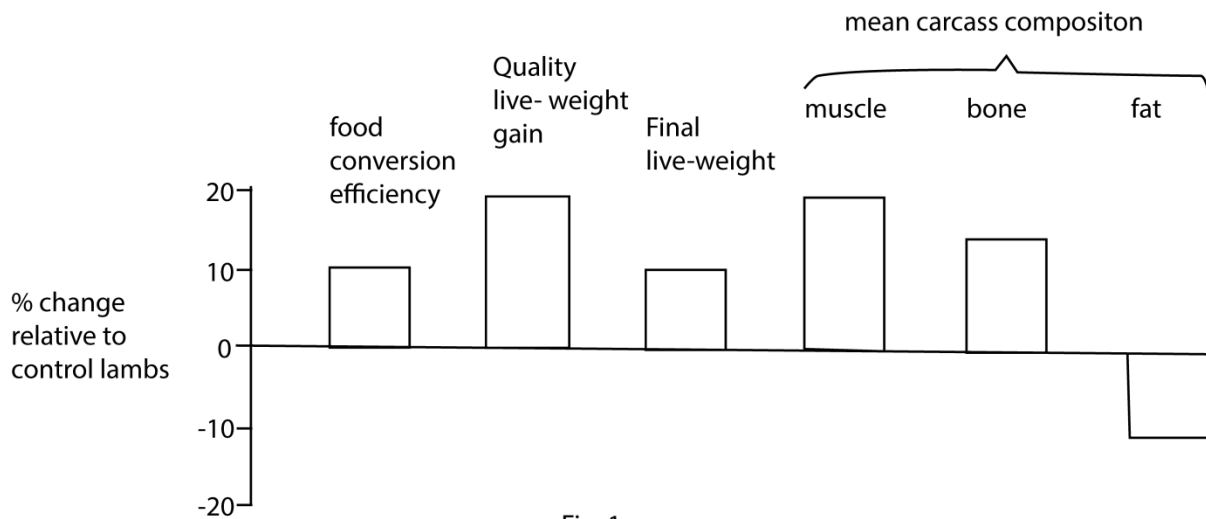

Fig. 1

- (a) What is meant by control group of lambs?(03marks)
- These are the same group of lambs that did not receive somatotrophin treatment; they have the same age, breed, sex etc.; they are used as reference experiment.

(b) (i) With reference to Figure 1. Summarize the commercial advantages using somatotrophin.

(05marks)

- Better food conversion efficiency (10%)
- Better daily live weight gain (20%)
- Better final live weight gain (10%)
- More muscle by 15%
- More bone by 10%
- Less fat by 10%

(ii) Suggest one long term disadvantage of somatotrophin use. (01mark)

- A lot of bones will be produced
- Low fat production

(c) Explain why intact males have greater bone and muscle growth (03marks)

- Have high level of somatotrophin that promote bone and muscle development

(d) Somatotrophin exerts its effect by controlling the rate at which tissue can mobilize nutrient from food. Giving reasons, suggest which nutrients are likely to be mobilized from the blood under the influence of somatotrophin. (04marks)

- Amino acids for muscle growth
- Calcium and phosphate for bone and muscle development
- Glucose to provide energy through respiration
- Fatty acids for cell wall development

(e) Explain why the somatotrophin was administered to the lamb by injection. (04 marks)

- To prevent destruction in the digestive system
- Accurate dosing
- Faster action

## **SECTION B (20 MARKS)**

### **CROP PRODUCTION**

2. (a) What are the causes of low soil productivity (05marks)

- Soil erosion leads to loss of crop nutrients
- Leaching leads to inaccessibility of soil nutrients
- Poor drainage may lead to water logging and hence poor soil aeration and unfavorable soil temperature.
- Poor tillage destroys soil structure leading to leaching
- Unfavorable pH

- Soil capping i.e. development of impervious layer on the soil surface
- Development of hard pans or impervious layers below the soil surface
- Lack of required soil nutrients
- Presence of pests and disease causing organisms in the soil
- Presence of weeds which compete with plants for nutrients
- Lack of adequate soil moisture.
- Mono-cropping cause soil exhaustion and buildup disease causing organisms
- Burning of vegetation destroys soil living organisms
- Excessive irrigation cause leaching
- Excessive drainage lead to loss nutrients
- Salinity of the soil

(b) Explain how soil productivity could be improved. (15marks)

- Through application of manure and fertilizers
- Practicing crop rotation to promote usage of different nutrients
- Irrigation to provide water in the soil.
- Drainage of excess water
- Modifying soil pH
- Draining excess water from water logged soil
- Mulching to maintain soil moisture
- Controlled grazing
- Prevention of soil erosion
- Control pests and diseases
- Proper cropping like preventing overcrowding
- Applying effective method of water conservation

3. (a) Outline the economic importance of bananas. (05marks)

- It is used as staple food in Uganda
- Used as fruits
- Source revenue to farmers
- Source of revenue to government
- Used for making alcohols
- Fibres are used for mats and baskets
- For making sweet juice

(b) Describe how you would maintain a banana plantation to ensure high production. (15marks)

- Weeding to reduce competition
- Mulching to maintain soil water and fertility
- Application of manure to improve soil nutrients

- Application of pesticides to kill pest such as weevils
- Pruning to reduce unnecessary plants and increase yield of the remaining plant
- Irrigation to combat water stress
- Providing extra support to banana trees with heavy bunches
- Remove dead leaves to promote light penetration, minimize pest
- Harvesting mature bunches before ripening
- Removal of male inflorescences to reduce bunch weight and reserve nutrients to growing bananas.

### **SECTION C (20 MARKS)**

#### **ANIMAL PRODUCTION**

4 (a) Outline the objectives of livestock breeding. (06marks)

- To maintain desirable qualities in animals like increased number of eggs produced in chicken, high number of off springs born per animal,
- Produce animals with a high mothering ability i.e. low temperament and high milk production
- Produce highly fertile animals that can produce twins or many offspring
- Produce animals with a high growth rate
- Produce animals that can give a lot products like milk and eggs
- To come up with breeds that produce high quality meat, wool, milk and egg
- To produce breeds of animals that are resistant to parasites and diseases
- Produce animals with high feed conversion ratio.
- To produce animals with a high resistance to harsh environmental conditions
- To produce animals that can provide products for a long period of time

(b) Describe each of the following methods of livestock breeding and in each case give the importance of the method.

(i) inbreeding (3½ marks)

- Inbreeding is the mating of close relatives e.g. brother and sister
- Inbreeding increases the similarities between animal herd
- It is used to produce pure lines which can be used in future breeding
- Increases prevalence of undesirable genes

(ii) cross breeding (3½ marks)

- It is mating of animas belonging to different pure breeds
- Introduces high breed vigor in offspring
- It is often used to upgrade local breeds

(iii) grading-up (3½ marks)

- This is the mating of pure breed sire/bulls with lower grade female animals in order to improve the quality of herd.
- It is used in improving indigenous stock

(iv) out breeding (3½ marks)

- This is mating of unrelated animals within the same breed
- It increases heterozygosity and make the herd more stable in performance
- Leads to increased hybrid vigour and therefore better performing offspring

5 (a) Give reasons for popularity of the deep litter system among Uganda commercial poultry farmer (12marks)

- It requires a small area of land to raise large number of birds.
- It's easy to control birds since they are confined in one place
- Birds are protected from predators and thieves.
- It gives comfort to both attendant and the birds since there is little wastage energy and time in feeding and collection of eggs.
- Birds are protected from bad weather
- Manure obtained under this system is of high quality
- Easy to identify and cull unproductive birds
- Records of stock and egg production are easy to keep under this system.
- It's easy to observe sick birds in the flock hence easy to cull out such birds.
- Spread of disease from the neighborhood is easily controlled since birds are confined.

(b) Describe the management practices carried out in deep litter house to ensure high egg production. (08 marks)

- Provide enough space in the house to control overcrowding that result into vices and disease outbreak
- Keep the litter dry by continuous raking and removal of wet spots to control dampness that encourages disease outbreak
- Provide enough perches for the birds and they should be well spaced
- Provide enough water and feed troughs to reduce overcrowding at the feeding and drinking place which increase feed and water contamination
- Provide clean drinking water at all times for proper bird health and high production
- Keep feeders and drinkers clean to reduce disease outbreaks due unhygienic conditions
- Provide adequate feeds to birds to maintain a high production level
- Collect the eggs regularly to reduce chances of breaking and occurrence of egg eating vice
- Supply grit in feeds to help birds to digest grains in the feeds provided
- Cull poor layers and diseased birds to reduce wastage of feeds and disease spread in poultry

- Vaccinate birds against killer diseases in time to reduce losses
- Spray birds with pesticides to control external parasites like mites and ticks that may lower production
- Avoid stressing factors that may affect bird production
- Repair equipment and house to reduce accidents
- Provide enough feeds to ensure high production from birds
- Isolate and treat sick birds to reduce disease spread in poultry
- Keep proper records for easy management of poultry
- Promptly dispose of dead birds by burying or burning to reduce disease spread and vices
- Maintain a disinfectant at the door for anybody entering the poultry house to disinfect him.

### **SECTION D (20 MARKS)**

#### **AGRICULTURAL MECHANIZATION**

6. (a) Discuss the precautions to be taken while using chemicals on a farm. (14marks)

- Read the instructions on the container or leaflet before using the pesticide
- Use recommended doses of chemicals
- Store chemical in safe places away from reach of children
- Store chemicals at low temperature to minimize deterioration.
- Wear protective clothes such as overalls, gloves, rubber boots, head masks and eye shields.
- Chemical should be stored in safe places away from children.
- Do not eat or drink while working with pesticides
- Wash any spillage from your body as soon as possible
- Clean the equipment after use
- Dispose of empty containers safely as instructed by the manufacturer.
- Do not use empty containers for edible substances.

(b) Outline the maintenance practices on sprayer (06marks)

- Drain the tank of the sprayer before and after use
- Fill the sprayer with water overnight if it is to be used the following day
- Wash both internal and external part of the sprayer when changing to another chemical
- Wash the sprayer at the end of the spraying season with soda (0.5kg of soda in 50 liters of water)
- Remove and clean all the nozzles
- Inspect valves for wear and replace in time

- Keep stock of all spares for replacement

7. (a) Describe the components of a mechanical planter. (15marks)

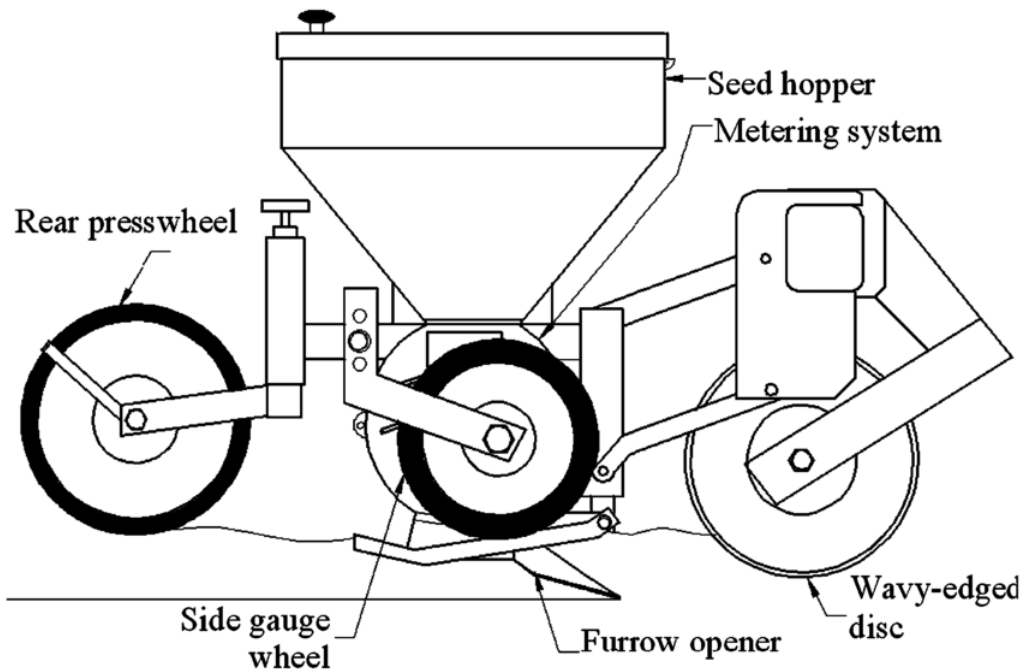

Components of mechanical planter

- **The seed hopper** is where seeds are placed
- **Seed metering device** regulates number of seed planted at a time
- **Seed tube** delivers the seed from hopper into the planting hole
- **Seeds covering device** covers planted seed with soil
- **Frame** provides a base onto which all the components are fitted either directly or indirectly.
- **Transport wheels** allow the machine to be moved easily
- **Depth regulating lever** lowers or raises the furrow opener
- **Boot** joins the furrow opener to the seed tube.
- **Drive mechanism** transmits power from transport wheel to the seed delivery system.
- **Agitator** stirs and keeps the seed flowing freely

(b) What are advantages of using mechanical planter (05marks)

- Plants faster and saves time
- Even placement of seeds
- Reduced seed wastage
- Used in fertilizer application

**SECTION e (20 MARKS)**

**AGRICULTURAL ECONOMICS**

8. (a) Describe the types of production functions experienced in farming (12marks)

**Production function** is relationship between physical inputs (land, labour, capital etc.) and physical outputs (quantity produced). There are two types of production functions i.e. short run production function and long run production function.

**In short run production function** only one factor is variable and the others remain fixed.

**In long run production function** explains the relationship between all inputs and the quantity of output; in other words all factors of production or input are variable

(b) Explain how the production function can be used to determine the most profitable levels of production. (08marks)

The most profitable level of production is determined by plotting total product (TP), average product (AP) and marginal product (MP) against the variable input as shown below

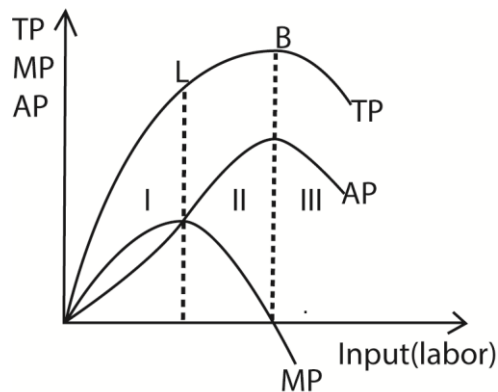

The most profitable level of production is at B when total product is maximum and marginal product is zero.

- Total product is the total amount of goods and services in a given period of time within a given input
- Marginal product is quantity of total goods and services produced when an additional unit of the variable factor is used
- Average product is the total product per unit of variable factors or input.

9. (a) Explain why agricultural co-operatives in Uganda have not been successful?(12marks)

- Lack funds to finance their objective and goals
- Trade liberalization creating unfavorable marketing competition.
- Lack of managerial skills
- Poor financial management
- Political interference
- Illiteracy of members
- Poor record keeping
- Political insecurity
- Price fluctuations of agricultural products
- Poor storage facilities
- Lack of market for produce
- Lack of preservation facilities for agricultural products
- Poor transport network
- High interest rates on credit
- Lack bank security
- Corruption and embezzlement

(b) What would be the benefits of successful agricultural co-operatives in Uganda? (08marks)

- Better marketing facilities for the farmer's products
- Inputs at low cost
- High profits
- Credits at low interest rate
- Ease to get extension services
- Members easily organize group education
- Members develop leadership skill

END

Please obtain free downloadable notes of general paper, biology, economics, geography etc. from [digitalteachers.co.ug](http://digitalteachers.co.ug) website

Thanks

Dr. Bbosa Science