

UACE PHYSICS PAPER 2011

Instructions to the candidates:

Answer **five** questions taking at least one from each of the sections **A, B, C** and **D**, but not more than one question should be chosen from either section **A** or **B**

Any additional question (s) will not be marked.

Mathematical tables and squared paper will be provided

Non programmable calculators may be used.

Assume where necessary

Acceleration due to gravity, g	9.81ms^{-2}
Electron charge, e	$1.6 \times 10^{-19}\text{C}$
Electron mass	$9.11 \times 10^{-31}\text{kg}$
Plank's constant, h	$6.6 \times 10^{-34}\text{Js}$
Speed of light in the vacuum, c	$3.0 \times 10^8\text{ms}^{-1}$
Specific heat capacity of water	$4.200\text{Jkg}^{-1}\text{K}^{-1}$
Avogadro's number, N_A	$6.02 \times 10^{23}\text{mol}^{-1}$
The constant, $\frac{1}{4\pi\epsilon_0}$	$9.0 \times 10^9\text{F}^{-1}\text{m}$
Permittivity of free space, μ_0	$4.0\pi \times 10^{-7}\text{Hm}^{-1}$
Permittivity of free space, ϵ_0	$8.85 \times 10^{-12}\text{Fm}^{-1}$
One electron volt	$1.6 \times 10^{-19}\text{J}$
Resistivity of Nichrome wire at 25°C	$1.2 \times 10^{-6}\Omega\text{m}$

SECTION A

1. (a) Define the following terms as applied to a concave lens:
- (i) principal focus' (01mark)
it is a point on principal axis where rays of light originally parallel and close to principal axis appear to diverge from after reflection by the lens.
 - (ii) radii of curvature (01mark)
are radii of the sphere of which the lens surfaces form part
- (b) A point object is placed at a distance u in front of a diverging lens of focal length, f , to form an image at a distance, v , from the lens.

Derive an expression that relates u , v , and f . (04marks)

Consider in each case a ray incident on the same lens at a small height h above the principal axis as shown:

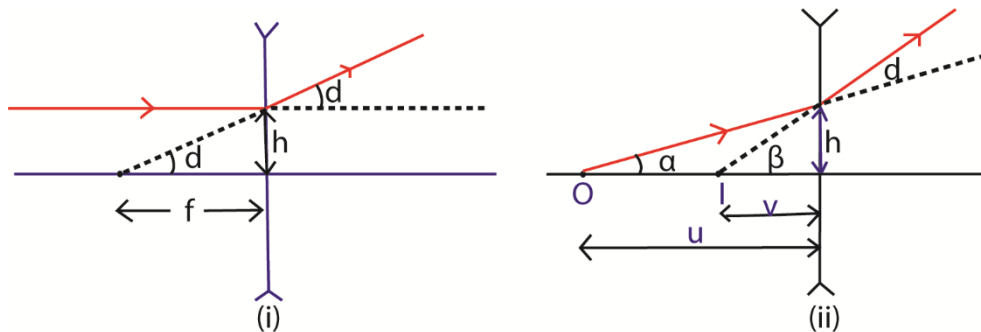

From Fig (i), the close and parallel to principal axis ray appears to diverge from the focal point F and suffers a small deviation d ; since h is very small

Thus $d \approx \tan d = -\frac{h}{f} = \dots\dots\dots$ (i) (F is virtual)

From Fig (ii), the ray from a point object O suffers the same small deviation D to give rise to a point image I .

From geometry, $\beta = \alpha + d$ or $d = \beta - \alpha$

Since α and β are small; $\alpha \approx \tan \alpha = \frac{h}{u}$ and $\beta \approx \tan \beta = -\frac{h}{v}$ (image is virtual)

$d = -\frac{h}{v} - \frac{h}{u} \dots\dots\dots$ (ii)

Equating equations (i) and (ii) gives

$-\frac{h}{f} = -\frac{h}{v} - \frac{h}{u}$

Thus $\frac{1}{f} = \frac{1}{u} + \frac{1}{v}$

- (c) Describe an experiment to determine the focal length of a concave lens using a plane mirror, converging lens and illuminated object. (04marks)

Setup

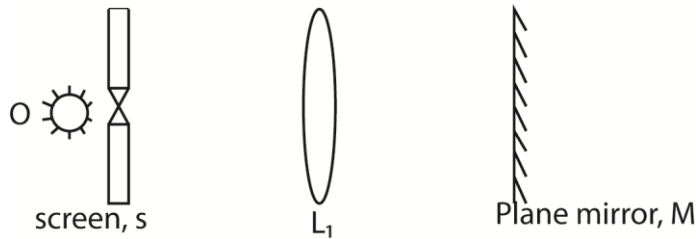

- The apparatus is shown above
 - The wire gauze is illuminate with a bulb and the position of lens L_1 is adjusted until a sharp image of the wire gauze is formed on the object screen, S.
 - The distance SL_1 is measured and recorded as f_1 .
 - The test lens L_2 is now cemented of L_1 and again placed between O and M.
 - The position of the combined lens is adjusted until a sharp image of the wire gauze is formed on S.
 - The distance SL_2 is measured as f_2 .
- Focal length of the test lens, f , is then calculated from, $\frac{1}{f} = \frac{1}{f_2} - \frac{1}{f_1}$

(d) What is meant by a:

(i) visual angle (01mark)

Visual angle is the angle subtended by an object or image at the eye.

(ii) near point (01mark)

The near is the point at which the eye is able to view the object clearly with the greatest details.

(e) A person with a normal near point distance of 25cm wears spectacles with a diverging lens of focal length 200cm in order to correct the far point distance to infinity. Calculate the near point when viewing using the spectacles. (03marks)

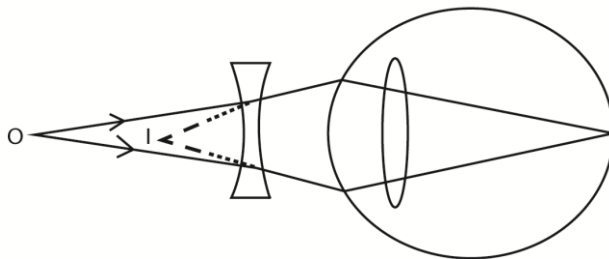

The object at O appear to be at I, the near point for the eye.

Now $v = -25$ cm and $f = -200$ cm

Thus using $\frac{1}{u} + \frac{1}{v} = \frac{1}{f}$

$$\frac{1}{u} = \frac{1}{-200} + \frac{1}{25}$$

$$u = 28.6\text{cm}$$

(f) (i) Draw a ray diagram to show the formation of an image of a distant object in terrestrial telescope in normal adjustment. (03marks)

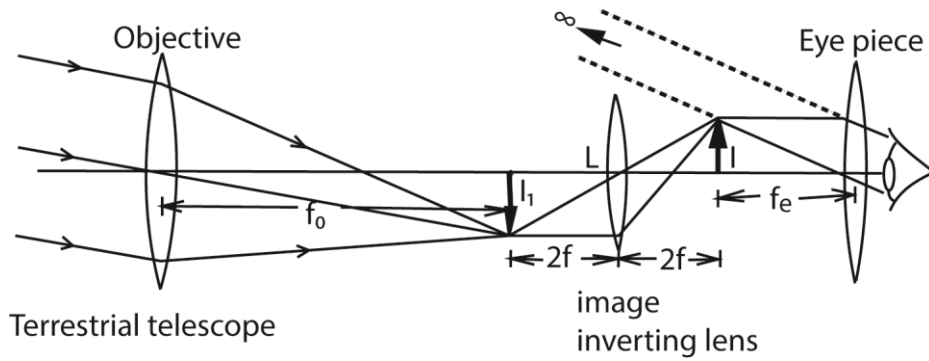

- (iii) State two disadvantages of terrestrial telescope. (02marks)
- Long and bulky
 - Extra diffraction occurs in erecting lens reducing the clarity of the final image
 -

2. (a) What is meant by the term:

- (i) refraction. (01mark)

Refraction is the change in direction of propagation of light as it travels from one medium to another.

- (ii) absolute refractive index? (01mark)

Absolute refractive index of a medium is the ratio of speed of light in vacuum to the speed of light in the medium.

(b) Describe an experiment to determine the refractive index of a liquid using a travelling microscope. (04marks)

Measurement of refractive index of a liquid using travelling microscope or by apparent depth method.

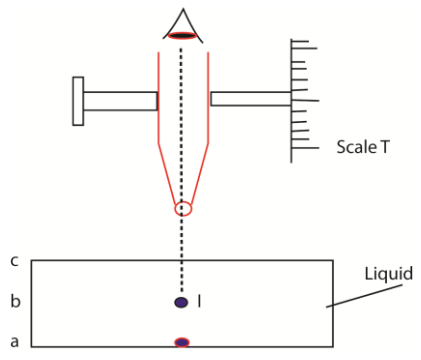

A vertically traveling microscope having a graduated scale **T** besides it is focused on sand particles placed at **O** on bottom of the container. The scale reading **a** on **T** is noted.

A liquid whose refractive index is required is filled in a container and the microscope is raised until the particles are refocused at **I**. The scale reading **b** is again noted.

Finally the traveling microscope is focused on the liquid surface giving a scale reading **c**.

Thus $n_L = \left[\frac{c-a}{c-b} \right]$

(c) The figure below shows monochromatic light X incident towards A on vertical screen.

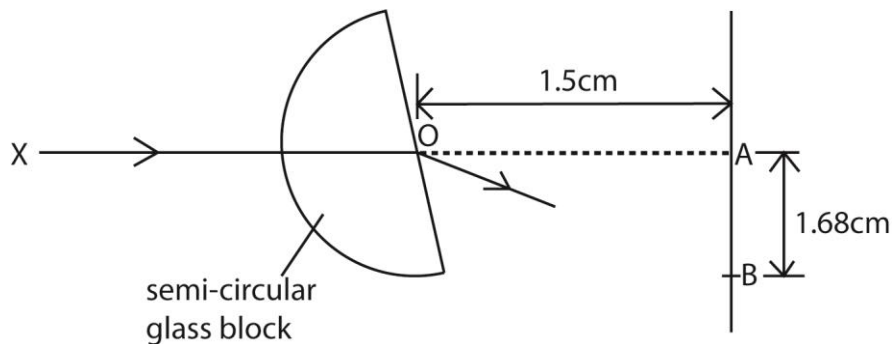

When the semicircular glass block is placed across the path of light with its flat face parallel to the screen, a bright spot is formed at A. When the glass block is rotated about a horizontal axis through O, the bright spot moves from A to B and then just disappears. At B, distance 1.68cm from A.

(i) Find the refractive index of the material of the glass block. (04marks)

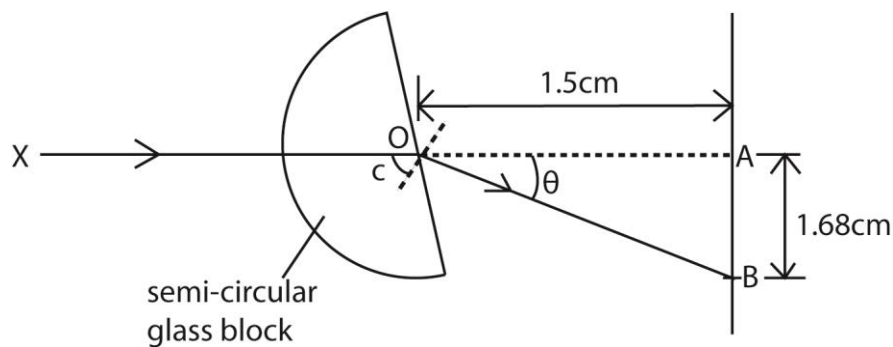

When the spot just disappear at B, the total internal reflection just occurs

$$n = \frac{1}{\sin c} \text{ where } c = 90 - \theta$$

$$\text{but } \tan \theta = \frac{1.68}{1.5} = 1.2; \theta = 48.2$$

$$c = 90 - 48.2 = 41.8$$

$$n = \frac{1}{\sin 41.8} = 1.5$$

(ii) Explain whether AB would be longer or shorter if the block of glass of higher refractive index was used.

When the refractive index is high the ray is refracted more, AB becomes longer.

(d) (i) A ray of monochromatic light is incident at a small angle of incidence on a small-angle prism in air. Obtain the expression, $d = (n-1)A$, for the deviation, d , of light by the prism, where A is the refracting angle of the prism and n , is the refractive index. (04marks)

Solution

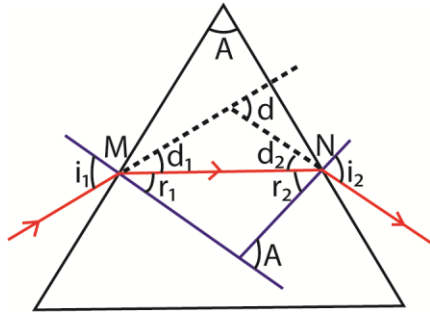

The small refracting angle of this prism causes the angle i_1 , r_1 , r_2 and i_2 to be small such that $\sin i_1 \approx i_1$, $\sin r_1 \approx r_1$, $\sin r_2 \approx r_2$ and $\sin i_2 \approx i_2$

From the diagram, $d = d_1 + d_2$

But $d_1 = i_1 - r_1$ and $d_2 = i_2 - r_2$

$$\Rightarrow d = (i_1 - r_1) + (i_2 - r_2)$$

On simplifying $d = i_1 + i_2 - (r_1 + r_2)$

but $r_1 + r_2 = A$

$$\Rightarrow d = i_1 + i_2 - A \dots\dots\dots(a)$$

At M Snell's law becomes.

$$n_a \sin i_1 = n \sin r_1$$

For small angles this gives $i_1 = nr_1 \dots\dots\dots(b)$

Similarly at N Snell's law becomes $i_2 = nr_2 \dots\dots\dots(c)$

Substituting equation (b) and (c) in (a) gives

$$d = nr_1 + nr_2 - A$$

$$d = n(r_1 + r_2) - A$$

but $r_1 + r_2 = A$

$$\Rightarrow d = nA - A$$

$$\mathbf{d = (n - 1)A}$$

(ii) Calculate the minimum deviation produced by a 60° prism if the refractive index of the glass is 1.50. (03marks)

$$\text{Using } n = \frac{\sin\left(\frac{D_{\min} + A}{2}\right)}{\sin\frac{A}{2}}$$

$$1.5 = \frac{\sin\left(\frac{d_{\min} + 60}{2}\right)}{\sin\frac{60}{2}}$$

$$d_{\min} = 37.18^\circ$$

(iii) State any two applications of total internal reflection. (01marks)

- Transmission of light by optical fiber
- Reflecting prisms in binoculars, periscopes

3. (a) (i) Define the terms wave front and a ray in reference to a progressive wave (02mark)

Wave front is a section through an advancing wave along which all particles are in phase along a ray in the direction of advancing wave.

- (ii) Draw a sketch diagram showing reflection of a circular wave by a plane reflector.

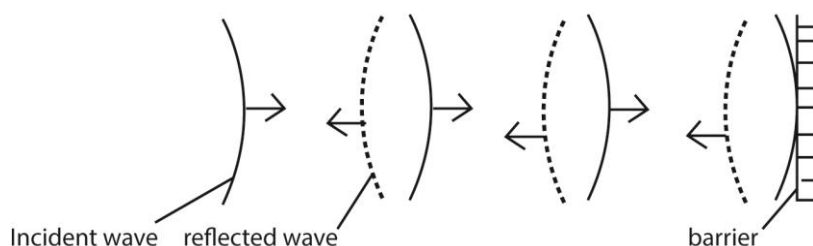

- (b) The figure below shows a wave travelling in positive x- direction away from origin with a velocity of 9ms^{-1} .

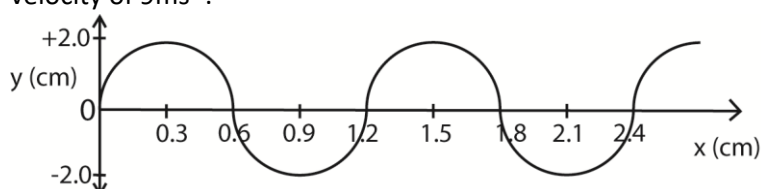

- (i) What is the period of the wave? (03marks)

$$\text{Wavelength} = 1.2\text{cm} = 0.12\text{m}$$

$$\text{Velocity} = 9\text{ms}^{-1}$$

$$\text{Period, } T = \frac{\lambda}{v} = \frac{1.2 \times 10^{-2}}{9} = 1.3 \times 10^{-3}\text{ms}^{-1}$$

- (ii) Show that the displacement equation for the wave is $y = 2\sin\frac{5}{3}\pi(900t - x)$ (03marks)

The wave is moving from left to right

$$\text{c.f. } y = a\sin 2\pi\left(ft - \frac{x}{\lambda}\right)$$

here $a = 2\text{cm}$, $f = 750\text{Hz}$, and $\lambda = 1.2$

$$\therefore y = 2\sin 2\pi\left(750t - \frac{x}{1.2}\right)$$

Or

$$\text{c.f. } y = a\sin\frac{2\pi}{\lambda}(vt - x)$$

here $a = 2\text{cm}$, $\lambda = 1.2\text{cm}$, and $v = 900\text{cms}^{-1}$

$$y = 2\sin\frac{2\pi}{1.2}(900t - x)$$

$$= 2\sin\frac{20\pi}{12}(900t - x)$$

$$= 2\sin\frac{5\pi}{3}(900t - x)$$

- (c) What is meant by Doppler Effect? (01mark)

This is the apparent change in frequency of a wave due to relative motion between the source and observer.

- (d) One species of bats locates obstacles by emitting high frequency sound waves and detecting the reflected waves. A bat flying at a steady speed of 5ms^{-1} emits sound of frequency 78.0kHz and is reflected back to it.

- (i) Derive the equation for the frequency of the sound waves reaching the bat after reflection (05marks)

Suppose the velocity of sound wave is c and that of the bat is v_0 and the frequency is f .

The velocity v' of reflected sound relative to the bat is given by $v' = v_0 + c$.

The apparent wave length $\lambda' = \frac{c - v_0}{f}$

But the apparent frequency, $f' = \frac{v'}{\lambda'} = \frac{c + v_0}{\frac{c - v_0}{f}}$

$$\text{Hence } f' = \frac{c + v_0}{c - v_0} f$$

- (ii) Calculate the frequency of sound received by the bat given the speed of sound in air is 340ms^{-1} . (02 marks)

From, $f' = \frac{c + v_0}{c - v_0} f$

$$f' = \frac{340+5}{340-5} \times 78 \times 10^3 = 90.3 \text{ kHz}$$

- (e) (i) What is meant by intensity of a sound note? (01mark)

This is the rate of flow of energy through an area of 1m^2 perpendicular to the direction of flow of sound wave.

- (ii) Distinguish between loudness and pitch of a sound note. (01mark)

Loudness of sound is dependent on intensity whereas pitch is dependent frequency, i.e. the higher the frequency the higher the pitch.

4. (a) What is meant by the following terms

- (iii) Unpolarized light, (01mark)

Unpolarized light is one whose vibrations in electric and magnetic vectors take place in more than one plane.

- (iv) Plane polarized light (01mark)

It is the one whose electric vector varies in only one plane.

- (b) (i) Describe briefly how plane polarized light is produced by double refraction (03marks)

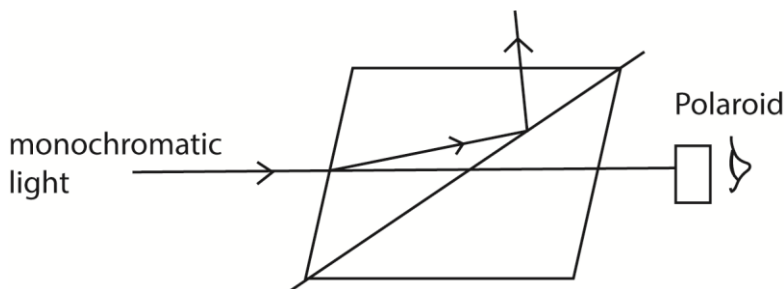

- A narrow beam of ordinary light is made incident on nicol prism and viewed through analyzer as shown above
- The angle of incidence is gradually increased or change and at each angle, the Polaroid is rotated about an axis through its plane.
- At certain angle of incidence, light is completely extinguished
- At this point, the emergent light is plane polarized.

- (ii) Explain briefly one application of polarized light. (02marks)

- When polarized light is passed through a stressed material, bright and dark fringes are seen on screen which vary according to the concentration of stress. Thus stress analysis.
- In determination of the concentration of sugar in solution, polarized light is passed through the solution and viewed through an analyzer. The analyzer is turned through angle until light is extinguished. This angle is proportional to the concentration

(c) Explain

(i) How two coherent sources are obtained using a biprism (03marks)

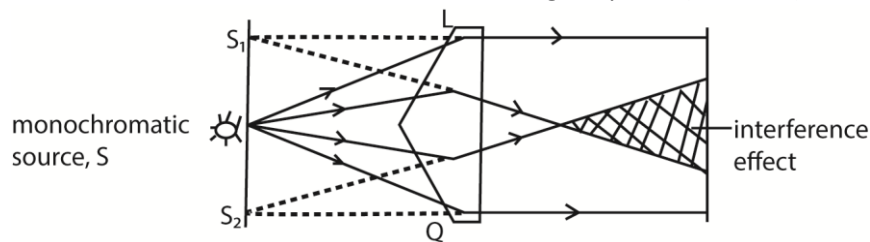

- A prism of a very large angle is placed with its refractive edge facing a monochromatic source of light, S.
- Light incident on face L is refracted to appear to come from a point S_1 and that incident on Q appears to come from S_2 due to refraction.
- The two sources are coherent since they originate from the same source S leading to interference where they superpose.

(ii) Why interference effects are not observed in thick films (03marks)

The bright fringes are formed when the path difference, $d = \left(n - \frac{1}{2}\right) \lambda$, where $n = 1, 2, 3 \dots$

But for thick film illuminated normally with white light, each color attains this path difference and form bright bands. So when these different colors overlap leading cause uniform illumination and the interference pattern disappear.

(d) In Young's double slit experiment, the slits are separated by 0.28mm and the screen is 4m away. The distance between the fourth bright fringe and the central fringe is 1.2cm. Determine the wavelength of light used in the experiment. (04marks)

Solution

The distance between the fourth and bright fringes and the central fringe is equivalent to the separations.

$$4y = 1.2 \times 10^{-2} \text{m where } y \text{ is the fringe separation}$$

$$y = 3 \times 10^{-3} \text{m}$$

from $\lambda = \frac{ay}{D}$ where a is the slit separation and D is the fringe-screen difference

$$\lambda = \frac{0.28 \times 10^{-3} \times 3.0 \times 10^{-3}}{4} = 2.1 \times 10^{-7} \text{m}$$

(e) Explain the effect of increasing the number of narrow slits in diffraction grating on the intensity of diffraction fringes. (03marks)

Increasing the number of slits, the intensity of the principal maxima increases while that subsidiary maxima decreases. The interference at the principal maxima are always

constructive hence intensity increases. Interference at the subsidiary maxima is always destructive, hence the intensity decreases.

SECTION B

5. (a) Define the following terms as applied to alternating voltage

(i) Root mean square value (01 marks)

Root mean square value is the value of direct current which dissipates heat in a given resistor at the same rate as the a.c.

(ii) Peak value

Peak value is the maximum value of alternating Voltage.

(b) (i) An alternating voltage is applied across a capacitor of capacitance, C. show that current in the circuit leads the voltage by $\pi/2$

Instantaneous charge on the capacitor.

$$\text{Let } V = V_0 \sin \omega t = V_0 \sin 2\pi f t$$

$$Q = CV = CV_0 \sin 2\pi f t$$

$$\text{But } I = \frac{dQ}{dt} = \frac{d(CV_0 \sin 2\pi f t)}{dt}$$

$$= 2\pi f CV_0 \cos 2\pi f t.$$

$$\text{But } \cos 2\pi f t = \sin \left(2\pi f t + \frac{\pi}{2} \right).$$

This shows that the current varies a quarter-cycle out of step with the voltage-or, as is more often said, $\pi/2$ out of phase.

When the voltage is a maximum, so is the charge on the capacitor. It is therefore not charging and the current is zero.

When the voltage starts to fall, the capacitor starts to discharge; the rate of discharging, or current, reaches its maximum when the capacitor is completely discharged and the voltage across it is zero.

(ii) Find the expression for capacitive reactance in terms of frequency, f, and capacitance, C.

$$I_0 = CV_0 \omega$$

$$XC = \frac{V_0}{I_0} = \frac{1}{C\omega} = \frac{1}{2\pi f C}$$

- (iii) A capacitor of $0.1\mu\text{F}$ is in series with an a.c. source of frequency 500Hz . If the r.m.s value of the current flowing is 6mA , calculate the voltage across the capacitor (03marks)

$$\Rightarrow V_{r.m.s} = \frac{I_{r.m.s}}{2\pi fC} = \frac{6 \times 10^{-3}}{2\pi \times 500 \times 0.1 \times 10^{-6}} = 19.1\text{V}$$

- (c) A bulb is connected in series with an inductive coil and a d.c source as shown in the figure below

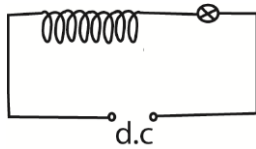

- (i) What happens to the brightness of the bulb when an iron core is inserted in the coil? (01mark)

Initially the bulb dims and becomes bright.

- (ii) Explain what happens to the brightness of the bulb when the d.c. source is replaced with a.c. and an iron core inserted in the coil. (03marks)

Initially the bulb is dim due to back e.m.f in the coil and then become bright because the back e.m.f decays to zero and current increases to the maximum

- (d) (i) What is hysteresis loss ? (01mark)

Hysteresis loss is the loss in energy due to the change in magnetic domains from one direction to the other as current changes

- (ii) How can hysteresis loss be minimized in a.c. transformer? (01mark)

It is minimized by using soft magnetic materials like soft iron and perm alloy in which energy required

- (iii) Explain why the primary current in the a.c. transformer increases when the secondary coil is connected to the load? (04marks)

When a load is connected to the secondary, current flows in the secondary which induces magnetic flux in the core in opposition to magnetic flux due to primary current.

Magnetic flux in the core due to primary current thus reduces.

This leads to a reduction in back e.m.f in the primary and hence the primary current increases.

6. (a)(i) Draw a well labelled diagram to show the structure of repulsion type moving iron ammeter (02marks)

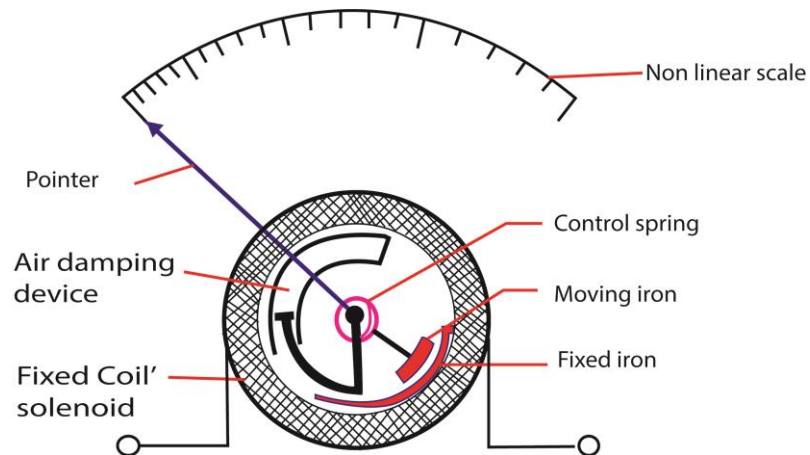

- (ii) Explain how the ammeter in (a)(i) above is able to measure alternating current. (05marks)

When a current is passed through the coil, the iron rods magnetize in the same poles adjacent to each other in whatever the direction of current. Hence they repel and the pointer move in the same direction until it is stopped by the restoring spring.

Since the magnetic force is proportional to the square of the average current, hence, the deflection is proportional to the square of average current.

Advantage: it measured both direct and alternating current.

Disadvantage: it has nonlinear scale

- (b) (i) Write down an expression for magnetic flux density at the center of a flat circular coil, N , turns each of radius, a , carrying current I . (01mark)

$$B = \frac{\mu_0 NI}{2a} \text{ where } \mu_0 = 4\pi \times 10^{-7} \text{ Hm}^{-7}.$$

- (ii) Describe how you would determine the value of the earth's magnetic flux density at a place, using a search coil. (06marks)

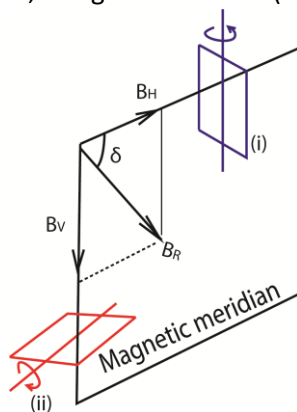

- A coil of known number of turns, N (about 100) and area A is connected to a calibrated ballistic galvanometer so that the total resistance in the circuit is R.
- The coil is placed in a vertical plane perpendicular to the magnetic meridian of the earth as shown in (i) in figure above. The coil is then rotated through 180° about the vertical axis. The maximum throw θ_1 is noted.
- The coil is then placed with its plane in horizontal plane perpendicular to the magnetic meridian of the earth as shown in (ii) in figure above. The coil is then rotated through 180° about the horizontal axis. The maximum throw θ_2 is noted.

- Treatment of results

$$B_H = \frac{k\theta_1 R}{2NA} \text{ and } B_V = \frac{k\theta_2 R}{2NA}$$

k is obtained by charging standard capacitor to a known p.d V and then discharging it through the ballistic galvanometer and the deflection α is noted.

$$k = \frac{CV}{\alpha}$$

Then B is calculated from $b = \sqrt{B_H^2 + B_V^2}$

- (c) A coil of 50 turns and radius 4cm is placed with its plane in the earth's magnetic meridian. A compass needle is placed at the center of the coil. When a current of 0.1A passes through the coil, the compass needle deflects through 40° . When the current is reversed, the needle deflects through 43° in opposite direction.

(i) Calculate the horizontal component of the earth's flux density. (04marks)

$$\tan \theta = \frac{B_{coil}}{B_H} \text{ and } B_{coil} = \frac{\mu_0 NI}{2R} \text{ where } \theta \text{ is average deflection}$$

$$\text{Hence } \tan \theta = \frac{\mu_0 NI}{2RB_H}$$

$$B_H = \frac{\mu_0 NI}{2R \tan \theta} = \frac{4\pi \times 10^{-7} \times 50 \times 0.1}{2 \times 4 \times 10^{-2} \tan\left(\frac{40+43}{2}\right)} = 8.87 \times 10^{-5} \text{T}$$

(ii) Calculate the magnetic flux density of the earth at that place given that the angle of dip at the place is 15° .

$$\frac{B_H}{B} = \cos \delta \text{ where } \delta \text{ is the angle of dip}$$

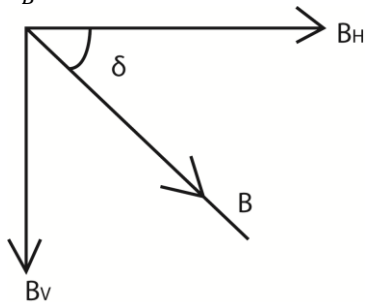

$$B = B_H \sec \delta$$

$$= 8.87 \times 10^{-5} \sec 15 = 9.18 \times 10^{-5} \text{T}$$

7. (a) State the laws of electromagnetic induction. (02marks)

Faraday's laws states that the magnitude of the induced e.m.f in a conductor is directly proportional to the rate of change of magnetic flux linking the conductor.

Lenz's law states that the direction of the induced e.m.f is such that the current which it causes to flow opposes the change which is producing it.

(b) (i) A circular metal disc of radius R , rotates in an anticlockwise direction at angular velocity, ω , in a uniform magnetic field of flux density, B , directed in to paper as shown in the figure below

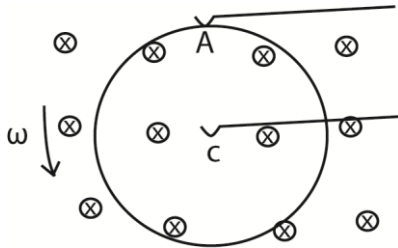

A and C are contact points

Derive an expression for e.m.f induced between A and C.

Let r = radius of the disc

Thus AC cuts the magnetic flux continuously.

The average velocity V of AC = $\frac{0+r\omega}{2} = \frac{r\omega}{2}$

∴ Induced e.m.f in AC = $E = BLV$

$$= \frac{Br.r\omega}{2}$$

$$= \frac{1}{2}Br^2\omega$$

(ii) A copper disc of radius 10cm is placed in a uniform magnetic field of flux density, 0.02T, with its plane perpendicular to the field. If the disc is rotated parallel to the field about an axis through its center at 3000 revmin⁻¹, calculate the e.m.f that is generated between its rim and the centre. (03marks)

Since $E = \frac{1}{2}Br^2\omega$, $\omega = 2\pi f$

$$= \frac{1}{2}Br^2 \cdot 2\pi f$$

$$= Br^2\pi f$$

If $f = 3000\text{revmin}^{-1}$;

$$= \frac{3000}{60} = 50\text{Hz}$$

$$\therefore 0.02 \times (0.1)^2 \times 2 \times 3.14 \times 50 = 3.14 \times 10^{-2}\text{V}$$

(c) Describe an experiment to demonstrate mutual induction (04marks)

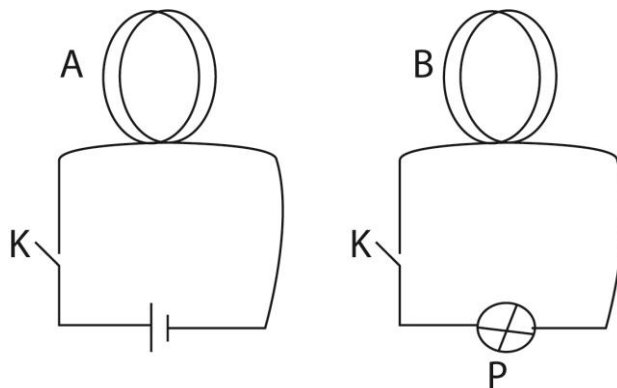

Coil A and B are placed close to each other. When K is closed bulb P lights. Hence e.m.f is induced in B. Since the circuit is closed current flows and the bulb lights.

- (d) The diagram in the figure below shows the arrangement by which a laboratory balance is critically damped. The aluminium beam supporting the pan moves in the magnetic field of two powerful magnets.

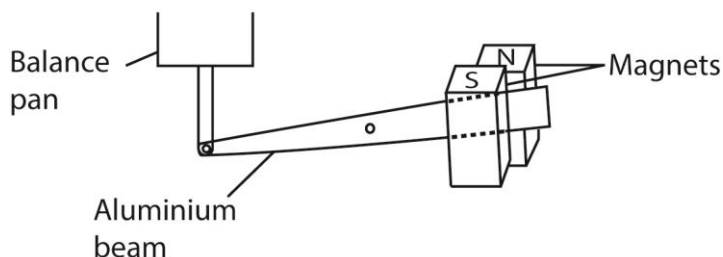

- (i) Explain how damping is caused. (03marks)

When the beam moves between the magnetic poles, it cuts the magnetic field. Eddy currents are induced in the beam whose magnetic field opposes its movement. Hence damping the motion.

- (ii) What change would occur in the performance of the balance if the magnets were replaced by weaker ones (01mark)

The beam takes longer to settle.

- (e)(i) Define the ampere (01mark)

The ampere is the current which when flowing in each of the two long parallel wires of negligible cross-sectional area and 1m apart in a vacuum produces a force of $2 \times 10^{-7} \text{Nm}^{-1}$ on each other.

- (ii) Two parallel wire, P and Q of equal length 0.1m, each carrying a current of 10A are a distance 0.05m apart with P directly above Q. If P remains stationary, find the weight of P. (03marks)

Force due to magnetic field on P = weight of P, W.

$$W = \frac{\mu_0 I_1 I_2 L}{2\pi a} = \frac{4\pi \times 10^{-7} \times 10 \times 10 \times 0.1}{2\pi \times 0.05} = 4.0 \times 10^{-5} \text{N}$$

SECTION C

8. (a)(i) Define electromotive force of a battery. (01mark)

Electromotive force of a battery is the energy supplied by the battery to transfer 1C of charge across a complete circuit in which the battery is connected.

- (ii) A cell of e.m.f, E and internal resistance r, drives current through a resistor of resistance, R connected in series with it. Derive an expression for efficiency of the circuit. (04marks)

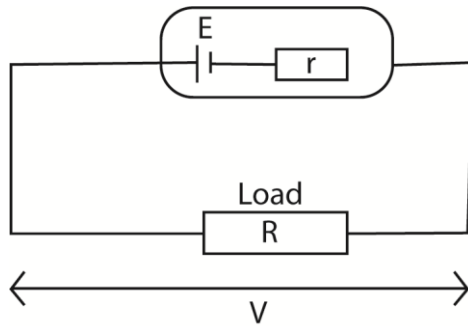

Power delivered to the load, $P_{out} = IV$

Power supplied by battery, $P_{in} = IE$

$$\text{Efficiency, } \eta = \frac{P_{out}}{P_{input}} \times 100\%$$

$$= \frac{IV}{IE} \times 100\%$$

But $V = IR$ and $E = I(R + r)$

$$\therefore \eta = \frac{R}{R+r} \times 100\%$$

(b) Describe with the aid of a diagram how you would standardize a slide wire potentiometer. (03marks)

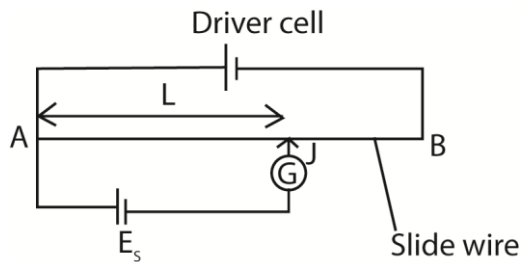

The slide contact is moved along the uniform wire AB until a point where the galvanometer shows no deflection. Distance L is noted

At the balance length, p.d across AJ = e.m.f of E_s

$$E_s = kL$$

$$\therefore k = \frac{E_s}{L}, \text{ where } k = \text{calibration constant.}$$

(c) In the figure below, AB is a uniform resistance wire of length 1m and resistance 4Ω . X is a driver cell of e.m.f 3V and internal resistance 1Ω and E_s is a standard cell, R_s is a standard resistor of resistance 10Ω which is connected in series with cell Y of e.m.f 1.22 V and internal resistance 0.5Ω

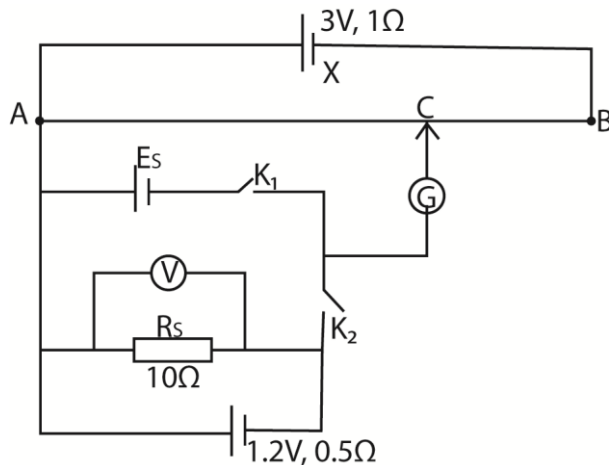

With switch K_1 closed and K_2 open, the balance length, AC is 60cm while the voltmeter reading is 1.14V. With K_1 open and K_2 closed, the balance length is 80cm. Calculate the

- (i) E.m.f E_s , of standard cell. (03marks)

$$\text{Driver current, } I_d = \frac{E_x}{R} = \frac{3}{1+4} = \frac{3}{5} = 0.6A$$

$$\text{Resistance per cm of the wire} = \frac{4}{100} = 0.04\Omega$$

$$E_s = k \times 60 \text{ where } k = \text{p.d per cm}$$

$$= 0.04 \times 0.6 \times 60$$

$$= 1.44V$$

- (ii) Percentage error in the voltmeter reading (03marks)

When K_1 is open and K_2 is closed,

$$(I_s \times R_s) = k \times 80 = 0.04 \times 0.6 \times 80 = 1.92V$$

$$VR = 1.14$$

$$\text{Error} = 1.92 - 1.14 = 0.78V$$

$$\% \text{ error} = \frac{0.78}{1.92} \times 100 = 40.6\%$$

- (d) Describe with the aid of a circuit diagram how you would measure the temperature coefficient of resistance of a material in form of a wire. (06marks)

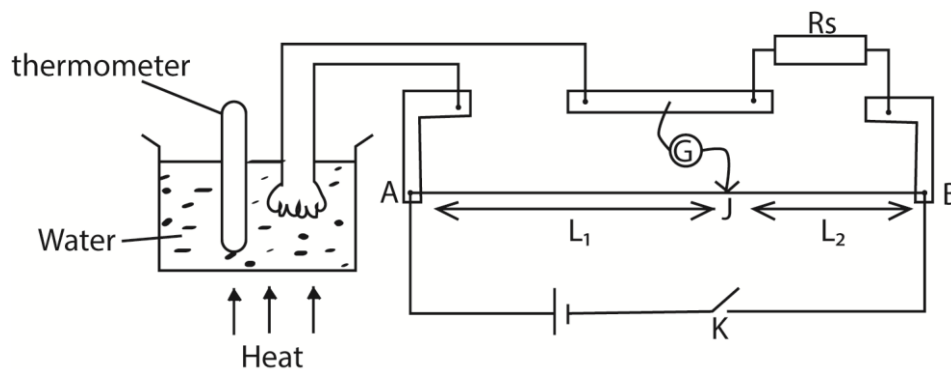

- The apparatus are set up as above
- The specimen wire is made into a coil and immersed in water bath.

- The ends of the coil are connected to the left gap of the Meter Bridge and standard resistor, R_s in the right hand gap.
- The water bath is heated to a suitable temperature, θ , and after through stirring and K is closed. The jokey is tapped to a point on the slide wire AB where the galvanometer shows no deflection
- The balance lengths L_1 and L_2 are noted and recorded.
- The procedure is repeated for different values of θ and the results are tabulated including values of $R_\theta = R_s \times \frac{L_1}{L_2}$.
- A graph of R_θ against θ is plotted and its slope S and intercept R_0 on the R_θ axis are obtained.
- Mean temperature coefficient, $\alpha = \frac{S}{R_0}$

9. (a) State coulomb's law of electrostatics. (01marks)

The force between two point charges is directly proportional to the product of the magnitude of charges and inversely proportional to the square of the distance of the separation of charges.

(b) Derive the relation between electric field intensity, E , and electric potential, V , due to a charge at a point. (04marks)

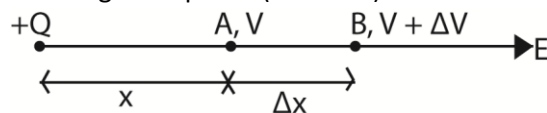

If the potential at A is V and that at B is $V + \Delta V$, then the potential difference between A and

$$\begin{aligned} B, V_{AB} &= V_A - V_B \\ &= V - (V + \Delta V) \\ &= -\Delta V \end{aligned}$$

The work done in moving 1C of charge from B to A = $E(\Delta x) = V_{AB}$

$$E\Delta x = -\Delta V$$

$$E = -\frac{\Delta V}{\Delta x}$$

In limits, as $\Delta x \rightarrow 0$, E becomes the electric field strength at a point

$$\therefore E = -\frac{dV}{dx}$$

(c) Two pith ball P and Q each of mass 0.1g are separately suspended from the same point by threads 30cm long. When the balls are given equal charges, they repel each other and come to rest 18cm apart. Calculate the magnitude of charge on each ball. (06marks)

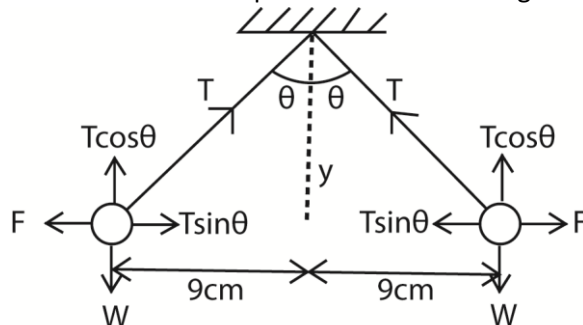

$$y^2 = 30^2 - 9^2$$

$$y = 28.62$$

Horizontal component, $F = T \sin \theta$ (i)

Vertical component, $mg = T \cos \theta$ (ii)

From (i) and (ii)

$$\frac{F}{mg} = \tan \theta$$

$$F = mg \tan \theta = 0.1 \times 10.3 \times 9.81 \times \frac{9}{28.62} = 0.309 \times 10^{-3}$$

$$\text{But } F = \frac{kQ^2}{r^2} = \frac{9 \times 10^9 \times Q^2}{(18 \times 10^{-2})^2} = 0.309 \times 10^{-3}$$

$$Q = 3.33 \times 10^{-8} \text{C}$$

(d) Describe how you would investigate the distribution of charge on pear shaped conductor. (04marks)

- A proof plane is placed on a part of a charged conductor transferred into a hollow metallic can placed on the cap of neutral electroscope and the deflection of the electroscope noted.
- The procedure is repeated for the different parts of the charged conductor.
- It is observed that the greatest deflection is got for a proof plane placed at the sharpest point of the charged conductor. This implies that charges are most concentrated where the curvature is greatest.

(e) Explain how a charged body attracts uncharged conductor. (03marks)

- When a charged body is brought near uncharged conductor, the electrons in the conductor are displaced.
- The end nearest the charged body acquires a charge opposite to that of charged body while the end remote acquires a charge similar to that of charged body.
- Consequently, the end nearest to the charge body is attracted.

(f) Describe how an electroscope can be used to distinguish a conductor from an insulator. (01mark)

- An electroscope is given a charge and the divergence is noted.
- The material is brought into contact with the cap of electroscope.
- When there is no change in divergence, the material is an insulator
- When the divergence reduces, the material is a conductor.

10. (a) Define dielectric strength. (01mark)

Dielectric strength is the maximum electric field intensity an insulator can withstand without conducting.

Or

The maximum potential gradient an insulator can withstand without conducting

(b) (i) Explain briefly how a capacitor in which the potential difference, V_0 across the plates, can be fully discharged. (02marks)

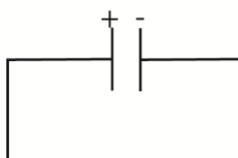

The wire is connected from the positive plate to the negative plate. Electrons flow from the negative plate to the positive plate neutralizing the positive charges. The flow of electrons continues until all the capacitor is fully neutralized.

- (ii) Sketch a graph showing a variation of potential difference with time for the process in (b)(i) above

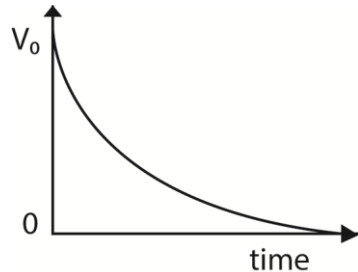

- (c) (i) Two capacitors of capacitance C_1 and C_2 are connected in series. Show that the effective capacitance, C , is given by

$$C = \frac{C_1 C_2}{C_1 + C_2}$$

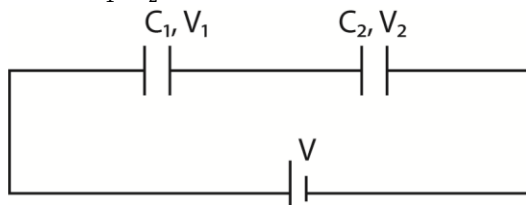

In series, the charge on each capacitor, Q , is the same, let C be the effective charge

$$V = V_1 + V_2$$

$$\text{Also, } V = \frac{Q}{C} = \frac{Q}{C_1} + \frac{Q}{C_2}$$

$$\text{Or } \frac{1}{C} = \frac{1}{C_1} + \frac{1}{C_2}$$

$$C = \frac{C_1 C_2}{C_1 + C_2}$$

- (ii) A $10.0\mu\text{F}$ capacitor charged to 200V is connected across uncharged $50\mu\text{F}$ capacitor. Calculate the total energy stored in both capacitors before and after connection (04marks)

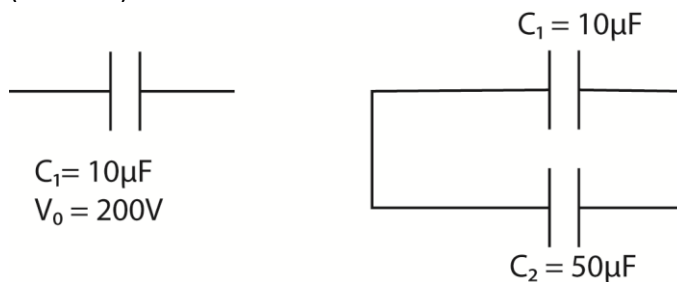

$$\text{Total energy stored before} = \frac{1}{2} C V^2 = \frac{1}{2} \times 10 \times 10^{-6} \times 200^2 = 0.2\text{J}$$

$$\text{Effective capacitance in series after connection} = \frac{10 \times 50}{10 + 50} = 8.33\mu\text{F}$$

$$\text{Total energy stored after connection} = \frac{1}{2} \times 8.33 \times 10^{-6} \times 200^2 = 0.17\text{J}$$

- (iii) Account for the difference in the energies calculated in (c)(ii) above. (01mark)
The stored energy after connection is less due to energy loss in the connecting wire.

- (d) In the figure below, Q_1 and Q_2 are point charges of magnitude $+5.0\mu\text{C}$ and $-5.0\mu\text{C}$ respectively

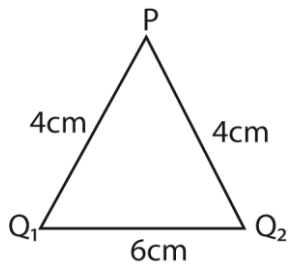

Calculate the

- (i) Electric field intensity at P

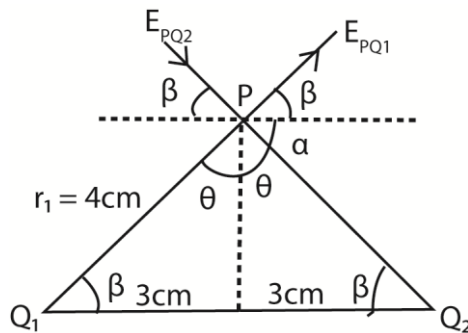

From electric field intensity, $E = \frac{Q}{4\pi\epsilon_0 r^2}$

$$E_{PQ1} = \frac{Q}{4\pi\epsilon_0 r_1^2} = \frac{(9 \times 10^9) \times 5 \times 10^{-6}}{(4 \times 10^{-2})^2} = 2.8 \times 10^7 \text{NC}^{-1}$$

$$E_{PQ2} = \frac{-Q}{4\pi\epsilon_0 r_1^2} = \frac{-(9 \times 10^9) \times 5 \times 10^{-6}}{(4 \times 10^{-2})^2} = -2.8 \times 10^7 \text{NC}^{-1}$$

Using cosine rule, $6^2 = 4^2 + 4^2 - 2 \times 4 \times 4 \cos\theta$

$$\theta = \cos^{-1}\left(\frac{36-32}{32}\right) = 97.2^\circ$$

$$\alpha = 180 - 97.20 = 82.8^\circ$$

Triangle of intensities

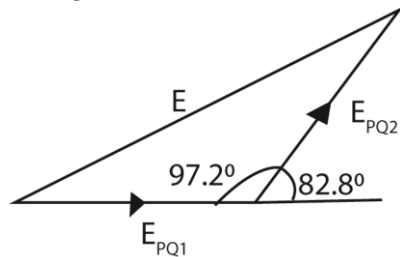

$$E^2 = E_{PQ1}^2 + E_{PQ2}^2 - 2 \times E_{PQ1} \times E_{PQ2} \cos 97.2^\circ$$

$$E = 4.2 \times 10^7 \text{NC}^{-1}$$

Since E_{PQ1} and E_{PQ2} have equal magnitude, then the result bisects the angle between them.

So it acts horizontally to right

- (ii) Potential energy of appoint charge Q_3 of $0.8\mu\text{F}$ placed at P

$$\begin{aligned} \text{From } V &= \sum \frac{Q}{4\pi\epsilon_0 r} \\ &= \frac{Q_1}{4\pi\epsilon_0 r_1} + \frac{Q_2}{4\pi\epsilon_0 r_2} \\ &= 9 \times 10^9 \left[\frac{5 \times 10^{-6}}{4 \times 10^{-2}} - \frac{5 \times 10^{-6}}{4 \times 10^{-2}} \right] = 0 \end{aligned}$$

But potential energy = $QV = 0$

END