



Dr. Blosa Science

Sponsored by  
**The Science Foundation College**  
**Uganda East Africa**  
Senior one to senior six  
+256 778 633 682, 753 802709  
**Based On, best for science**

digitalteachers.co.ug



Nurture your dreams

NAME:..... STREAM.....

## SENIOR FOUR

553/1

## BIOLOGY

## PAPER 1

## EXAM 16

TIME: 2 ½ HOURS

### Instructions:

Answer all questions in section A and B, plus two questions in section C.  
Section A circle the correct alternative.  
Answers to section C must be written on the answer booklets provided.

### For Examiner's use only

SECTION/QUESTION	MARKS
A	
B	
C	
TOTAL	

### SECTION A:

- Which of the following is a viral disease?  
A: typhoid                      **B: polio**                      C: tetanus                      D: syphilis
- What happens to a person after consuming food with high salt content?  
A: Osmotic pressure of his blood decreases  
**B: a lot of ADH will be produced by his pituitary glands**  
C: much urine will be produced  
D: less ADH will be produced.  
ADH promotes reabsorption of water from renal filtrate to dilute blood
- If the contents of blood capillary in a villus of a man is analysed, it will be found to have



14. A nocturnal bird was found to have a retina composed entirely of rods. This means that it  
 A: has good colour vision                      **B: has accurate vision in dim light**  
 C: can judge distance very well              D: can only focus on distant objects.
15. Which of the following is not carried in blood?  
 A: amino acids                                      B: carbon dioxide  
 C: secretin    D: **Trypsin**  
 Trypsin is an enzyme and enzymes are not carried in blood
16. The graph below shows the effect of auxin concentration on growth of root and shoot

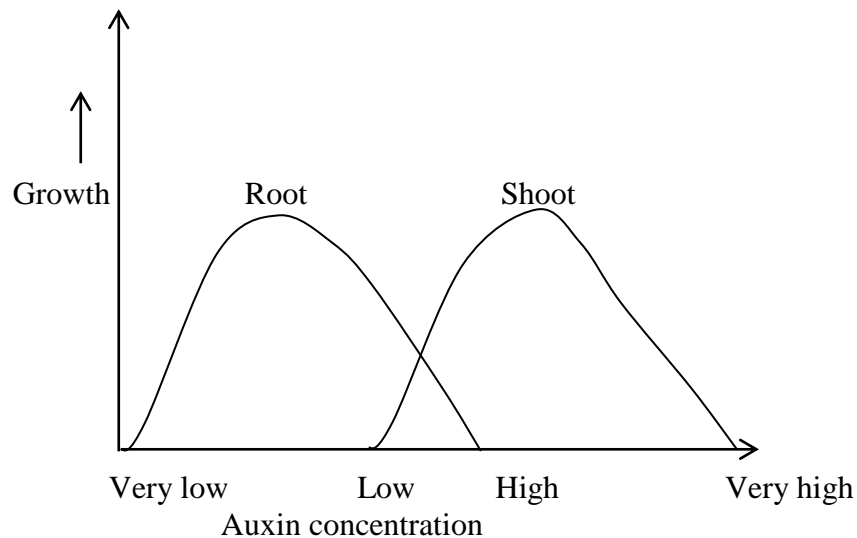

From the graph we can say that

- A:** shoots require a higher auxin concentration than roots for maximum growth  
**B:** very low auxin concentration is most effective on root growth  
**C:** very high auxin concentration is favourable to growth of shoot  
**D:** Auxin concentration which retards root growth also retards shoot growth.
17. Which of the following is true about protozoa;  
 A: all parasites  
 B: the simplest animals  
 C: Autotrophs  
**D: unicellular organisms.**
18. By which one of the following processes does carbon dioxide pass through leaf stomata?  
 A: Osmosis              **B: Diffusion**              C: absorption              D: transpiration
19. Which of the following does not carry oxygen in blood of its body?  
**A: bee**              B: fish              C: snake              D: Earthworm  
 In bee (insect) oxygen is transported by the tracheal system
20. During a reflex action, the following takes place  
 1. impulse crosses the synapse  
 2. impulse passes along sensory neurone  
 3. receptors which are affected by a stimulus set up impulses  
 4. impulse passes along motor neurone to motor organ.

Which one of the following is the correct order?

- A: 1,2,3,4              **B: 3,2,1,4**              C: 2,3,4,1              D: 4,2,1,3

21. In an ecosystem, the organisms with the least energy in their bodies are  
 A: producers                      B: primary consumers  
 C: secondary consumers        **D: tertiary consumers**
22. Which of the following is found only in the fore limb of the mammalian skeleton?  
 A: Tibia              B: patella              **C: carpal**              D: metatarsal
23. Which of the letters on the diagram below represents the grey matter?

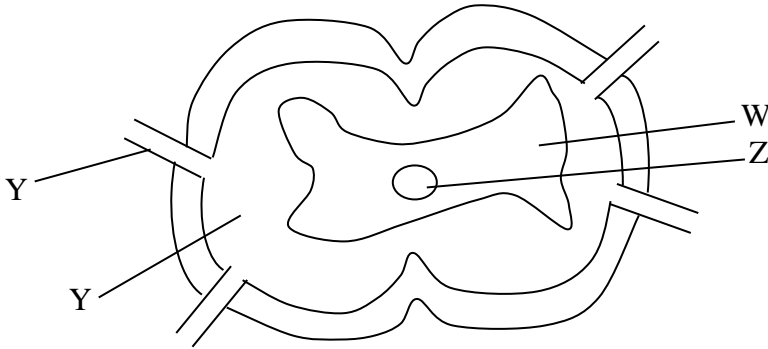

- A: W**                      B: X                      C: Y                      D: Z

24. What are the products of hydrolysis of maltose  
 A: Galactose and fructose                      B: Glucose and galactose  
**C: Glucose only**                      D: Glucose and fructose
25. Which of the following is an example of an endocrine gland in man?  
**A: Adrenal**                      B: Brain                      C: lymph node                      D: liver  
 Adrenal gland produce adrenaline
26. Which of the following types of feathers is most widespread?  
**A: convert feather**                      B: filloplumes  
 C: Quill feathers                      D: down feathers.
27. In which part of the green flowering plant does meiosis occur?  
 A: seed                      **B: flower**                      C: fruit                      D: shoot apex.
28. Short sightedness is caused by the  
**A: lens becoming thicker**                      B: suspensory ligament becoming shorter  
 C: contraction of the cilliary muscles                      D: expansion of the iris muscles.
29. Which of the following is true about nastic response?  
 A: depends on the direction of the stimulus  
 B: does not involve hormones.  
 C: the direction of a response is not determined by direction of stimulus  
**D: does not involve growth**
30. In an experiment to estimate the percentage of air in a sample of soil, a student poured 50 cm<sup>3</sup> of dry soil in measuring cylinder and then added 50 cm<sup>3</sup> of tap water. The final volume of soil and water was 75 cm<sup>3</sup>. What was the percentage of air in the sample?  
 A: 25%                      B: 40%                      C: 60%                      D: 75%

**SECTION B:**

31. In an experiment to investigate the effect of light intensity on the rate of photosynthesis, a shoot of the water weed *Elodea* was used. The shoot was immersed in a 2% sodium hydrogen carbonate solution in an apparatus which allowed for the collection of a gas given off from the shoot. The gas given off from the shoot was collected for 5 minutes at each light intensity and its volume measured. The results obtained at different light intensities (in arbitrary units) are shown in the table below.

Light intensity	Gas given off (evolved) cm <sup>3</sup> /5 minutes
1	0.35
2	0.60
3	0.85
5	1.20
10	1.55
20	1.70
30	1.80
40	1.80
50	1.80

- (a) Using the data given in the table above, plot a suitable graph of light intensity against the volume of gas evolved.

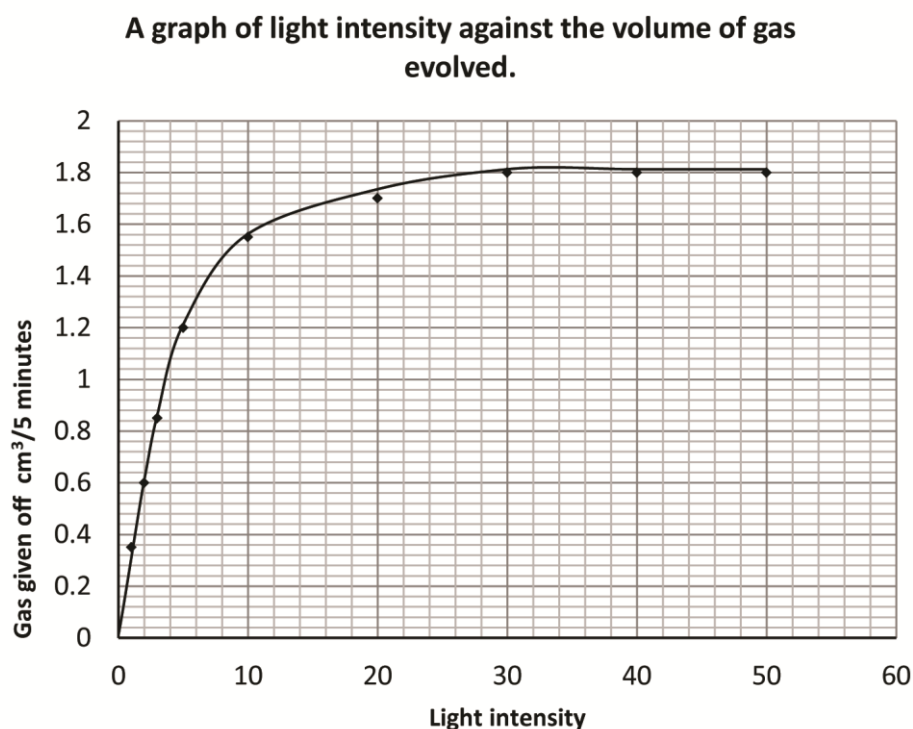

- (b) Describe and explain the rate of gas given off between 0 and 50 arbitrary units of light intensity.

The rate of evolution of a gas increases steeply with increase in light intensity between 0 and 10 units, then slowly up to 30 units and finally remains constant

- (c) State the amount of gas given off at 4 arbitrary unit.  
1cm<sup>3</sup>

- (d) What is the reason for using sodium hydrogen carbonate solution in this experiment.  
To provide carbon dioxide required for photosynthesis

32.

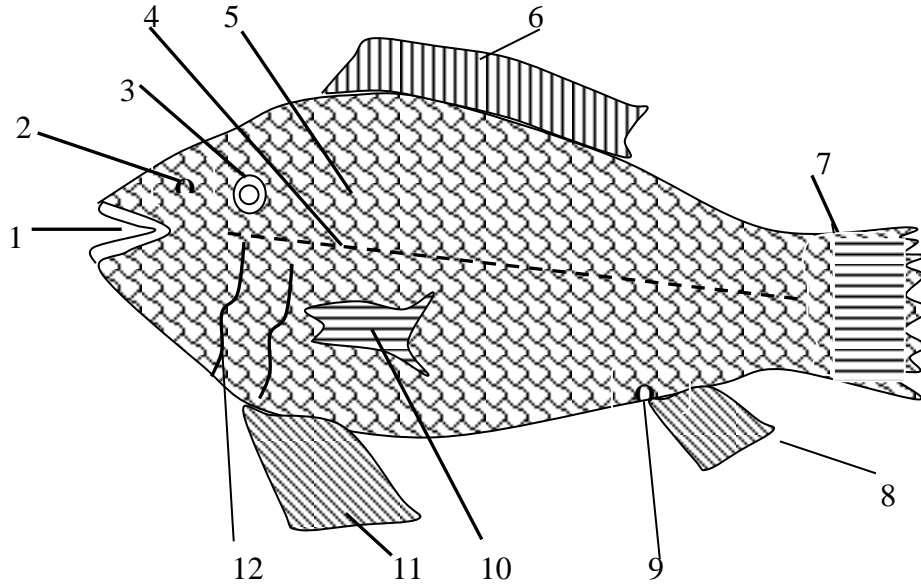

- (a) Label parts 1 to 12.

1. mouth
2. nostril
3. eye
4. lateral line
5. scale
6. dorsal fin
7. caudal fin
8. ventral fin
9. anus
10. pectoral fin
11. pelvic fin
12. Operculum/gill cover

- (b) What is the habitat of the fish above.  
water

- (c) What are the functions of the parts labelled 4, 7 and 10  
4 detects sound waves  
7 Provides propulsion force  
10 protects gills

(d) Explain two adaptive features for locomotion in the animal above

- Streamline shape reduces friction
- Eye to see in water
- Pectoral, pelvic and ventral fins for balancing.
- Slippery body reduce friction
- Has gills to extract oxygen from water
- swim bladders allow to maintains the proper buoyancy level

33. (a) Distinguish between the following terms

(i) Phenotype and Genotype

Phenotype is the physical characteristic of an organism determined by the genotype and the environment.

Genotype is the genetic constitution of an organism i.e. the particular set alleles, leading to observable characteristics

(ii) Dominant gene and Recessive gene

A dominant gene is the one that expresses itself entirely in heterozygous state while a recessive gene is one masked in heterozygous state

(b) A heterozygous tall man married a dwarf woman. The gene for tallness is dominant over that for dwarfness. Using suitable symbols, work out the proportions of the possible genotypes and phenotypes of their first filial generation.

Let T represent tallness

t represent shortness

Parents phenotype tall man x dwarf woman

Parents genotypes TT x tt

Gametes

T t

Offspring

Tt

Offspring phenotype

All tall

(c) Give three benefits of studying human genetics

- helps researchers develop new strategies to treat and prevent human disease.
- Help to understand more about the genetic basis of human diseases.
- Genetic engineering such as producing insulin for diabetic patients
- Use DNA sequencing to identify members of the family

**SECTION C:**

34. (a) What is locomotion?

It is the movement from one place to another

(b) Explain the adaptations of birds to flight

- Hollow bones reduce weight
- has feathers to insulate the body during flight
- a streamlined body – this helps reduce the force of drag
- wings – these enable the force of lift.
- Some of vertebral sections are fused together to provide the rigidity required for flight.
- The sternum provides a large surface area for the strong attachment of the main flight muscles.
- The size of the head has been reduced significantly when compared to other species. A large head would make flying more difficult.
- The tail has been reduced to a very short section of fused bones called the pygostyle (sometimes referred to as the Parson's nose or the Pope's nose).
- The ribs have been modified by the inclusion of the uncinat process which refers to overlying flaps projecting off the ribs connecting ribs to the ones beside them. This gives strength to the rib cage so that it will not collapse during flight.

35. (a) What is tropism?

Tropisms are growth responses towards or away from directional stimuli

(b) Describe an experiment to demonstrate hydrotropism in plant roots and shoots.

**Experiment to prove hydrotropism:****Procedure**

1. 1 and 2 beakers are taken.
2. Beaker 1 is filled with moist soil, which is used to sow the seeds.
3. In one part of beaker 2, dry soil is added, while in another section, moist soil is added, and the seeds are sown
4. Place a tiny beaker of water next to it as well.
5. Keep it for a while to allow the plants to flourish

**Result:**

1. It was discovered that in Beaker 1, plants will grow normally and roots will be straight due to the presence of moist soil.
2. The presence of the water beaker next to the plant in beaker 2 causes the plant to grow towards the water, as illustrated in the above illustration.

**Conclusion:**

1. As the roots bend towards the porous pot of water, it proves that the plant exhibits hydrotropism.
2. Hydrotropism is a type of plant growth response in which the direction of growth is regulated by a water concentration gradient stimulus.

Diagram



(c) Give two importance of tropism to plants

- Phototropism enables a plant to grow toward and obtain light for photosynthesis.
- Hydrotropism enable plant roots to grow towards and obtain water
- Geotropism is a growth response to gravity: it enable plant roots to grow into the soil to anchor the plant and to obtain water and the shoot to grow upright to receive light.
- Thigmotropism is a response to touch enable the plant leaves not to be eaten
- Chemotropism plant roots grow towards a region where they can obtain mineral salts and away from dangerous mineral.

36. (a) Explain the value of earthworms in maintaining a condition suitable for crop growing.

- Tunnels improve aeration and drainage of soil
- causes decay and formation of humus
- source of food to other animals e.g. chicken
- die and rot to form manure.
- Mixes soil layer

(b) How does clay affect the fertility of soil?

- Contain plant nutrients
- Increases soil capillarity
- Increase soil water retention
- Provide firm anchorage to the plants

37. (a) Name the constituents of the mammalian blood

**plasma, red blood cells, white blood cells, and platelets**, water, food nutrients (glucose, amino acids, fatty acids, vitamins), waste products (like urea and ammonia) hormones, antibodies

(b) Give three structural differences between an artery and a vein

**Differences between arteries and veins**

	Arteries	veins
1.	Thick wall	Thin walls
2.	Narrow lumen	Broad lumen

3.	Have no valves except pulmonary artery and aorta	Have valves
----	--	-------------

(c) What are the differences in blood contents between the bloods carried by hepatic portal vein and hepatic vein?

Blood in the hepatic portal vein is rich in nutrients from the intestine

END