



Dr. Bhasa Science

Sponsored by
The Science Foundation College
Uganda East Africa
Senior one to senior six

+256 778 633682 0753 143413

Based on, Best for Science

digitalteachers.co.ug



Nuture your dreams



Subsidiary Mathematics

SENIOR Six term 1

TOPIC 1/2: Probability Theory

Competency: The learner applies the knowledge of probability theory in predictions and decision-making processes.

Probability theory

Probability is the measure of chance of an event occurring or not occurring

Sample space

A sample space(s) is the set of all possible outcomes of an experiment

Example 1

When a dice is rolled once $s = (1, 2, 3, 4, 5, 6)$

When a coin is tossed once $s = (H, T)$

Events

An event (E) is a subset of a sample space.

Example2

When a coin is tossed twice, $s = (HH, TT, HT, TH)$

When interested in getting one head, $E = (TH, HT)$

Probability of an event

Given an event, E over a sample space, S

$$P(E) = \frac{n(E)}{n(S)}$$

Example 3

Find the probability of getting two heads when an ordinary coin is tossed thrice

$S = (HHH, HHT, HTH, HTT, THH, THT, TTH, TTT)$

$E = (HTH, HHT, THH)$

$$P(E) = \frac{n(E)}{n(S)} = \frac{3}{8}$$

Example 4

Find the probability of getting a number greater than 3 when ordinary die is tossed once

$S = (1, 2, 3, 4, 5, 6)$

$E = (4, 5, 6)$

$$P(E) = \frac{1}{3}$$

Intersection of events

For any two events A and B, the probability that A and B occur together is $(A \cap B)$

Union of event

For any two events A and B, the probability that event A or B or both occur is $P(A \cup B)$

$$P(A \cup B) = P(A) + P(B) - P(A \cap B)$$

$$P(A \text{ or } B) = P(A) + P(B) - P(A \text{ and } B)$$

Example 5

The probability that a student passes economics is $\frac{2}{3}$, the probability that he passes mathematics is $\frac{4}{9}$. If the probability that he passes at least one of them is $\frac{4}{5}$. Find the probability that he passes both subjects.

$$P(E \cup M) = P(E) + P(M) - P(E \cap M)$$

$$P(E \cap M) = \frac{2}{3} + \frac{4}{9} - \frac{4}{5} = \frac{14}{45}$$

Complement of events

A' denotes event A does not occur

For events A and B

(i) $P(A) + P(A') = 1$

(ii) $P(B) + P(B') = 1$

(iii) $P(A \cup B) + P(A \cup B)' = 1$

(iv) $P(A \cap B) + P(A \cap B)' = 1$

Venn diagram

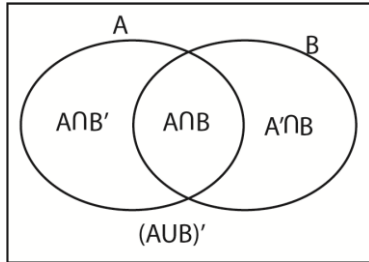

- (i) $P(A) = P(A \cap B') + P(A \cap B)$
 (ii) $P(B) = P(B \cap A') + P(A \cap B)$

Contingency table

	B	B'	
A	$P(A \cap B)$	$P(A \cap B')$	$P(A)$
A'	$P(A' \cap B)$	$P(A' \cap B')$	$P(A')$
	$P(B)$	$P(B')$	1

- (i) $P(A) = P(A \cap B) + P(A \cap B')$
 (ii) $P(A') = P(A' \cap B) + P(A' \cap B')$
 (iii) $P(B) = P(A \cap B) + P(A' \cap B)$
 (iv) $P(B') = P(A \cap B') + P(A' \cap B')$

Demorgan's rule

- (i) $P(A' \cap B') = P(A \cup B)' = 1 - P(A \cup B)$
 $P(\text{neither A nor B}) = 1 - P(A \cup B)$
 (ii) $P(A' \cup B') = P(A \cap B)' = 1 - P(A \cap B)$

Types of events

- Undefined events
- Mutual events
- Independent events
- Exhaustive events

Unidentified events

For unidentified events, there is no restriction on $P(A \cap B)$

Example 6

Event A and B are such that $P(A) = \frac{19}{30}$, $P(B) = \frac{2}{5}$ and $P(A \cup B) = \frac{4}{5}$ find

- (i) $P(A \cap B)$
 Using, $P(A \cup B) = P(A) + P(B) - P(A \cap B)$
 $P(A \cap B) = \frac{19}{30} + \frac{2}{5} - \frac{4}{5} = \frac{19+12-24}{30} = \frac{7}{30}$
- (ii) $P(A' \cap B')$
 Using, $P(A' \cap B') = P(A \cup B)' = 1 - P(A \cup B)$

$$P(A' \cap B') = 1 - \frac{4}{5} = \frac{1}{5}$$

(iii) $P(B \cap A')$
Using, $P(B) = P(B \cap A') + P(A \cap B)$

$$P(B \cap A') = \frac{2}{5} - \frac{7}{30} = \frac{5}{30} = \frac{1}{6}$$

(iv) $P(A' \cup B)$

$$P(A' \cup B) = P(A') + P(B) - P(A' \cap B)$$

$$= \left(1 - \frac{19}{30}\right) + \frac{2}{5} - \frac{1}{6} = \frac{3}{5}$$

(v) $P(A \cap B')$

$$P(A \cap B') = P(A) - P(A \cap B)$$

$$= \frac{19}{30} - \frac{7}{30} = \frac{12}{30} = \frac{2}{5}$$

Example 7

Event X and Y are such that $P(X) = 0.3$, $P(Y) = 0.4$ and $P(X \cap Y) = 0.1$, find

(i) $P(Y')$

$$P(Y') = 1 - P(Y) = 1 - 0.4 = 0.6$$

(ii) $P(X \cap Y')$

$$P(X \cap Y') = P(X) - P(X \cap Y) = 0.3 - 0.1 = 0.2$$

(iii) $P(X' \cap Y')$

$$P(X' \cap Y') = P(X') - P(X' \cap Y) = (1 - 0.3) - 0.3 = 0.4$$

(iv) $P(X' \cup Y')$

$$P(X' \cup Y') = P(X \cap Y)' = 1 - 0.1 = 0.9$$

Example 8

Events A and B are such that $P(A) = 0.4$, $P(A \cap B) = 0.1$ and $P(A \cup B) = 0.9$, find

(i) $P(B)$

$$P(A \cup B) = P(A) + P(B) - P(A \cap B)$$

$$0.9 = 0.4 + P(B) - 0.1$$

$$P(B) = 0.6$$

(ii) $P(A' \cap B)$

$$P(A' \cap B) = P(B) - P(A \cap B)$$

$$= 0.6 - 0.1$$

$$= 0.5$$

(iii) $P(A \cap B')$

$$P(A \cap B') = P(A) - P(A \cap B)$$

$$= 0.4 - 0.1$$

$$= 0.3$$

(iv) $P(A \cup B')$

$$P(A \cup B') = P(A) + P(B') - P(A \cap B')$$

$$= 0.4 + (1 - 0.6) - 0.3$$

$$= 0.5$$

Example 9

Events A and B are such that $P(A) = 0.7$, $P(A \cap B) = 0.45$ and $P(A' \cap B') = 0.18$, find

(i) $P(B')$
 $P(A') = P(A' \cap B) + P(A' \cap B')$

$$1 - 0.7 = P(A' \cap B) + 0.18$$

$$P(A' \cap B) = 0.3 - 0.18 = 0.12$$

$$P(B) = P(A' \cap B) + P(A \cap B)$$

$$1 - P(B') = 0.12 + 0.45$$

$$P(B') = 0.43$$

Alternatively

$$P(A' \cap B') = P(A \cup B)' = 1 - P(A \cup B)$$

$$1 - P(A \cup B) = 0.18$$

$$P(A \cup B) = 0.82$$

$$P(A \cup B) = P(A) + P(B) - P(A \cap B)$$

$$0.82 = 0.7 + P(B) - 0.43$$

$$P(B) = 0.57$$

$$P(B') = 1 - 0.57 = 0.43$$

(ii) $P(A \text{ or } B, \text{ but not both } A \text{ and } B)$

$$= P(A' \cap B) + P(A \cap B') = 0.12 + P(A) - P(A \cap B) = 0.12 + 0.7 - 0.45 = 0.37$$

Example 10

The probability that Anne reads the NewVision is 0.75 and the probability that she reads NewVision and bot Daily-monitor is 0.65. The probability that she reads neither of the papers is 0.15. Find the probability that she reads Daily-monitor.

$$P(N) = 0.75, P(N \cap D') = 0.65, P(N' \cap D') = 0.15$$

$$P(D') = P(N \cap D') + P(N' \cap D')$$

$$1 - P(D') = 0.65 + 0.15$$

$$P(D') = 0.2$$

Example 11

Event A and B are such that $P(A' \cap B) = 3x$, $P(A \cap B') = x$ and $P(B) = \frac{4}{7}$. Use a Venn diagram to find the value of

- (i) x
(ii) $P(A \cap B)$

Solution

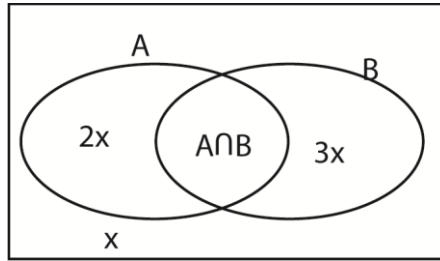

- (i) $P(A \cup B) = P(A \cap B') + P(B)$
 $1 - P(A \cup B)' = 2x + \frac{4}{7}$
 $1 - x = 2x + \frac{4}{7}$
 $x = \frac{1}{7}$
- (ii) $P(A \cap B) = P(B) - P(A' \cap B)$
 $= \frac{4}{7} - 3\left(\frac{1}{7}\right) = \frac{1}{7}$

Revision exercise 1

- Event C and D are such that $P(C) = 0.5$, $P(D) = 0.7$ and $P(C \cup D) = 0.8$, find
(i) $P(C \cap D)$
(ii) $P(C \cap D')$
- Events A and B are such that $P(A) = 0.36$, $P(B) = 0.25$ and $P(A' \cap B) = 0.24$. Find
(i) $P(A')$ (ii) $P(A \cap B)$ (iii) $P(A \cup B)$ (iv) $P(A \cap B')$ (v) $P(A' \cup B')$
- Events C and D are such that $P(C) = 0.7$, $P(C \cap D) = 0.3$ and $P(C \cup D) = 0.9$. Find
(i) $P(D)$, (ii) $P(C \cap D')$ (iii) $P(C' \cap D)$ (iv) $P(C' \cap D')$
- Events A and B are such that $P(A') = \frac{2}{3}$, $P(B) = \frac{1}{2}$ and $P(A \cap B) = \frac{1}{12}$. Find
(i) $P(A \cup B)$ (ii) $P(A \cap B')$
- Events A and B are such that $P(A) = \frac{2}{3}$, $P(A \cap B) = \frac{5}{12}$ and $P(A \cup B) = \frac{3}{4}$. Find
(i) $P(B)$ (ii) $P(A' \cap B)$
- Events A and B are such that $P(A) = P(B)$, $P(A \cap B) = 0.1$ and $P(A \cup B) = 0.7$. Find
(i) $P(A)$ (ii) $P(A' \cup B)$
- Event A and B are such that $P(A) = \frac{7}{12}$, $P(B) = \frac{3}{4}$ and $P(A \cap B) = \frac{2}{5}$. Find
(i) $P(A \cup B)$ (ii) $P(A \cap B')$

Solutions to Revision exercise 1

- Event C and D are such that $P(C) = 0.5$, $P(D) = 0.7$ and $P(C \cup D) = 0.8$, find
(i) $P(C \cap D)$
 $P(C \cup D) = P(C) + P(D) - P(C \cap D)$
 $0.8 = 0.5 + 0.7 - P(C \cap D)$
 $P(C \cap D) = 0.4$
(ii) $P(C \cap D')$

$$P(C) = P(C \cap D) + P(C \cap D')$$

$$P(C \cap D') = 0.5 - 0.4 = 0.1$$

2. Events A and B are such that $P(A) = 0.36$, $P(B) = 0.25$ and $P(A' \cap B) = 0.24$. Find

(i) $P(A') = 1 - P(A) = 1 - 0.36 = 0.64$

(ii) $P(A \cap B)$

$$P(B) = P(A \cap B) + P(A' \cap B)$$

$$P(A \cap B) = 0.25 - 0.24 = 0.01$$

(iii) $P(A \cup B)$

$$P(A \cup B) = P(A) + P(B) - P(A \cap B)$$

$$= 0.36 + 0.25 - 0.01 = 0.6$$

(iv) $P(A \cap B')$

$$P(A) = P(A \cap B) + P(A \cap B')$$

$$P(A \cap B') = 0.36 - 0.01 = 0.35$$

(v) $P(A' \cup B')$

$$P(A' \cup B') = P(A \cap B)' = 1 - P(A \cap B)$$

$$= 1 - 0.01 = 0.99$$

3. Events C and D are such that $P(C) = 0.7$, $P(C \cap D) = 0.3$ and $P(C \cup D) = 0.9$. Find

(i) $P(D)$

$$P(C \cup D) = P(C) + P(D) - P(C \cap D)$$

$$0.9 = 0.7 + P(D) - 0.3$$

$$P(D) = 0.5$$

(ii) $P(C \cap D')$

$$P(C) = P(C \cap D) + P(C \cap D')$$

$$P(C \cap D') = 0.7 - 0.3 = 0.4$$

(iii) $P(C' \cap D)$

$$P(D) = P(C \cap D) + P(C' \cap D)$$

$$P(C' \cap D) = 0.5 - 0.3 = 0.2$$

(iv) $P(C' \cap D')$

$$P(C' \cap D') = 1 - P(C \cup D) = 1 - 0.9 = 0.1$$

4. Events A and B are such that $P(A') = \frac{2}{3}$, $P(B) = \frac{1}{2}$ and $P(A \cap B) = \frac{1}{12}$. Find

(i) $P(A \cup B)$

$$P(A) = 1 - P(A') = 1 - \frac{2}{3} = \frac{1}{3}$$

$$P(A \cup B) = P(A) + P(B) - P(A \cap B) = \frac{1}{3} + \frac{1}{2} - \frac{1}{12} = \frac{9}{12} = \frac{3}{4} = 0.75$$

(ii) $P(A \cap B')$

$$P(A) = P(A \cap B) + P(A \cap B')$$

$$P(A \cap B') = \frac{1}{3} - \frac{1}{12} = \frac{3}{12} - \frac{1}{12} = \frac{2}{12} = \frac{1}{6} = 0.1667$$

5. Events A and B are such that $P(A) = \frac{2}{3}$, $P(A \cap B) = \frac{5}{12}$ and $P(A \cup B) = \frac{3}{4}$. Find

(i) $P(B)$

$$P(A \cup B) = P(A) + P(B) - P(A \cap B)$$

$$P(B) = \frac{3}{4} + \frac{5}{12} - \frac{2}{3} = \frac{6}{12} + \frac{5}{12} - \frac{8}{12} = \frac{3}{12} = \frac{1}{4} = 0.25$$

(ii) $P(A' \cap B)$

$$P(B) = P(A \cap B) + P(A' \cap B)$$

$$P(A' \cap B) = \frac{1}{4} - \frac{2}{12} = \frac{1}{12}$$

6. Events A and B are such that $P(A) = P(B)$, $P(A \cap B) = 0.1$ and $P(A \cup B) = 0.7$. Find

(i) $P(A)$

$$P(A \cup B) = P(A) + P(B) - P(A \cap B)$$

$$2P(A) = 0.7 + 0.1 = 0.8$$

$$P(A) = 0.4$$

(ii) $P(A' \cup B)$

$$P(A) = P(A \cap B) + P(A \cap B')$$

$$P(A \cap B') = 0.4 - 0.1 = 0.3$$

$$P(A \cup B') = P(B) + P(A') - P(A \cap B')$$

$$= 0.4 + (1 - 0.4) - 0.3$$

$$= 0.57$$

7. Event A and B are such that $P(A) = \frac{7}{12}$, $P(B) = \frac{3}{4}$ and $P(A \cap B) = \frac{2}{5}$. Find

(i) $P(A \cup B)$

$$P(A \cup B) = P(A) + P(B) - P(A \cap B)$$

$$= \frac{7}{12} + \frac{3}{4} - \frac{2}{5} = \frac{35}{60} + \frac{45}{60} - \frac{24}{60} = \frac{56}{60} = \frac{14}{15}$$

(ii) $P(A \cap B')$

$$P(A) = P(A \cap B) + P(A \cap B')$$

$$P(A \cap B') = \frac{7}{12} - \frac{2}{5} = \frac{35}{60} - \frac{24}{60} = \frac{11}{60}$$

Mutually exclusive events

Two events are mutually exclusive if they do not occur together i.e. $P(A \cap B) = 0$

$$P(A \cup B) = P(A) + P(B)$$

Example 12

Events A and B are mutually exclusive such that $P(B) = \frac{1}{2}$, $P(A) = \frac{2}{5}$, find

(i) $P(A \cup B)$

$$P(A \cup B) = P(A) + P(B) = \frac{1}{2} + \frac{2}{5} = \frac{9}{10} = 0.9$$

(ii) $P(A' \cap B)$

$$P(A' \cap B) = P(B) - P(A \cap B) = 0.5 - 0 = 0.5$$

(iii) $P(A' \cap B')$

$$P(A' \cap B') = P(A \cup B)' = 1 - P(A \cup B) = 1 - 0.9 = 0.1$$

Example 13

Event A and B are mutually exclusive such that $P(A \cup B) = \frac{7}{10}$, $P(A) = \frac{3}{5}$; find

- (i) $P(B)$
 $P(B) = P(A \cup B) + P(A \cap B) - P(A) = 0.7 + 0 - 0.6 = 0.1$
- (ii) $P(A' \cap B)$
 $P(B) = P(A \cap B) + P(A' \cap B)$
 $P(A' \cap B) = 0.1 - 0 = 0.1$
- (iii) $P(A \cap B')$
 $P(A) = P(A \cap B) + P(A \cap B')$
 $P(A \cap B') = 0.6 - 0 = 0.6$
- (iv) $P(A' \cap B')$
 $P(A' \cap B') = P(A \cup B)' = 1 - P(A \cup B) = 1 - 0.7 = 0.3$
- (v) $P(A' \cup B')$
 $P(A' \cup B') = P(A \cap B)' = 1 - P(A \cap B) = 1 - 0 = 1$
- (vi) $P(A \cup B')$
 $P(A \cup B') = P(A) + P(B') - P(A \cap B')$
 $= 0.6 + 1 - 0.1 - 0.6 = 0.9$
- (vii) $P(A' \cup B)$
 $P(A' \cup B) = P(B) + P(A') - P(A' \cap B)$
 $= 0.1 + 1 - 0.6 - 0.1 = 0.4$

Example 14

In an athletics competition in which there no dead heats, the probability that Kiplimo wins is 0.5, the probability that Bekele wins is 0.2, the probability that Cheptegei wins is 0.1.

Find the probability that

- (i) Bekele or Kiplimo wins
 $P(B \cup K) = P(B) + P(K) = 0.2 + 0.5 = 0.7$
- (ii) Neither Kiplimo nor Cheptegei wins
 $P(K' \cap B') = P(K \cup B)' = 1 - P(K \cup B) = 1 - (0.5 + 0.1) = 0.4$

Revision exercise B

1. Events A and B are mutually exclusive such that $P(A) = \frac{1}{2}$ and $P(B) = \frac{2}{5}$; find

- (i) $P(A \cup B)$ (ii) $P(A \cap B')$ (iii) $P(A' \cap B')$

2. Events A and B are mutually exclusive such that $P(B) = \frac{3}{10}$, $P(A) = \frac{3}{5}$; find

- (i) $P(A \cup B)$ (ii) $P(A')$ (iii) $P(A' \cap B)$

3. Events A and B are mutually exclusive such that $P(B) = 0.4$, $P(A) = 0.5$, find

- (i) $P(A' \cup B)$ (ii) $P(B')$ (iii) $P(A' \cap B')$

4. Events A and B are mutually exclusive such that $P(A \cup B) = \frac{8}{10}$, $P(A) = \frac{2}{5}$, find

(i) $P(B)$ (ii) $P(A' \cap B)$ (iii) $P(A \cap B')$ (iv) $P(A' \cap B')$ (v) $P(A \cup B')$ (vi) $P(A' \cup B)$

5. Events A and B are mutually exclusive such that $P(A' \cap B) = 0.3$, $P(A' \cup B) = 0.45$, find

(i) $P(B)$ (ii) $P(A)$ (iii) $P(A' \cap B)$ (iv) $P(A' \cap B')$ (v) $P(A \cup B')$ (vi) $P(A' \cup B)$

6. Event A and B are mutually exclusive such $P(A \cup B) = 0.9$, $P(A \cup B') = 0.6$, find

(i) $P(B)$ (ii) $P(A)$ (iii) $P(A' \cup B)$ (iv) $P(A' \cap B')$ (v) $P(A' \cup B')$

Solutions to exercise B

1. Events A and B are mutually exclusive such that $P(A) = \frac{1}{2}$ and $P(B) = \frac{2}{5}$; find

(i) $P(A \cup B) = P(A) + P(B) = \frac{1}{2} + \frac{2}{5} = \frac{9}{10} = 0.9$

(ii) $P(A \cap B') = P(A) - P(A \cap B) = 0.4 - 0 = 0.4$

(iii) $P(A' \cap B') = P(A \cup B)' = 1 - P(A \cup B) = 1 - 0.9 = 0.1$

2. Events A and B are mutually exclusive such that $P(B) = \frac{3}{10}$, $P(A) = \frac{3}{5}$, find

(i) $P(A \cup B) = P(A) + P(B) = \frac{3}{10} + \frac{3}{5} = \frac{9}{10} = 0.9$

(ii) $P(A') = 1 - P(A) = 1 - 0.6 = 0.4$

(iii) $P(A' \cap B) = P(B) - P(A \cap B) = 0.3 - 0 = 0.3$

3. Events A and B are mutually exclusive such that $P(B) = 0.4$, $P(A) = 0.5$, find

(i) $P(A' \cup B)$

$$\begin{aligned} P(A' \cup B) &= P(B) + P(A') - P(A' \cap B) \\ &= 0.4 + 1 - 0.5 - 0.4 = 0.5 \end{aligned}$$

(ii) $P(B') = 1 - P(B) = 1 - 0.4 = 0.6$

(iii) $P(A' \cap B') = P(A \cup B)' = 1 - P(A \cup B) = 1 - (P(A) + P(B)) = 1 - (0.4 + 0.5) = 0.1$

4. Events A and B are mutually exclusive such that $P(A \cup B) = \frac{8}{10}$, $P(A) = \frac{2}{5}$, find

(i) $P(B) = P(A \cup B) - P(A) = 0.8 - 0.4 = 0.4$

(ii) $P(A' \cap B) = P(B) - P(A \cap B) = 0.4 - 0 = 0.4$

(iii) $P(A \cap B') = P(A) - P(A \cap B) = 0.4 - 0 = 0.4$

(iv) $P(A' \cap B') = P(A \cup B)' = 1 - P(A \cup B) = 1 - 0.8 = 0.2$

$$(v) P(A \cup B') = P(A) + P(B') - P(A \cap B') = 0.6 + (1 - 0.4) - 0.4 = 0.6$$

$$(vi) P(A' \cup B) = P(A') + P(B) - P(A' \cap B) = (1 - 0.4) + 0.4 - 0.4 = 0.6$$

5. Events A and B are mutually exclusive such that $P(A' \cap B) = 0.3$, $P(A' \cup B) = 0.45$, find

$$(i) P(B) = P(A \cap B) + P(A' \cap B) = 0 + 0.3 = 0.3$$

$$(ii) P(A)$$

$$P(A' \cup B) = P(A') + P(B) - P(A' \cap B)$$

$$0.45 = P(A') + 0.3 - 0.3$$

$$P(A') = 0.45$$

$$P(A) = 1 - P(A') = 1 - 0.45 = 0.55$$

$$(iii) P(A' \cap B) = 0.55$$

$$P(B) = P(A \cap B) + P(A' \cap B)$$

$$P(A' \cap B) = P(B) - P(A \cap B) = 0.3 - 0 = 0.3$$

$$(iv) P(A' \cap B') = P(A \cup B)' = 1 - P(A \cup B) = 1 - (P(A) + P(B)) = 1 - (0.55 + 0.3) = 0.15$$

$$(v) P(A' \cup B') = P(A \cap B)' = 1 - P(A \cap B) = 1 - 0 = 1$$

$$(vi) P(A' \cup B) = P(A') + P(B) - P(A' \cap B)$$

$$= (1 - 0.55) + 0.3 - 0.3 = 0.45$$

6. Event A and B are mutually exclusive such $P(A \cup B) = 0.9$, $P(A \cup B') = 0.6$, find

$$(i) P(B) = 0.4$$

$$P(A) + P(B') - P(A \cap B') = 0.6$$

$$P(A) + [1 - P(B)] - P(A) = 0.6$$

$$1 - P(B) = 0.6$$

$$P(B) = 0.4$$

$$(ii) P(A) = 0.5$$

$$P(A) + P(B) = 0.9$$

$$P(A) = 0.9 - 0.4 = 0.5$$

$$(iii) P(A' \cup B) = P(A') + P(B) - P(A' \cap B)$$

$$= (1 - 0.5) + 0.4 - 0.4 = 0.5$$

$$(iv) P(A' \cap B') = P(A \cup B)' = 1 - P(A \cup B) = 1 - 0.9 = 0.1$$

$$(v) P(A' \cup B') = P(A \cap B)' = 1 - P(A \cap B) = 1 - 0 = 1$$

Independent event

Two events A and B are independent if the occurrence of one does not affect the other

- (i) $P(A \cap B) = P(A) \times P(B)$
- (ii) $P(A' \cap B) = P(A') \times P(B)$
- (iii) $P(A \cap B') = P(A) \times P(B')$
- (iv) $P(A' \cap B') = P(A') \times P(B')$

Example 15

Two independent events A and B are such that $P(A) = \frac{1}{4}$ and $P(B) = \frac{3}{5}$.

Find $P(A \cup B)$ (05marks)

$$P(A \cup B) = P(A) + P(B) - P(A \cap B)$$

$$= \frac{1}{4} + \frac{3}{5} - \frac{1}{4} \cdot \frac{3}{5}$$

$$= \frac{17}{20} - \frac{3}{20} = \frac{14}{20} = 0.7$$

Example 16

Events A and B are independent such that $P(A \cap B) = \frac{1}{12}$, $P(A) = \frac{1}{3}$, find

- (i) $P(B)$
 $P(A \cap B) = P(A) \times P(B)$
 $\frac{1}{12} = \frac{1}{3} \times P(B); P(B) = \frac{1}{4}$
- (ii) $P(A \cup B)$
 $P(A \cup B) = P(A) + P(B) - P(A \cap B) = \frac{1}{3} + \frac{1}{4} - \frac{1}{12} = 0.5$
- (iii) Show that A' and B are independent
 $P(A' \cap B) = P(B) - P(A \cap B)$
 $P(B) - P(A) \times P(B)$
 $= P(B)(1 - P(A))$
 $= P(A') \times P(B)$

Example 17

Events A and B are independent

- (i) Show that the events A and B' are also independent.
 $P(A \cap B') = P(A) - P(A \cap B)$
 $= P(A) - P(A) \times P(B)$
 $= P(A)(1 - P(B))$
 $= P(A) \times P(B')$
- (ii) Find $P(B)$ given that given that $P(A) = 0.4$ and $P(A \cup B) = 0.8$
 $P(A \cup B) = P(A) + P(B) - P(A \cap B)$

$$0.8 = 0.4 + y - 0.4y$$

$$0.6y = 0.4$$

$$y = \frac{0.4}{0.6} = \frac{2}{3}$$

Example 17

Events A and B are independent such that $P(A \cup B') = \frac{9}{10}$, $P(A) = \frac{2}{5}$, find

- (i) $P(B)$
 $P(A \cup B') = P(A) + P(B') - P(A \cap B')$
 $0.9 = 0.4 + (1-y) - 0.4(1-y) = 0.4 + 1 - y - 0.4 + 0.4y = 1 - 0.6y$
 $0.6y = 0.1$
 $y = \frac{0.1}{0.6} = \frac{1}{6}$
- (ii) $P(A \cup B)$
 $P(A \cup B) = P(A) + P(B) - P(A \cap B) = \frac{2}{5} + \frac{1}{6} - \frac{2}{5} \times \frac{1}{6} = \frac{12+5-2}{30} = \frac{15}{30} = 0.5$
- (iii) Show that A' and B' are independent
 $P(A' \cap B') = 1 - P(A \cup B)$
 $= 1 - [P(A) + P(B) - P(A) \times P(B)]$
 $= 1 - [P(A) + P(B) (1 - P(A))]$
 $= 1 - P(A) - P(B) \times P(A')$
 $= P(A') - P(B) \times P(A')$
 $= P(A') [1 - P(B)]$
 $= P(A') \times P(B')$

Example 18

The probability of two independent events A and B occurring together is $\frac{1}{8}$. The probability that either or both events occur is $\frac{5}{8}$. Find

- (i) $P(A)$
(ii) $P(B)$

Solution

Given $P(A \cup B) = \frac{5}{8}$ and $P(A \cap B) = \frac{1}{8}$

Let $P(A) = x$ and $P(B) = y$

$$x + y - xy = \frac{5}{8} \dots (i)$$

$$xy = \frac{1}{8}$$

$$x = \frac{1}{8y} \dots (ii)$$

(i) and (ii)

$$\frac{1}{8y} + y - \frac{1}{8} = \frac{5}{8}$$

$$\frac{1}{8y} + y = \frac{6}{8}$$

Multiplying through by 8y

$$1 + 8y^2 = 6y$$

$$8y^2 - 6y + 1 = 0$$

Using quadratic equation

$$y = \frac{6 \pm \sqrt{(-6)^2 - 4(8)(1)}}{2(8)} = \frac{6 \pm 2}{16}$$

$$\text{Either } y = \frac{8}{16} = 0.5 \text{ Or } y = \frac{4}{16} = \frac{1}{4} = 0.25$$

$$\text{When } y = 0.5; x = \frac{1}{8 \times 0.5} = 0.25$$

$$\text{When } y = 0.25; x = \frac{1}{8 \times 0.25} = 0.5$$

Hence $P(A) = 0.25$ and $P(B) = 0.5$ or $P(A) = 0.5$ and $P(B) = 0.25$

Example 19

Abel, Bob and Charles applied for the same job in a certain company. The probability that Abel will take the job is $\frac{3}{4}$, the probability that Bob takes it is $\frac{1}{2}$ while the probability that Charles will take the job is $\frac{2}{3}$; what is the probability that

(i) None of them will take the job

$$P(\text{none takes it}) = P(A' \cap B' \cap C') = P(A') \times P(B') \times P(C') = \frac{1}{4} \times \frac{1}{2} \times \frac{1}{3} = \frac{1}{24}$$

(ii) (one takes)

$$P(\text{one takes it}) = P(A \cap B' \cap C') + P(A' \cap B \cap C') + P(A' \cap B' \cap C) \\ \left(\frac{3}{4} \times \frac{1}{2} \times \frac{1}{3}\right) + \left(\frac{1}{4} \times \frac{1}{2} \times \frac{1}{3}\right) + \left(\frac{1}{4} \times \frac{1}{2} \times \frac{2}{3}\right) = \frac{1}{4}$$

Revision exercise C

- Events A and B are independent such that $P(A) = 0.4$, $P(B) = 0.25$. Find
(i) $P(A \cap B)$ (ii) $P(A \cap B')$ (iii) $P(A' \cap B')$
- Events A and B are independent such that $P(A) = 0.3$, $P(B) = 0.5$. Find
(i) $P(A \cap B)$ (ii) $P(A \cup B)$ (iii) $P(A' \cap B')$
- Events A and B are independent such that $P(A) = 0.4$, $P(A \cup B) = 0.7$ Find
(i) $P(B)$ (ii) $P(A \cap B)$ (iii) $P(A' \cap B)$
- Events A and B are independent such that $P(A) = \frac{1}{3}$, $P(B) = \frac{3}{4}$. Find the probability that
(i) Both occur

- (ii) Only one occurs
5. The probability that two independent events A and B occur together = $\frac{2}{15}$ and the probability that either A or B or both occur is $\frac{3}{5}$. Find
- (i) P(A) (ii) P(B)
6. A mother and her daughter both enter a competition. The probability that a mother wins a prize = $\frac{1}{6}$ and the probability that her daughter wins the prize is $\frac{2}{7}$. Assuming that the two events are independent, find the probability that
- (i) Either the mother or the daughter but not both wins the prize
(ii) At least one of them wins the prize
7. Two athletes, Kiprotich and Chebet attempt to qualify for Olympics games. The probability of Kiprotich qualifying is 0.8 and the probability that both Kiprotich and Chebet qualifying is 0.6. given that the probability of the athletes qualifying are independent events, find the probability that only one qualifies
8. The probability of two independent events A and B occurring together = $\frac{1}{10}$. The probability that either or both events occur is $\frac{8}{10}$. Find
- (i) P(A)
(ii) P(B)
9. The probability that a certain types of computer will break down on the first month of use = 0.1. If the school has two such computer bought at the same time, find the probability that at the end of the first month just one has broken. Assume that the performance of the two computers are independent
10. Three athletes enter a marathon race. The respective probabilities of them completing the race are 0.9, 0.7 and 0.6. assuming that their performance are independent, find the probability that
- (i) they all complete the race
(ii) at least two complete the race
11. The probability that two twins pass an interview are $\frac{1}{3}$ and $\frac{2}{5}$. Assuming that their performance are independent, find the probability
- (i) They all pass the interview
(ii) Only one passes the interview
12. The probability that Angela can solve a certain number is 0.4 and the probability that Jane can solve the same number is 0.5, find the probability the number will be solved if both students try the number independently
13. Three target men take part in a shooting competition, their chances of hitting the target are $\frac{1}{4}, \frac{1}{3}$ and $\frac{1}{2}$. Assuming that their performance are independent, find the probability that
- (i) Only one will hit the target
(ii) Target will be hit
14. Three football teams Noa, Kitende and Budo are playing in Nationals. The probability that Noa, Kitende and Budo qualify for the finals is $\frac{2}{3}, \frac{3}{5}$ and $\frac{1}{4}$. Find the probability that only two teams will qualify for the finals

15. Three Athletes Kiprop, Chebet and Aloysius are competing for a place in Olympics games. The probability that Kiprop, Chebet and Aloysius will qualify for the Olympics games is $\frac{2}{3}$, $\frac{2}{5}$ and $\frac{5}{6}$. Find the probability that only one athlete will qualify for the Olympics games .
16. The probability that three girls Faith, Jane and Angela will pass exams is $\frac{2}{3}$, $\frac{2}{5}$ and $\frac{3}{4}$ respectively. Find the probability that
- All the three will fail
 - All the three will pass
 - Only two will pass
17. The interview involves written, oral and practical tests. The probability than an interviewee passes written = 0.8, oral is 0.6 and practical is 0.7. what is the probability that the interviewee will pass
- The entire interview
 - Exactly two of the interview test
18. The probabilities that the players A, B and C score in a netball game are $\frac{1}{5}$, $\frac{1}{4}$ and $\frac{1}{3}$ respectively. If the player play together in a game, find the probability that
- Only one score
 - At least one player scores
 - Two and only two player score
19. Events a and B are such that $P(A) = \frac{1}{5}$, $P(B) = \frac{1}{2}$. Find $P(A \cup B)$ when A and B are
- Independent events
 - Mutually exclusive events

Solutions to revision exercise C

- Events A and B are independent such that $P(A) = 0.4$, $P(B) = 0.25$. Find
 - $P(A \cap B) = P(A) \times P(B) = 0.4 \times 0.25 = 0.1$
 - $P(A \cap B') = P(A) \times P(B') = 0.4 \times 0.75 = 0.3$
 - $P(A' \cap B') = P(A') \times P(B') = 0.6 \times 0.75 = 0.45$
- Events A and B are independent such that $P(A) = 0.3$, $P(B) = 0.5$. Find
 - $P(A \cap B) = P(A) \times P(B) = 0.3 \times 0.5 = 0.15$
 - $P(A \cup B) = P(A) + P(B) - P(A \cap B) = 0.3 + 0.5 - 0.15 = 0.65$
 - $P(A' \cap B') = 1 - P(A \cup B) = 1 - 0.65 = 0.35$
- Events A and B are independent such that $P(A) = 0.4$, $P(A \cup B) = 0.7$ Find
 - $P(B)$
 $P(A \cup B) = P(A) + P(B) - P(A) \times P(B)$
 $0.7 = 0.4 + x - 0.4x$
 $0.6x = 0.3$
 $x = 0.5$
 hence $P(B) = 0.5$
 - $P(A \cap B) = P(A) \times P(B) = 0.4 \times 0.5 = 0.2$
 - $P(A' \cap B) = 1 - P(A \cup B) = 1 - 0.7 = 0.3$
- Events A and B are independent such that $P(A) = \frac{1}{3}$, $P(B) = \frac{3}{4}$. Find the probability that
 - Both occur

$$P(A \cap B) = P(A) \times P(B) = \frac{1}{3} \times \frac{3}{4} = \frac{1}{4}$$

(ii) Only one occurs

$$P(A \cap B') + P(A' \cap B) = P(A) \times P(B') + P(A') \times P(B) = \frac{2}{3} \times \frac{3}{4} + \frac{1}{3} \times \frac{1}{4} = \frac{7}{12}$$

5. The probability that two independent events A and B occur together = $\frac{2}{15}$ and the probability that either A or B or both occur is $\frac{3}{5}$. Find

Let the $P(A) = x$ and $P(B) = y$

$$xy = \frac{2}{15} \dots\dots (i)$$

$$x + y - xy = \frac{3}{5} \dots\dots (ii)$$

Eqn (i) and eqn. (ii)

$$\frac{2}{15y} + y - \frac{2}{15} = \frac{3}{5}$$

$$2 + 15y^2 - 2y = 9y$$

$$15y^2 - 11y + 2 = 0$$

Using quadratic equation

$$y = \frac{11 \pm \sqrt{(-11)^2 - 4(15)(2)}}{2(15)} = \frac{11 \pm 1}{30}$$

$$y = \frac{10}{30} = \frac{1}{3} \text{ Or } y = \frac{12}{30} = 0.4$$

Either $P(A) = 0.4$ and $P(B) = \frac{1}{3}$ or $P(A) = \frac{1}{3}$ and $P(B) = 0.4$

6. A mother and her daughter both enter a competition. The probability that a mother wins a prize = $\frac{1}{6}$ and the probability that her daughter wins the prize is $\frac{2}{7}$. Assuming that the two events are independent, find the probability that

(i) Either the mother or the daughter but not both wins the prize = $\frac{5}{14}$

$$P(M \cap D') + P(M' \cap D) = P(M) \times P(D') + P(M') \times P(D) = \frac{1}{6} \times \frac{5}{7} + \frac{5}{6} \times \frac{2}{7} = \frac{15}{42} = \frac{5}{14}$$

(ii) At least one of them wins the prize

$$P(A \cup B) = P(A) + P(B) - P(A \cap B) = \frac{1}{6} + \frac{2}{7} - \frac{1}{6} \times \frac{2}{7} = \frac{17}{42}$$

7. Two athletes, Kiprotich and Chebet attempt to qualify for Olympics games. The probability of Kiprotich qualifying is 0.8 and the probability that both Kiprotich and Chebet qualifying is 0.6. given that the probability of the athletes qualifying are independent events, find the probability that only one qualifies = 0.35

$$P(K \cap B) = P(K) \times P(C) = 0.8 \times P(C) = 0.6$$

$$P(C) = \frac{0.6}{0.8} = \frac{3}{4}$$

$$P(K \cap C') + P(K' \cap C) = 0.8 \times 0.25 + 0.2 \times 0.75 = 0.35$$

8. The probability of two independent events A and B occurring together = $\frac{1}{10}$. The probability that either or both events occur is $\frac{8}{10}$. Find

(iii) $P(A)$

(iv) $P(B)$

Solution

Let the $P(A) = x$ and $P(B) = y$

$$xy = \frac{1}{10} \dots\dots (i)$$

$$x + y - xy = \frac{8}{10} \dots\dots (ii)$$

Eqn (i) and eqn. (ii)

$$\frac{1}{10y} + y - \frac{1}{10} = \frac{8}{10}$$

$$1 + 10y^2 - y = 8y$$

$$10y^2 - 9y + 1 = 0$$

Using quadratic equation

$$y = \frac{9 \pm \sqrt{(-9)^2 - 4(10)(1)}}{2(10)} = \frac{9 \pm 6.4}{20}$$

$$y = \frac{2.6}{20} = 0.13 \text{ Or } y = \frac{12}{20} = 0.6$$

Either $P(A) = 0.13$ and $P(B) = 0.6$ or $P(A) = 0.6$ and $P(B) = 0.13$

9. The probability that a certain types of computer will break down on the first month of use = 0.1. If the school has two such computer bought at the same time, find the probability that at the end of the first month just one has broken. Assume that the performance of the two computers are independent = 0.18

Let the computers be A and B

$$\begin{aligned} P(\text{one has broken down}) &= P(A \cap B') + P(A' \cap B) \\ &= 0.1 \times 0.9 + 0.9 \times 0.1 \\ &= 0.18 \end{aligned}$$

10. Three athletes enter a marathon race. The respective probabilities of them completing the race are 0.9, 0.7 and 0.6. Assuming that their performance are independent, find the probability that

- (i) they all complete the race

Let the athletes be A, B, C

$$P(\text{all complete the race}) = P(A \cap B \cap C) = 0.9 \times 0.7 \times 0.6 = 0.378$$

- (ii) at least two complete the race

$$\begin{aligned} P(\text{At least two complete the race}) &= P(A' \cap B \cap C) + P(A \cap B' \cap C) + P(A \cap B \cap C') + P(A \cap B \cap C) \\ &= 0.1 \times 0.7 \times 0.6 + 0.9 \times 0.3 \times 0.6 + 0.9 \times 0.7 \times 0.4 + 0.378 \\ &= 0.834 \end{aligned}$$

11. The probability that two twins pass an interview are $\frac{1}{3}$ and $\frac{2}{5}$. Assuming that their performance are independent, find the probability

- (i) They all pass the interview

Let the twins be A and B

$$P(\text{all pass}) = P(A \cap B) = \frac{1}{3} \times \frac{2}{5} = \frac{2}{15}$$

- (ii) Only one passes the interview

$$P(A \cap B') + P(A' \cap B) = \frac{2}{3} \times \frac{2}{5} + \frac{1}{3} \times \frac{3}{5} = \frac{7}{15}$$

12. The probability that Angela can solve a certain number is 0.4 and the probability that Jane can solve the same number is 0.5, find the probability the number will be solved if both students try the number independently = 0.7

$$\begin{aligned}
P(\text{the number solved}) &= P(A \cap J') + P(A' \cap J) + P(A \cap J) \\
&= 0.4 \times 0.5 + 0.6 \times 0.5 + 0.4 \times 0.5 \\
&= 0.7
\end{aligned}$$

13. Three target men take part in a shooting competition, their chances of hitting the target are $\frac{1}{4}$, $\frac{1}{3}$ and $\frac{1}{2}$. Assuming that their performance are independent, find the probability that

Let the men be A, B and V

- (i) Only one will hit the target =

$$\begin{aligned}
P(\text{one hit the target}) &= P(A' \cap B' \cap C) + P(A' \cap B \cap C') + P(A \cap B' \cap C') \\
&= \frac{3}{4} \times \frac{2}{3} \times \frac{1}{2} + \frac{3}{4} \times \frac{1}{3} \times \frac{1}{2} + \frac{1}{4} \times \frac{2}{3} \times \frac{1}{2} \\
&= \frac{11}{24}
\end{aligned}$$

- (ii) Target will be hit

$$\begin{aligned}
P(\text{target hit}) &= P(A' \cap B' \cap C) + P(A' \cap B \cap C') + P(A \cap B' \cap C') + P(A' \cap B \cap C) + P(A \cap B \cap C') + \\
&\quad P(A \cap B' \cap C) + P(A \cap B \cap C) \\
&= \frac{11}{24} + \frac{3}{4} \times \frac{1}{3} \times \frac{1}{2} + \frac{1}{4} \times \frac{1}{3} \times \frac{1}{2} + \frac{1}{4} \times \frac{2}{3} \times \frac{1}{2} + \frac{1}{4} \times \frac{1}{3} \times \frac{1}{2} \\
&= \frac{18}{24} = 0.75
\end{aligned}$$

14. Three football teams Noa, Kitende and Budo are playing in Nationals. The probability that Noa, Kitende and Budo qualify for the finals is $\frac{2}{3}$, $\frac{3}{5}$ and $\frac{1}{4}$. Find the probability that only two teams will qualify for the finals

$$\begin{aligned}
P(\text{only two teams qualify}) &= P(N' \cap K \cap B) + P(N \cap K' \cap B) + P(N \cap K \cap B') \\
&= \frac{1}{3} \times \frac{3}{5} \times \frac{1}{4} + \frac{2}{3} \times \frac{2}{5} \times \frac{1}{4} + \frac{2}{3} \times \frac{3}{5} \times \frac{3}{4} \\
&= \frac{25}{60} = \frac{5}{12}
\end{aligned}$$

15. Three Athletes Kiprop, Chebet and Aloysius are competing for a place in Olympics games. The probability that Kiprop, Chebet and Aloysius will qualify for the Olympics games is $\frac{2}{3}$, $\frac{2}{5}$ and $\frac{5}{6}$. Find the probability that only one athlete will qualify for the Olympics games .

$$\begin{aligned}
P(\text{only one qualifies}) &= P(K \cap C' \cap A') + P(K' \cap C \cap A') + P(K' \cap C' \cap A) \\
&= \frac{2}{3} \times \frac{3}{5} \times \frac{1}{6} + \frac{1}{3} \times \frac{2}{5} \times \frac{1}{6} + \frac{1}{3} \times \frac{3}{5} \times \frac{5}{6} \\
&= \frac{23}{90}
\end{aligned}$$

16. The probability that three girls Faith, Jane and Angela will pass exams is $\frac{2}{3}$, $\frac{2}{5}$ and $\frac{3}{4}$ respectively.

Find the probability that

- (i) All the three will fail

$$P(\text{all fail}) = P(F' \cap J' \cap A') = \frac{1}{3} \times \frac{3}{5} \times \frac{1}{4} = \frac{1}{20}$$

- (ii) All the three will pass

$$P(\text{all pass}) = P(F \cap J \cap A) = \frac{2}{3} \times \frac{2}{5} \times \frac{3}{4} = \frac{1}{5}$$

- (iii) Only two will pass

$$\begin{aligned}
P(\text{only two pass}) &= P(F' \cap J \cap A) + P(F \cap J \cap A') + P(F \cap J' \cap A) \\
&= \frac{1}{3} \times \frac{2}{5} \times \frac{3}{4} + \frac{2}{3} \times \frac{2}{5} \times \frac{1}{4} + \frac{2}{3} \times \frac{3}{5} \times \frac{3}{4} = \frac{28}{60} = \frac{7}{15}
\end{aligned}$$

17. The interview involves written, oral and practical tests. The probability than an interviewee passes written = 0.8, oral is 0.6 and practical is 0.7. what is the probability that the interviewee will pass

(i) The entire interview

$$P(\text{pass entire interview}) = P(W \cap O \cap P) = 0.8 \times 0.6 \times 0.7 = 0.336$$

(ii) Exactly two of the interview test

$$\begin{aligned} P(\text{pass exactly two}) &= P(W' \cap O \cap P) + P(W \cap O' \cap P) + P(W \cap O \cap P') \\ &= 0.2 \times 0.6 \times 0.7 + 0.8 \times 0.4 \times 0.7 + 0.8 \times 0.6 \times 0.3 \\ &= 0.452 \end{aligned}$$

18. The probabilities that the players A, B and C score in a netball game are $\frac{1}{5}, \frac{1}{4}$ and $\frac{1}{3}$ respectively. If the player play together in a game, find the probability that

(i) Only one score

$$\begin{aligned} P(\text{only one scores}) &= P(A \cap B' \cap C') + P(A' \cap B \cap C') + P(A' \cap B' \cap C) \\ &= \frac{1}{5} \times \frac{3}{4} \times \frac{2}{3} + \frac{4}{5} \times \frac{1}{4} \times \frac{2}{3} + \frac{4}{5} \times \frac{3}{4} \times \frac{1}{3} = \frac{26}{60} = \frac{13}{30} \end{aligned}$$

(ii) At least one player scores

$$\begin{aligned} P(\text{at least one scores}) &= P(A \cap B' \cap C') + P(A' \cap B \cap C') + P(A' \cap B' \cap C) + P(A \cap B \cap C') + \\ &\quad P(A' \cap B \cap C) + P(A \cap B' \cap C) + P(A \cap B \cap C) \\ &= \frac{13}{30} + \frac{1}{5} \times \frac{1}{4} \times \frac{2}{3} + \frac{4}{5} \times \frac{1}{4} \times \frac{1}{3} + \frac{1}{5} \times \frac{3}{4} \times \frac{1}{3} + \frac{1}{5} \times \frac{1}{4} \times \frac{1}{3} \\ &= \frac{36}{60} = \frac{3}{5} \end{aligned}$$

(iii) Two and only two player score

$$\begin{aligned} &= P(A \cap B \cap C') + P(A' \cap B \cap C) + P(A \cap B' \cap C) \\ &= \frac{1}{5} \times \frac{1}{4} \times \frac{2}{3} + \frac{4}{5} \times \frac{1}{4} \times \frac{1}{3} + \frac{1}{5} \times \frac{3}{4} \times \frac{1}{3} \\ &= \frac{9}{60} = \frac{3}{20} \end{aligned}$$

19. Events a and B are such that $P(A) = \frac{1}{5}$, $P(B) = \frac{1}{2}$. Find $P(A \cup B)$ when A and B are

(i) Independent events

$$P(A \cup B) = P(A) + P(B) - P(A \cap B) = \frac{1}{5} + \frac{1}{2} - \frac{1}{5} \times \frac{1}{2} = \frac{6}{10} = \frac{3}{5}$$

(ii) Mutually exclusive events = $\frac{7}{10}$

$$P(A \cup B) = P(A) + P(B) - P(A \cap B) = \frac{1}{5} + \frac{1}{2} - 0 = \frac{7}{10}$$

Conditional probability

If A and B are two events, then the conditional probability that A occurs given that B has already occurred is $P(A/B)$

$$P(A/B) = \frac{P(A \cap B)}{P(B)}$$

Example 20

Events A and B are such that $P(A) = \frac{1}{5}$, $P(B) = \frac{1}{4}$ and $P(A/B) = \frac{2}{5}$. Find

(i) $P(A \cap B)$

$$P(A/B) = \frac{P(A \cap B)}{P(B)}$$

$$P(A \cap B) = \frac{2}{5} \times \frac{1}{4} = \frac{2}{20} = 0.1$$

- (ii) $P(A \cup B)$
 $P(A \cup B) = P(A) + P(B) - P(A \cap B) = \frac{1}{5} + \frac{1}{4} - 0.1 = 0.35$
- (iii) $P(B/A)$
 $P(B/A) = \frac{P(A \cap B)}{P(A)} = \frac{0.1}{0.2} = 0.5$

Example 21

Events A and B are such that $P(A) = \frac{4}{7}$, $P(A \cap B') = \frac{1}{3}$ and $P(A/B) = \frac{5}{14}$. Find

- (i) $P(A \cap B)$
 $P(A \cap B) = P(A) - P(A \cap B') = \frac{4}{7} - \frac{1}{3} = \frac{12-7}{21} = \frac{5}{21}$
- (ii) $P(B)$
 $P(A/B) = \frac{P(A \cap B)}{P(B)}$
 $P(B) = \frac{5}{21} \div \frac{5}{14} = \frac{5}{21} \times \frac{14}{5} = \frac{2}{3}$
- (iii) $P(A \cup B)$
 $P(A \cup B) = P(A) + P(B) - P(A \cap B) = \frac{4}{7} + \frac{2}{3} - \frac{5}{21} = 1$

Example 22

Three A, B and C are such that $P(A) = 0.6$, $P(B) = 0.8$, $P(B/A) = 0.45$ and $P(B \cap C) = 0.28$. Find

(a) $P(A \cap B)$ (03 marks)

$$P(A \cap B) = P(B/A) \cdot P(A) = 0.45 \times 0.6 = 0.27$$

(b) $P(C/B)$ (02 marks)

$$P(C/B) = \frac{P(B \cap C)}{P(B)} = \frac{0.28}{0.8} = 0.35$$

Example 23

Events A and B are independent. Given that $P(A \cap B') = \frac{1}{4}$ and $P(A'/B) = \frac{1}{6}$. Find

- (i) $P(A)$
 $P(A'/B) = \frac{P(A' \cap B)}{P(B)} = \frac{P(A') \times P(B)}{P(B)}$
 $P(A') = \frac{1}{6}$ and $P(A) = 1 - \frac{1}{6} = \frac{5}{6}$
- (ii) $P(B)$
 $P(A \cap B') = P(A) \times P(B') =$

$$P(B') = P(A \cap B') \div P(A) = \frac{1}{4} \div \frac{5}{6} = \frac{1}{4} \times \frac{6}{5} = \frac{3}{10}$$

$$P(B) = 1 - P(B') = 1 - 0.3 = 0.7$$

(iii) $P(A \cap B) = P(A) \times P(B) = \frac{5}{6} \times \frac{7}{10} = \frac{7}{12}$

(iv) $P(A \cup B)'$

$$P(A \cup B) = P(A) + P(B) - P(A \cap B) = \frac{5}{6} + \frac{7}{10} - \frac{7}{12} = \frac{19}{20}$$

$$P(A \cup B)' = 1 - P(A \cup B) = 1 - \frac{19}{20} = \frac{1}{20}$$

Example 24

Events A and B are such that $P(A) = \frac{6}{13}$, $P(B) = \frac{2}{5}$ and $P(A/B) = \frac{1}{4}$

Find:

(a) $P(A \cap B)$ (02marks)

$$P(A \cap B) = P(B) \cdot P(A/B) = \frac{2}{5} \cdot \frac{1}{4} = \frac{1}{10}$$

(a) $P(A \cup B)$ (03marks)

$$P(A \cup B) = P(A) + P(B) - P(A \cap B) = \frac{6}{13} + \frac{2}{5} - \frac{1}{10} = \frac{99}{130}$$

Revision exercise D

- Events X and Y are such that $P(X') = \frac{3}{5}$, $P(Y/X') = \frac{1}{3}$ and $P(Y'/X) = \frac{1}{4}$. Find
 - $P(Y) = \frac{1}{2}$
 - $P(X'/Y)$
- Events A and B are such that $P(A) = \frac{2}{5}$, $P(A/B) = \frac{1}{2}$, $P(B/A) = \frac{2}{3}$. Find
 - $P(A \cap B) = \frac{4}{15}$
 - $P(B) = \frac{8}{15}$
 - $P(A \cup B) = \frac{2}{3}$
- Events A and B are such that $P(A) = \frac{1}{3}$, $P(B/A) = \frac{1}{4}$ and $P(B'/A') = \frac{4}{5}$. Find
 - $P(B'/A) = \frac{3}{4}$
 - $P(A \cap B) = \frac{1}{12}$
 - $P(B) = \frac{13}{60}$
 - $P(A \cup B) = \frac{7}{15}$
- Events A and B are such that $P(A) = \frac{1}{2}$, $P(B) = \frac{1}{3}$ and $P(A \cap B') = \frac{1}{3}$. Find
 - $P(A' \cup B') = \frac{5}{6}$
 - $P(A'/B') = \frac{1}{2}$
- Events A and B are such that $P(A \cap B) = \frac{1}{12}$, $P(B/A) = \frac{1}{3}$ and $P(B) = \frac{1}{6}$. Find
 - $P(A) = \frac{1}{4}$
 - $P(A/B) = \frac{1}{2}$
 - $P(A/B') = \frac{1}{5}$
- Events A and B are such that $P(A \cup B) = 0.8$, $P(A/B) = 0.2$ and $P(A' \cap B') = 0.4$. Find
 - $P(A \cap B) = 0.1$
 - $P(B) = 0.5$
 - $P(A) = 0.4$
 - $P(A/B') = 0.6$
 - $P(A'/B') = 0.4$
- Events A and B are independent. Given that $P(A) = 0.2$ and $P(B) = 0.15$. find
 - $P(A \cap B) = 0.03$
 - $P(A/B) = 0.2$ and $P(A \cup B) = 0.32$
- Events A and B are such that $P(A) = 0.2$, $P(A/B) = 0.4$ and $P(B) = 0.25$. Find
 - $P(A \cap B) = 0.1$
 - $P(B/A) = 0.5$
 - $P(A \cup B) = 0.35$
- Events A and B are such that $P(A) = \frac{1}{3}$, $P(B) = \frac{1}{4}$ and $P(A/B) = \frac{2}{5}$. Find
 - $P(A \cap B) = 0.1$
 - $P(B/A) = 0.3$

10. Events A and B are such that $P(A) = \frac{2}{3}$, $P(B) = \frac{1}{4}$ and $P(A/B) = \frac{2}{3}$. Find

(i) $P(A \cap B) = \frac{1}{6}$ (ii) $P(B/A) = \frac{1}{4}$

11. Events A and B are such that $P(B) = \frac{1}{3}$, $P(A) = \frac{1}{2}$ and $P(A \cap B') = \frac{1}{3}$. Find

(i) $P(A' \cup B') = \frac{5}{6}$ (ii) $P(B'/A') = \frac{2}{3}$

12. Events A and B are such that $P(A) = \frac{1}{2}$, $P(B) = \frac{3}{8}$ and $P(A/B) = \frac{7}{12}$. Find

(i) $P(A \cap B) = \frac{7}{32}$

(ii) $P(B/A') = \frac{3}{8}$

13. A and B are intersecting sets as shown in the Venn diagram below

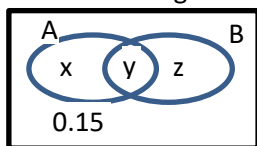

Given that $P(A) = 0.6$, $P(A'/B) = \frac{5}{7}$ and $P(A \cup B) = 0.85$. Find

(i) the values x, y and z ($x = 0.5$, $y = 0.1$ and $z = 0.25$)

(ii) $P(A/B) = \frac{2}{7}$ (iii) $P(A/B') = \frac{10}{13}$

14. Events A and B are independent with A twice likely to occur as B. If $P(A) = 0.5$, find

(i) $P(A \cup B) = \frac{5}{8}$ (ii) $P\left(\frac{A \cap B}{A}\right) = \frac{1}{8}$

15. Two events A and B are such that $P(A/B) = \frac{2}{5}$, $P(B) = \frac{1}{4}$ and $P(A) = \frac{1}{5}$. Find

(i) $P(A \cap B) = 0.1$ (ii) $P(A \cup B) = 0.35$

16. Two events a and B are such that $P(B/A) = \frac{1}{3}$, $P(B) = \frac{1}{8}$ and $P(A \cap B) = \frac{1}{10}$. Find

(i) $P(A) = 0.3$ (ii) $P(A \cup B) = 0.325$ (iii) $P(A/B) = 0.8$

17. Two events A and B are such that $P(A/B) = 0.1$, $P(A) = 0.7$ and $P(B) = 0.2$. Find

(i) $P(A \cup B) = 0.88$ (ii) $P(A \cap B') = 0.68$

Solutions to revision exercise D

1. Events X and Y are such that $P(X') = \frac{3}{5}$, $P(Y/X') = \frac{1}{3}$ and $P(Y'/X) = \frac{1}{4}$. Find

$P(Y) = \frac{1}{2}$

$P(Y/X') = \frac{P(Y \cap X')}{P(X')}$

$P(Y \cap X') = \frac{1}{3} \times \frac{3}{5} = \frac{1}{5}$

2. Events A and B are such that $P(A) = \frac{2}{5}$, $P(A/B) = \frac{1}{2}$, $P(B/A) = \frac{2}{3}$. Find

(i) $P(A \cap B)$

$P(B/A) = \frac{P(A \cap B)}{P(A)}$

$P(A \cap B) = \frac{2}{3} \times \frac{2}{5} = \frac{4}{15}$

(ii) $P(B)$

$$P(A/B) = \frac{P(A \cap B)}{P(B)}$$

$$P(B) = \frac{4}{15} \div \frac{1}{2} = \frac{4}{15} \times 2 = \frac{8}{15}$$

(iii) $P(A \cup B)$

$$P(A \cup B) = P(A) + P(B) - P(A \cap B) = \frac{2}{5} + \frac{8}{15} - \frac{4}{15} = \frac{10}{15} = \frac{2}{3}$$

3. Events A and B are such that $P(A) = \frac{1}{3}$, $P(B/A) = \frac{1}{4}$ and $P(B'/A') = \frac{4}{5}$. Find

(i) $P(B'/A) = \frac{3}{4}$

$P(B/A) =$

(ii) $P(A \cap B) = \frac{1}{12}$ (iii) $P(B) = \frac{13}{60}$ (iv) $P(A \cup B) = \frac{7}{15}$

4. Events A and B are such that $P(A) = \frac{1}{2}$, $P(B) = \frac{1}{3}$ and $P(A \cap B') = \frac{1}{3}$. Find

(i) $P(A' \cup B') = \frac{5}{6}$ (ii) $P(A'/B') = \frac{1}{2}$

5. Events A and B are such that $P(A \cap B) = \frac{1}{12}$, $P(B/A) = \frac{1}{3}$ and $P(B) = \frac{1}{6}$. Find

(i) $P(A) = \frac{1}{4}$ (ii) $P(A/B) = \frac{1}{2}$ (iii) $P(A/B') = \frac{1}{5}$

6. Events A and B are such that $P(A \cup B) = 0.8$, $P(A/B) = 0.2$ and $P(A' \cap B') = 0.4$. Find

(i) $P(A \cap B)$

(ii) $P(B) = 0.5$

(iii) $P(A) = 0.4$

(iv) $P(A/B') = 0.6$

(v) $P(A'/B') = 0.4$

7. Events A and B are independent. Given that $P(A) = 0.2$ and $P(B) = 0.15$. find

(i) $P(A \cap B) = P(A) \times P(B) = 0.2 \times 0.15 = 0.03$

(ii) $P(A/B) = \frac{P(A \cap B)}{P(B)} = \frac{0.03}{0.15} = 0.2$

(iii) $P(A \cup B) = P(A) + P(B) - P(A \cap B) = 0.2 + 0.15 - 0.03 = 0.32$

8. Events A and B are such that $P(A) = 0.2$, $P(A/B) = 0.4$ and $P(B) = 0.25$. Find

(i) $P(A \cap B)$

$$P(A/B) = \frac{P(A \cap B)}{P(B)}$$

$$P(A \cap B) = 0.4 \times 0.25 = 0.1$$

(ii) $P(B/A)$

$$P(B/A) = \frac{P(A \cap B)}{P(A)} = \frac{0.1}{0.2} = 0.5$$

(iii) $P(A \cup B)$

$$P(A \cup B) = P(A) + P(B) - P(A \cap B) = 0.2 + 0.25 - 0.1 = 0.35$$

9. Events A and B are such that $P(A) = \frac{1}{3}$, $P(B) = \frac{1}{4}$ and $P(A/B) = \frac{2}{5}$. Find

(i) $P(A \cap B)$

$$P(A/B) = \frac{P(A \cap B)}{P(B)}$$

$$P(A \cap B) = \frac{2}{5} \times \frac{1}{4} = \frac{1}{10}$$

(ii) $P(B/A) = 0.3$

$$P(B/A) = \frac{P(A \cap B)}{P(A)} = \frac{1}{10} \div \frac{1}{3} = \frac{3}{10}$$

10. Events A and B are such that $P(A) = \frac{2}{3}$, $P(B) = \frac{1}{4}$ and $P(A/B) = \frac{2}{3}$. Find

(i) $P(A \cap B)$

$$P(A/B) = \frac{P(A \cap B)}{P(B)}$$

$$P(A \cap B) = \frac{2}{3} \times \frac{1}{4} = \frac{1}{6}$$

(ii) $P(B/A)$

$$P(B/A) = \frac{P(A \cap B)}{P(A)} = \frac{1}{6} \div \frac{2}{3} = \frac{1}{6} \times \frac{3}{2} = \frac{1}{4}$$

11. Events A and B are such that $P(B) = \frac{1}{3}$, $P(A) = \frac{1}{2}$ and $P(A \cap B') = \frac{1}{3}$. Find

(i) $P(A' \cup B')$

$$P(A' \cup B') = 1 - P(A \cap B) = 1 - \frac{1}{2} \times \frac{1}{3} = \frac{5}{6}$$

(ii) $P(B'/A')$

$$P(B'/A') = \frac{P(A' \cap B')}{P(A')} = \frac{\frac{2}{3} \times \frac{1}{2}}{\frac{1}{2}} = \frac{2}{3}$$

12. Events A and B are such that $P(A) = \frac{1}{2}$, $P(B) = \frac{3}{8}$ and $P(A/B) = \frac{7}{12}$. Find

(i) $P(A \cap B)$

$$P(A/B) = \frac{P(A \cap B)}{P(B)}$$

$$P(A \cap B) = \frac{7}{12} \times \frac{3}{8} = \frac{7}{32}$$

(ii) $P(B/A')$

$$P(B/A') = \frac{P(B \cap A')}{P(A')} = \frac{\frac{3}{8} \times \frac{1}{2}}{\frac{1}{2}} = \frac{3}{8}$$

13. A and B are intersecting sets as shown in the Venn diagram below

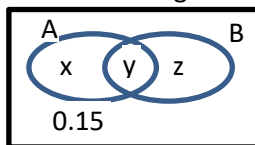

Given that $P(A) = 0.6$, $P(A'/B) = \frac{5}{7}$ and $P(A \cup B) = 0.85$. Find

(i) the values x , y and z

from the Venn diagram

$$x + y + z = 0.85 \dots\dots (i)$$

$$x + y = 0.6 \dots\dots\dots (ii)$$

subtracting eqn. (ii) from eqn. (i)

$$z = 0.85 - 0.6 = 0.25$$

$$P(A' \cap B) = \frac{P(A' \cap B)}{P(B)} = \frac{5}{7}$$

$$P(A' \cap B) = P(B) \text{ only} = 0.25$$

$$\Rightarrow 0.25 = \frac{5}{7} P(B)$$

$$P(B) = \frac{0.25 \times 7}{5} = 0.35$$

$$\text{But } P(B) = y + z = y + 0.25 = 0.35$$

$$y = 0.1$$

Substituting y in eqn.(i)

$$x + 0.1 = 0.6; x = 0.5$$

$$(ii) \quad P(A/B) = \frac{P(A \cap B)}{P(B)} = \frac{0.1}{0.35} = \frac{10}{35} = \frac{2}{7}$$

$$(iii) \quad P(A/B') = \frac{P(A \cap B')}{P(B')} = \frac{0.5}{0.65} = \frac{50}{65} = \frac{10}{13}$$

14. Events A and B are independent with A twice likely to occur as B. If $P(A) = 0.5$, find

$$(i) \quad P(A \cup B)$$

$$P(B) = 0.25$$

$$P(A \cup B) = P(A) + P(B) - P(A \cap B) = 0.5 + 0.25 - 0.5 \times 0.25 = 0.625$$

$$(ii) \quad P(A \cap B/A) = \frac{0.125 \times 0.5}{0.5} = 0.125$$

15. Two events A and B are such that $P(A/B) = \frac{2}{5}$, $P(B) = \frac{1}{4}$ and $P(A) = \frac{1}{5}$. Find

$$(i) \quad P(A \cap B)$$

$$P(A/B) = \frac{P(A \cap B)}{P(B)}$$

$$P(B) = 0.4 \times 0.25 = 0.1$$

$$(ii) \quad P(A \cup B)$$

$$P(A \cup B) = P(A) + P(B) - P(A \cap B) = 0.2 + 0.25 - 0.1 = 0.35$$

16. Two events a and B are such that $P(B/A) = \frac{1}{3}$, $P(B) = \frac{1}{8}$ and $P(A \cap B) = \frac{1}{10}$. Find

$$(i) \quad P(A) = 0.3$$

$$P(B/A) = \frac{P(A \cap B)}{P(A)}$$

$$P(A) = \frac{1}{10} \div \frac{1}{3} = \frac{3}{10} = 0.3$$

$$(ii) \quad P(A \cup B)$$

$$P(A \cup B) = P(A) + P(B) - P(A \cap B) = 0.3 + 0.125 - 0.1 = 0.325$$

$$(iii) \quad P(A/B)$$

$$P(A/B) = \frac{P(A \cap B)}{P(B)} = \frac{0.1}{0.125} = 0.8$$

17. Two events A and B are such that $P(A/B) = 0.1$, $P(A) = 0.7$ and $P(B) = 0.2$. Find

$$(i) \quad P(A \cup B) =$$

$$P(A/B) = \frac{P(A \cap B)}{P(B)}$$

$$P(A \cap B) = 0.1 \times 0.2 = 0.02$$

$$P(A \cup B) = P(A) + P(B) - P(A \cap B)$$

$$= 0.7 + 0.2 - 0.02 = 0.88$$

$$(ii) \quad P(A \cap B')$$

$$P(A \cap B') = P(A) - P(A \cap B) = 0.7 - 0.02 = 0.68$$

Combinations

The number of combinations of r objects from n unlike objects is ${}^n C_r$, where

$${}^n C_r = \frac{n!}{(n-r)!r!}$$

Example 25

Find the value of ${}^5 C_2 = \frac{5!}{(5-2)!2!} = \frac{5 \times 4 \times 3 \times 2 \times 1}{(3 \times 2 \times 1)(2 \times 1)} = 10$

Example 26

Find the number of ways of selecting a football team from 15 players

$${}^{15} C_{11} = 1365 \text{ ways}$$

Example 27

A committee of 4 men and 3 women is to be formed from 10 men and 8 women. In how many ways can the committee be formed?

$${}^{10} C_4 \times {}^8 C_3 = 210 \times 56 = 11760 \text{ ways}$$

Example 28

A group of 9 has to be selected from 8 girls it can consist of either 5 boys or 4 girls of 4 boys and 5 girls. Find how many different groups can be chosen

$${}^{10} C_5 \times {}^8 C_4 + {}^{10} C_4 \times {}^8 C_4 = 252 \times 70 + 210 \times 56 = 29400 \text{ ways}$$

Example 29

Three letters are chosen at random from the word CLOTHINGS. Determine the probability that two of the three letters chosen are consonants. (05markks)

Solution

Total number of letters in CLOTHINGS = 9 letters

Selection of 3 teachers from 9 letters ${}^9 C_3 = 84$

Possible selection

7 consonants	2 Vowels
2	1

$$\begin{aligned} \text{Number of selections} &= {}^7 C_2 \cdot {}^2 C_1 \\ &= 21 \times 2 \\ &= 42 \end{aligned}$$

$$\text{Probability} = \frac{42}{84} = \frac{1}{2}$$

Exercise E

1. A bag contains 5 Pepsi and 4 Mirinda bottle tops. Three bottle tops are picked at random from the bag one after the other without replacement. Find the probability that the bottle tops picked are of the same type.
2. In a group of 12 international referees, there are 3 from Africa, 4 from Asia and 5 from Europe. To officiate at a tournament 3 referees are chosen at random from the group, find the probability that:
 - (i) A referee is chosen from each continent
 - (ii) Exactly 2 referees are chosen from Asia
 - (iii) 3 referees are chosen from the same continent
3. Box P contains 4 red and 3 green sweets and box Q contains 7 red and 4 green sweets. A box is selected and 2 sweets are randomly picked from it, one at a time without replacement. If P is twice likely to be picked as Q, find the probability that both sweets are
 - (i) same colour
 - (ii) of different colour
 - (iii) from P given that they are different colours.
4. A bag contains 20 good and 4 bad oranges. If 5 oranges are selected at random without replacement. Find the probability that 4 are good and the other is bad = 0.456

Solutions to exercise E

1. A bag contains 5 Pepsi and 4 Mirinda bottle tops. Three bottle tops are picked at random from the bag one after the other without replacement. Find the probability that the bottle tops picked are of the same type.
Solution
 $n(S) = 3 \text{ tops from the } 9 = {}^9C_3 = 84 \text{ ways}$
 $n(E) = 3 \text{ Pepsi from } 5 + 3 \text{ Mirinda from } 4 = {}^5C_3 \times {}^4C_0 + {}^5C_0 \times {}^4C_3 = 10 + 4 = 14 \text{ ways}$
 $P(\text{same type}) = \frac{14}{84} = \frac{1}{6}$
2. In a group of 12 international referees, there are 3 from Africa, 4 from Asia and 5 from Europe. To officiate at a tournament 3 referees are chosen at random from the group, find the probability that:
 - (iv) A referee is chosen from each continent
 - (v) Exactly 2 referees are chosen from Asia
 - (vi) 3 referees are chosen from the same continent

Solution

$$(i) \quad n(S) = 3 \text{ referees from } 12 = 12C_3 = 220 \text{ ways}$$

$$n(E) = {}^3C_1 \times {}^4C_1 \times {}^5C_1 = 3 \times 4 \times 5 = 60 \text{ ways}$$

$$P(1 \text{ from each}) = \frac{60}{220} = \frac{3}{11}$$

$$(ii) \quad n(E) = 4C_2 \times 3C_1 \times 5C_0 + 4C_2 \times 3C_0 \times 5C_1 = 18 + 30 = 48 \text{ ways}$$
$$n(E) = {}^4C_2 \times {}^3C_1 \times {}^5C_0 + {}^4C_2 \times {}^3C_0 \times {}^5C_1$$

$$\begin{aligned}
&= 6 \times 3 \times 1 + 6 \times 1 \times 5 \\
&= 18 + 30 \\
&= 48 \text{ ways}
\end{aligned}$$

$$P(2 \text{ from Asia}) = \frac{48}{220} = \frac{12}{55}$$

$$\begin{aligned}
\text{(iii)} \quad n(E) &= {}^4C_3 \times {}^3C_0 \times {}^5C_0 + {}^4C_0 \times {}^3C_3 \times {}^5C_0 + {}^4C_0 \times {}^3C_0 \times {}^5C_2 \\
&= 4 \times 1 \times 1 + 1 \times 1 \times 1 + 1 \times 1 \times 10 \\
&= 4 + 1 + 10
\end{aligned}$$

$$P(3 \text{ from the same}) = \frac{15}{220} = \frac{3}{44}$$

3. Box P contains 4 red and 3 green sweets and box Q contains 7 red and 4 green sweets. A box is selected and 2 sweets are randomly picked from it, one at a time without replacement. If P is twice likely to be picked as Q, find the probability that both sweets are
- (iv) same colour
 - (v) of different colour
 - (vi) from P given that they are different colours.

Solution

$$\begin{aligned}
\text{(i)} \quad P(\text{both the same colour}) &= \frac{2}{3} \left[\frac{{}^4C_2 \times {}^3C_0}{7C_2} \right] + \frac{2}{3} \left[\frac{{}^4C_0 \times {}^3C_2}{7C_2} \right] + \frac{1}{3} \left[\frac{{}^7C_2 \times {}^4C_0}{11C_2} \right] + \frac{1}{3} \left[\frac{{}^7C_0 \times {}^4C_2}{11C_2} \right] \\
&= 0.4494
\end{aligned}$$

$$\text{(ii)} \quad P(\text{both different colour}) = \frac{2}{3} \left[\frac{{}^4C_1 \times {}^3C_1}{7C_2} \right] + \frac{1}{3} \left[\frac{{}^7C_1 \times {}^4C_1}{11C_2} \right] = 0.5506$$

$$\text{(iii)} \quad P(\text{from P/different colour}) = \frac{\frac{2[{}^4C_1 \times {}^3C_1]}{7C_2}}{0.5506} = 0.6919$$

4. A bag contains 20 good and 4 bad oranges. If 5 oranges are selected at random without replacement. Find the probability that 4 are good and the other is bad

$$P(X=4) = \frac{{}^{20}C_4 \cdot {}^4C_1}{{}^{24}C_5} = 0.456$$

Probability tree diagram

Example 30

A bag contains 5 black pens (B) and 4 red pens (R). Two pens are picked at random, one after the other without replacement. Find the probability that both pens are of the same color.

$$\text{Total pens } 5 + 4 = 9; \quad P(B) = \frac{5}{9}; \quad P(R) = \frac{4}{9};$$

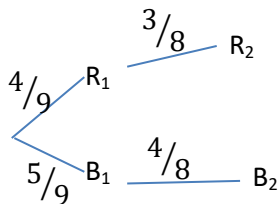

$$P(\text{both are same color}) = P(R_1 \cap R_2) + P(B_1 \cap B_2)$$

$$= \frac{4}{9} \cdot \frac{3}{8} + \frac{5}{9} \cdot \frac{4}{8} = \frac{20}{72} + \frac{20}{72} = \frac{40}{72} = \frac{5}{9}$$

$$= 0.4444$$

Example 31

A School student's council consists of 7 girls and 5 boys. Two students are selected at random from the council. Find the probability that;

Solution

Total number of students = 7 + 5 = 12

$$P(G) = \frac{7}{12} \text{ and } P(B) = \frac{5}{12}$$

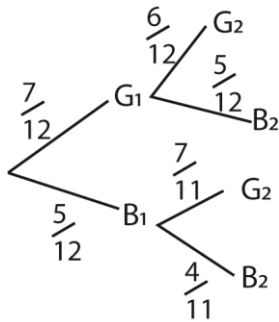

(a) Both are girls (02 marks)

$$P(\text{Both girls}) = P(G_1 \cap G_2)$$

$$= \frac{7}{12} \times \frac{6}{11} = \frac{7}{22}$$

Example 32

A factory makes cakes. When an inspector tests a random sample of cakes, the probability of any cake being contaminated is 0.025. Jane bought two of the cakes made from the factory. Find the probability

- (i) both are contaminated
- (ii) only one is contaminate

Solution

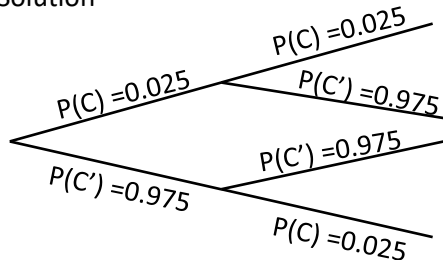

$$(i) P(\text{both contaminated}) = P(C \cap C) = 0.025 \times 0.025 = 0.000625$$

$$(ii) P(\text{one contaminated}) = P(C \cap C') + P(C' \cap C) = 0.025 \times 0.975 + 0.975 \times 0.025 = 0.04875$$

Example 33

A box contains 3 red balls and 4 blue balls. Two balls are randomly drawn one after the other without replacement. Find the probability that

- (i) 1st ball is blue
- (ii) 2nd ball is red
- (iii) 2nd ball is red given that the 1st was blue
- (iv) Both balls are of the same colour
- (v) Different colour

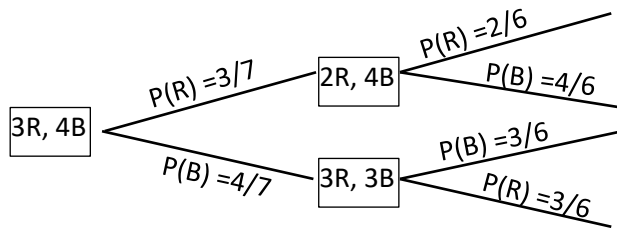

- (i) $P(1^{\text{st}} \text{ is blue}) = \frac{4}{7} \times \frac{3}{6} + \frac{4}{7} \times \frac{3}{6} = 0.5714$
- (ii) $P(2^{\text{nd}} \text{ is red}) = \frac{3}{7} \times \frac{2}{6} + \frac{4}{7} \times \frac{3}{6} = 0.4286$
- (iii) $P(2^{\text{nd}} \text{ is red given } 1^{\text{st}} \text{ is blue}) = \frac{3}{6} = 0.5$
- (iv) $P(\text{both same colour}) = \frac{3}{7} \times \frac{2}{6} + \frac{4}{7} \times \frac{3}{6} = 0.4286$
- (v) $P(\text{different colour}) = \frac{3}{7} \times \frac{4}{6} + \frac{4}{7} \times \frac{3}{6} = 0.5714$
Or $= 1 - 0.4286 = 0.5714$

Example 34

A bag contains 8 red pens and 3 green pens. Two pens are randomly picked one after the other, find the probability of drawing two pens of different colours, if the

- (i) first pen is not replaced
- (ii) first pen is replaced

Solution

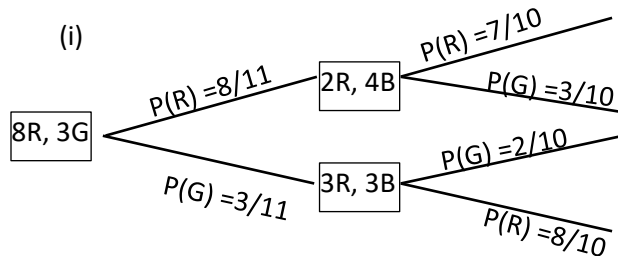

$$P(\text{different colour}) = \frac{8}{11} \times \frac{3}{10} + \frac{3}{11} \times \frac{8}{10} = \frac{24}{55}$$

- (ii)

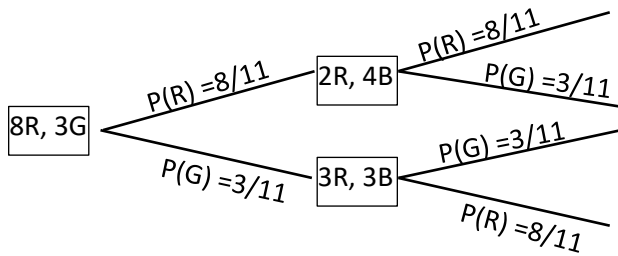

$$P(\text{different colour}) = \frac{8}{11} \times \frac{3}{11} + \frac{3}{11} \times \frac{8}{11} = \frac{48}{121}$$

Example 35

Bag A contains 8 red pens and 5 green pens. Bag B contains 6 red and 10 green pens. a pen is randomly picked from bag A and placed in bag B. A pen is then randomly picked from bag B, find the probability that it will be red

Solution

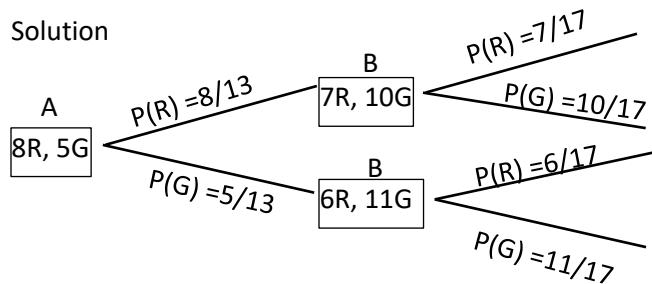

$$P(\text{Red pen}) = \frac{8}{13} \times \frac{7}{17} + \frac{5}{13} \times \frac{6}{17} = \frac{86}{221} = 0.3891$$

Example 36

Box A contains 6 red and 8 green sweets and box B contains 9 red and 7 green sweets. A box is randomly picked and 2 sweets are randomly picked from it, one at a time without replacement. If A is likely to be picked as B, find the probability that both sweets are

- (i) same colour
- (ii) from A given that are of same colour
- (iii) of different colours

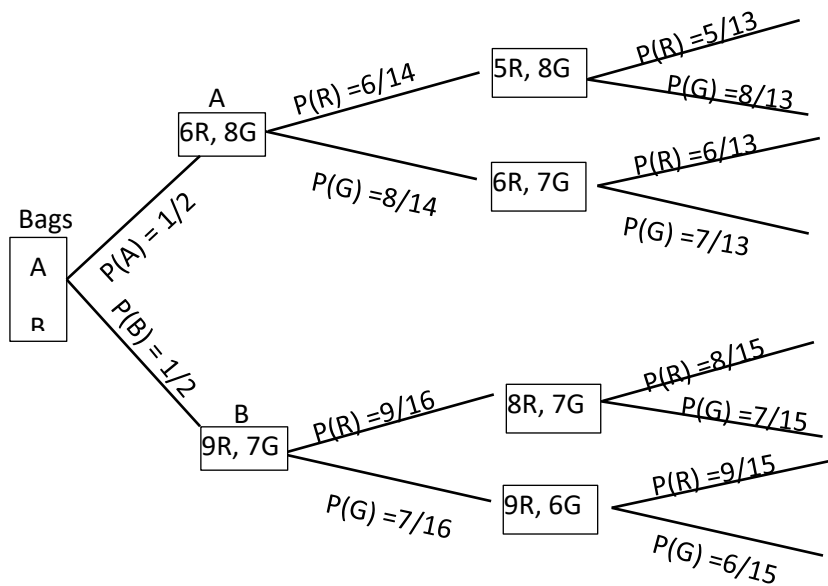

- (i) $P(\text{same colour}) = \frac{1}{2} \times \frac{6}{14} \times \frac{5}{13} + \frac{1}{2} \times \frac{8}{14} \times \frac{7}{13} + \frac{1}{2} \times \frac{9}{16} \times \frac{8}{15} + \frac{1}{2} \times \frac{7}{16} \times \frac{6}{15} = 0.4738$
- (ii) $P(\text{both different colour}) = 1 - 0.4738 = 0.5262$
- (iv) $P(\text{from A given that are of same colour}) = \frac{\frac{1}{2} \times \frac{6}{14} \times \frac{5}{13} + \frac{1}{2} \times \frac{8}{14} \times \frac{7}{13}}{0.4738} = 0.4987$

Exercise F

- A box contains 15 red and 5 black balls. Two balls are picked at random one after the other without replacement. find the probability that:
 - both are red = $\frac{21}{38}$
 - are different colour = $\frac{15}{38}$
 - both are black, given that the second ball is black
- A box contains 4 red balls and 6 black balls two balls are randomly drawn one after the other without replacement. Find the probability that
 - second ball is red given that the first ball is red = $\frac{1}{3}$
 - both balls are red = $\frac{2}{15}$
 - both balls of different colour = $\frac{8}{15}$
- A box contains 3 black balls and 5 white balls. Two balls are randomly drawn one after the other without replacement. find the probability
 - second ball is white = $\frac{5}{8}$
 - first ball is white given that the second ball is white = $\frac{4}{7}$
- A box contains 3 red sweets, 8 blue sweets and 7 green sweets. Three sweets are randomly drawn one after the other without replacement. Find that

- (i) all sweets are blue = $\frac{7}{102}$
- (ii) all sweets are red = $\frac{1}{816}$
- (iii) one of each colour = $\frac{7}{34}$
5. A box contains 7 black sweets and 3 white sweets. Three sweets are randomly drawn one after the other with replacement. Find the probability that:
- (i) all three sweets are black = 0.34
- (ii) a white, black and a white sweet in that order are chosen = 0.063
- (iii) two white and one black sweets are drawn = 0.189
- (iv) at least one black sweet drawn = 0.97
6. A coin is tossed four times, find the probability of obtaining less than two heads. = $\frac{5}{16}$
7. The probability that I am late for work is 0.05. Find the probability that on two consecutive mornings:
- (i) I am late for work twice = 0.0025
- (ii) I am late for work once = 0.095
8. A box A contains 3 red balls and 4 brown balls while box B contains 3 red balls and 2 brown balls. A box is drawn at random and one ball is randomly drawn from it. Find the probability that;
- (i) the ball is red = $\frac{18}{35}$
- (ii) the ball came from box A given that it is red = $\frac{5}{12}$
9. a bag contains 10 white and 6 red balls two balls are randomly drawn one after the other without replacement. Find the probability that the second ball drawn is
- (i) red given that the first one was white = 0.4
- (ii) white = 0.675
10. Box P contains 2 red balls and 2 blue balls while Box Q contains 2 red balls and 3 blue balls. A box is drawn at random and two balls are randomly drawn from it, one after the other without replacement. Find the probability that the balls are of different colour. = $\frac{19}{30}$.
11. A box contains 4 white balls and 1 black ball. A second box contains 1 white and 4 black balls. A ball is drawn at random from the first bag and put into the second bag, then a ball is taken from the second bag and put into the first bag. Find the probability that a white ball will be picked when a ball is selected from the first bag = $\frac{7}{10}$
12. (a) a box contains 7 red balls and 6 blue balls . Three balls are selected at random without replacement. find the probability that:
- (i) they are the same colour = 0.1923
- (ii) at most two are blue = 0.9301
- (b) Two boxes P and Q contain white and brown cards. P contains 6 white and 4 brown. Q contains 2 white and 3 brown. A box is selected at random and a card is selected at random. Find the probability that
- (i) a brown card is selected = 0.5
- (ii) Box Q is selected given that the card is white = 0.4

13. A box contains two types of balls, red and black. When a ball is picked from the box, the probability that it is red is $\frac{7}{12}$. Two balls are picked at random from the box without replacement. find the probability that
- The second ball is black = $\frac{5}{11}$
 - The first ball is red, given that the second one is black = $\frac{7}{11}$
14. A bag contains 30 white, 20 blue and 20 red balls. Three balls are selected at random without replacement. Find the Probability that the first ball is white and the ball is also white = 0.18
15. A box A contains 4 white and 2 re ball. Box B contains 3 white and 2 red balls. A box is selected at random and two balls are picked one after the other without replacement.
- Find the probability that the two balls picked are red. = 0.1333
 - Given that two white balls are picked, what is the probability that they are from box B = 0.3333

Solutions to exercise F

1. A box contains 15 red and 5 black balls. Two balls are picked at random one after the other without replacement. find the probability that:

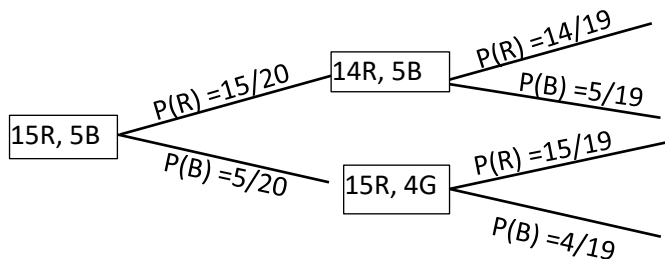

- (i) both are red

$$P(\text{both red}) = P(R \cap R) = \frac{15}{20} \times \frac{14}{19} = \frac{21}{38}$$

- (ii) are different colour

$$P(\text{different colour}) = P(R \cap B) + P(B \cap R) = \frac{15}{20} \times \frac{5}{19} + \frac{5}{20} \times \frac{15}{19} = \frac{15}{38}$$

- (iii) Both are black, given that the second ball is black = $\frac{20}{83}$

$$P(2^{\text{nd}} \text{ black}) = P(R \cap B) + P(B \cap B) = \frac{15}{20} \times \frac{5}{19} + \frac{5}{20} \times \frac{4}{19} = \frac{95}{380}$$

$$P(\text{both black}) = P(B \cap B) = \frac{5}{20} \times \frac{4}{19} = \frac{20}{380}$$

$$P(B/2^{\text{nd}} B) = \frac{20}{380} \div \frac{95}{380} = \frac{20}{95} = \frac{4}{19}$$

2. A box contains 4 red balls and 6 black balls two balls are randomly drawn one after the other without replacement. Find the probability that

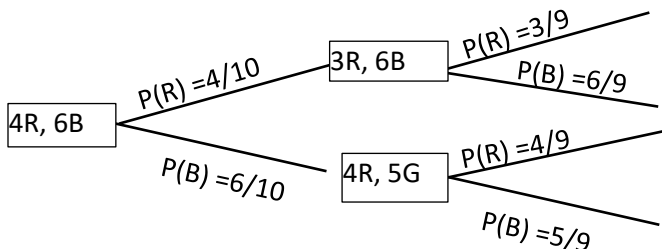

- (i) second ball is red given that the first ball is red

$$P(2^{\text{nd}} \text{ red} / 1^{\text{st}} \text{ red}) = \frac{3}{9} = \frac{1}{3}$$

- (ii) both balls are red

$$P(\text{both red}) = P(R \cap R) = \frac{4}{10} \times \frac{3}{9} = \frac{12}{90} = \frac{2}{15}$$

- (iii) both balls of different colour

$$P(\text{both different colour}) = P(R \cap B) + P(B \cap R) = \frac{4}{10} \times \frac{6}{9} + \frac{6}{10} \times \frac{4}{9} = \frac{8}{15}$$

3. A box contains 3 black balls and 5 white balls. Two balls are randomly drawn one after the other without replacement. find the probability

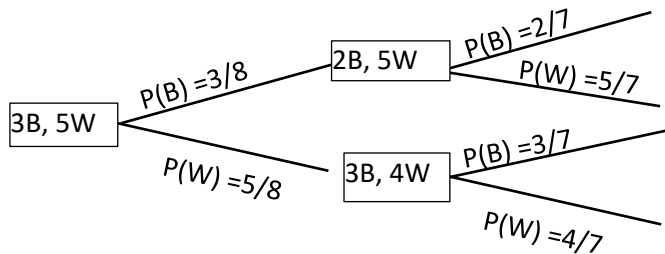

- (i) second ball is white

$$P(2^{\text{nd}} W) = P(B \cap W) + P(W \cap W) = \frac{3}{8} \times \frac{5}{7} + \frac{5}{8} \times \frac{4}{7} = \frac{5}{8}$$

- (ii) first ball is white given that the second ball is white = $\frac{4}{7}$

4. A box contains 3 red sweets, 8 blue sweets and 7 green sweets. Three sweets are randomly drawn one after the other without replacement. Find that

- (i) all sweets are blue

$$P(\text{all blue}) = \frac{8}{18} \times \frac{7}{17} \times \frac{6}{16} = \frac{7}{102}$$

- (ii) all sweets are red

$$P(\text{all red}) = \frac{3}{18} \times \frac{2}{17} \times \frac{1}{16} = \frac{1}{816}$$

- (iii) one of each colour

$$P(\text{each colour}) = P(R \cap B \cap G) + P(R \cap G \cap B) + P(B \cap R \cap G) + P(B \cap G \cap R) + P(G \cap B \cap R) + P(G \cap R \cap B)$$

$$= 6 \left(\frac{3}{18} \times \frac{8}{17} \times \frac{7}{16} \right) = \frac{7}{34}$$

5. A box contains 7 black sweets and 3 white sweets. Three sweets are randomly drawn one after the other with replacement. Find the probability that:

- (i) all three sweets are black

$$P(\text{all black}) = P(B \cap B \cap B) = 0.7 \times 0.7 \times 0.7 = 0.343$$

- (ii) a white, black and a white sweet in that order are chosen

$$= 0.3 \times 0.7 \times 0.3 = 0.063$$

- (iii) two white and one black sweets are drawn

$$P(2W, 1B) = P(W \cap W \cap B) + P(W \cap B \cap W) + P(B \cap W \cap W)$$

$$= 3(0.3 \times 0.3 \times 0.7) = 0.189$$

(iv) at least one black sweet drawn

$$\begin{aligned} P(\text{at least 1B}) &= [P(W \cap W \cap B) + P(W \cap B \cap W) + P(B \cap W \cap W)] + P(W \cap B \cap B) + \\ &P(B \cap B \cap W) + P(B \cap W \cap B) + P(B \cap B \cap B) \\ &= 0.189 + 3(0.3 \times 0.7 \times 0.7) + 0.7 \times 0.7 \times 0.7 \\ &= 0.973 \end{aligned}$$

6. A coin is tossed four times, find the probability of obtaining less than two heads.

$$\begin{aligned} P(\text{less than 2H}) &= P(H \cap T \cap T \cap T) + P(T \cap H \cap T \cap T) + P(T \cap T \cap H \cap T) + P(T \cap T \cap T \cap H) + P(T \cap T \cap T \cap T) \\ &= 5 \left(\frac{1}{2} \times \frac{1}{2} \times \frac{1}{2} \times \frac{1}{2} \right) = \frac{5}{16} \end{aligned}$$

7. The probability that I am late for work is 0.05. Find the probability that on two consecutive mornings:

(i) I am late for work twice
 $= P(L \cap L) = 0.05 \times 0.05 = 0.0025$

(ii) I am late for work once
 $= P(L \cap L') + P(L' \cap L) = 2(0.05 \times 0.95) = 0.095$

8. A box A contains 3 red balls and 4 brown balls while box B contains 3 red balls and 2 brown balls. A box is drawn at random and one ball is randomly drawn from it. Find the probability that;

(i) the ball is red
 $P(R) = P(A \cap R) + P(B \cap R) = \frac{1}{2} \times \frac{3}{7} + \frac{1}{2} \times \frac{3}{5} = \frac{3}{14} + \frac{3}{10} = \frac{18}{35}$

(ii) the ball came from box A given that it is red
 $P(A/R) = \frac{P(A \cap R)}{P(R)} = \frac{3}{14} \times \frac{35}{18} = \frac{5}{12}$

9. A bag contains 10 white and 6 red balls two balls are randomly drawn one after the other without replacement. Find the probability that the second ball drawn is

(i) red given that the first one was white
 $= \frac{6}{15} = 0.4$

(ii) white
 $P(2^{\text{nd}} W) = P(W \cap W) + P(R \cap W) = \frac{10}{16} \times \frac{9}{15} + \frac{6}{16} \times \frac{10}{15} = 0.675$

10. Box P contains 2 red balls and 2 blue balls while Box Q contains 2 red balls and 3 blue balls. A box is drawn at random and two balls are randomly drawn from it, one after the other without replacement. Find the probability that the balls are of different colour. $= \frac{19}{30}$.

$$\begin{aligned} P(\text{different colour}) &= P(P \cap R \cap B) + P(P \cap B \cap R) + P(Q \cap R \cap B) + P(Q \cap B \cap R) \\ &= \frac{1}{2} \times \frac{2}{4} \times \frac{2}{3} + \frac{1}{2} \times \frac{2}{3} \times \frac{2}{4} + \frac{1}{2} \times \frac{2}{5} \times \frac{3}{4} + \frac{1}{2} \times \frac{3}{5} \times \frac{2}{4} \\ &= \frac{1}{6} + \frac{1}{6} + \frac{3}{20} + \frac{3}{20} = \frac{10+10+9+9}{60} = \frac{19}{30} \end{aligned}$$

11. A box contains 4 white balls and 1 black ball. A second box contains 1 white and 4 black balls. A ball is drawn at random from the first bag and put into the second bag, then a ball is taken from the second bag and put into the first bag. Find the probability that a white ball will be picked when a ball is selected from the first bag $= \frac{7}{10}$

Let A = 1st bag and B = 2nd bag

W_1 = a white ball drawn from A for the first time

B_1 = a black ball drawn from A for the first time

W_2 = a white ball drawn from A for the second time

B_2 = a black ball draw from A for the second time
 W_3 = a white ball drawn from A for the second time
 B_3 = a black ball draw from A for the second time

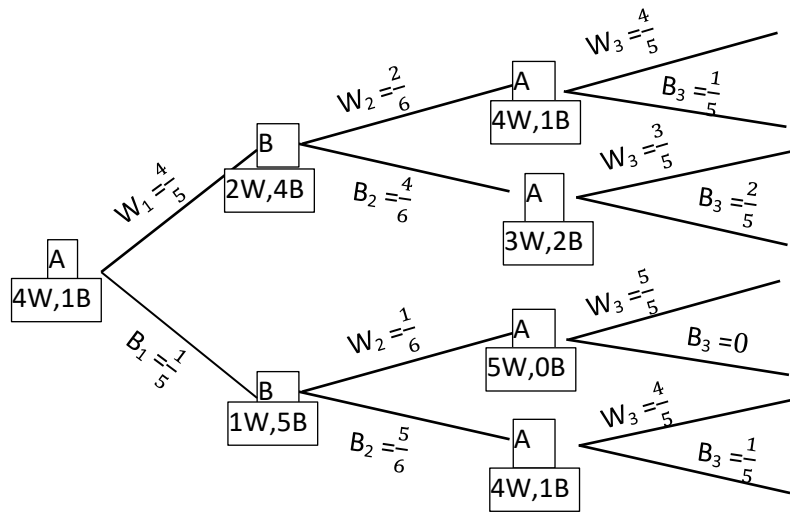

Let W = event that a white ball is then selected from Bag A

$$P(W) = P(W_1 \cap W_2 \cap W_3) + P(W_1 \cap B_2 \cap W_3) + P(B_1 \cap W_2 \cap W_3) + P(B_1 \cap B_2 \cap W_3)$$

$$= \frac{4}{5} \times \frac{2}{6} \times \frac{4}{5} + \frac{4}{5} \times \frac{4}{6} \times \frac{3}{5} + \frac{1}{5} \times \frac{1}{6} \times \frac{5}{5} + \frac{1}{5} \times \frac{5}{6} \times \frac{4}{5} = \frac{32}{150} + \frac{48}{150} + \frac{5}{150} + \frac{20}{150} = \frac{105}{150} = \frac{7}{10}$$

12. (a) A box contains 7 red balls and 6 blue balls. Three balls are selected at random without replacement. find the probability that:

- (i) they are the same colour

$$P(\text{same colour}) = P(R \cap R \cap R) + P(B \cap B \cap B) = \frac{7}{13} \times \frac{6}{12} \times \frac{5}{11} + \frac{6}{13} \times \frac{5}{12} \times \frac{4}{11} = 0.1923$$

- (ii) at most two are blue

$$\begin{aligned}
 P(\text{at most 2B}) &= P(R \cap R \cap R) + P(R \cap R \cap B) + P(B \cap R \cap R) + P(R \cap B \cap R) + P(R \cap B \cap B) + \\
 &\quad P(B \cap B \cap R) + P(B \cap R \cap B) \\
 &= 1 - P(B \cap B \cap B) = 1 - \frac{6}{13} \times \frac{5}{12} \times \frac{4}{11} = 0.9301
 \end{aligned}$$

- (b) Two boxes P and Q contain white and brown cards. P contains 6 white and 4 brown. Q contains 2 white and 3 brown. A box is selected at random and a card is selected at random. Find the probability that

- (i) a brown card is selected

$$P(B) = P(P \cap B) + P(Q \cap B) = \frac{1}{2} \times \frac{4}{10} + \frac{1}{2} \times \frac{3}{5} = 0.5$$

- (ii) Box Q is selected given that the card is white

$$P(W) = P(P \cap W) + P(Q \cap W) = \frac{1}{2} \times \frac{6}{10} + \frac{1}{2} \times \frac{2}{5} = 0.5$$

$$P(Q/W) = \frac{P(Q \cap W)}{P(W)} = \frac{0.2}{0.5} = 0.4$$

13. A box contains two types of balls, red and black. When a ball is picked from the box, the probability that it is red is $\frac{7}{12}$. Two balls are picked at random from the box without replacement.

find the probability that

(i) The second ball is black

$$P(R) = \frac{7}{12}, P(B) = \frac{5}{12}$$

$$P(B) = P(R \cap B) + P(B \cap B) = \frac{7}{12} \times \frac{5}{11} + \frac{5}{12} \times \frac{4}{11} = \frac{5}{11}$$

(ii) The first ball is red given that the second one is black

$$P(1^{\text{st}} B/B) = \frac{P(R \cap B)}{P(B)} = \frac{35}{121} \div \frac{5}{11} = \frac{35}{121} \times \frac{11}{5} = \frac{7}{11}$$

14. A bag contains 30 white, 20 blue and 20 red balls. Three balls are selected at random without replacement. Find the Probability that the first ball is white and the third ball is also white

$$P = P(W \cap B \cap W) + P(W \cap R \cap W) + P(W \cap W \cap W) = \frac{30}{70} \times \frac{20}{69} \times \frac{29}{68} + \frac{30}{70} \times \frac{20}{69} \times \frac{29}{68} + \frac{30}{70} \times \frac{29}{69} \times \frac{28}{68} = 0.18$$

15. A box A contains 4 white and 2 red balls. Box B contains 3 white and 3 red balls. A box is selected at random and two balls are picked one after the other without replacement.

(i) Find the probability that the two balls picked are red.

$$P(R) = P(A \cap R_1 \cap R_2) + P(B \cap R_1 \cap R_2) = \frac{1}{2} \times \frac{2}{6} \times \frac{1}{5} + \frac{1}{2} \times \frac{3}{6} \times \frac{2}{5} = \frac{8}{60} = 0.1333$$

(ii) Given that two white balls are picked, what is the probability that they are from box B

$$P(W) = P(A \cap W_1 \cap W_2) + P(B \cap W_1 \cap W_2) = \frac{1}{2} \times \frac{4}{6} \times \frac{3}{5} + \frac{1}{2} \times \frac{3}{6} \times \frac{2}{5} = \frac{18}{60}$$

$$P(B/W) = \frac{P(B \cap W_1 \cap W_2)}{P(W)} = \frac{6}{60} \div \frac{18}{60} = \frac{6}{18} = \frac{1}{3} = 0.3333$$

Conditional probability using a tree diagram/ Baye's Rule

Example 37

During planting season a farmer treats $\frac{2}{3}$ of his seeds and $\frac{1}{3}$ of the seed are left untreated. The seeds which are treated have a probability of germinating of 0.8 while the untreated seeds have a probability of germinating of 0.5, find the probability that a seed selected at random

(i) will germinate

(ii) had been treated, given that it had germinated.

Solution

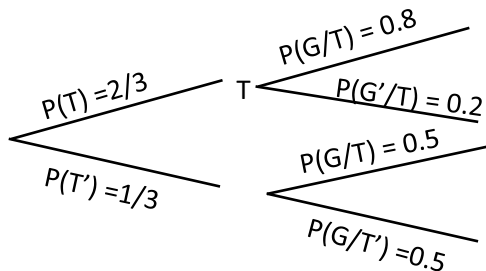

$$P(G) = P(T \cap G) + P(T' \cap G) = \frac{2}{3} \times 0.8 + \frac{1}{3} \times 0.5 = 0.7$$

$$P(T/G) = \frac{P(T \cap G)}{P(G)} = \frac{\frac{2}{3} \times 0.8}{0.7} = 0.762$$

Example 38

The probability that a golfer hits the ball on the green if it is windy as he strikes the ball is 0.4 and the corresponding probability if it is not windy as he strikes the ball is 0.7. The probability that the wind blow as he strikes the ball is $\frac{3}{10}$. Find the probability that

- (i) He hits the ball on the green
- (ii) It was not windy, given that he does not hit the ball on the green

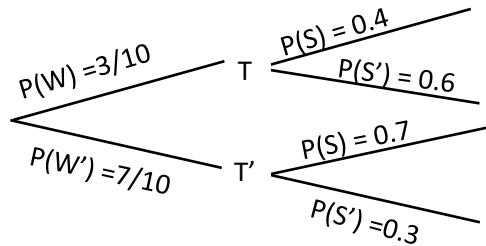

- (i) $P(S) = P(W \cap S) + P(W' \cap S) = 0.3 \times 0.4 + 0.7 \times 0.7 = 0.61$
- (ii) $P(W'/S') = \frac{P(W' \cap S')}{P(S')} = \frac{\frac{7}{10} \times 0.3}{(1-0.61)} = 0.5385$

Example 39

When students were to go for a geography tour, the school hired three different types of vehicles, buses, coaster and taxis. Of the hiring's 40% were buses, 50% were coasters and 10% were taxis. For bus hired 9% arrive late, the corresponding percentages for a coaster and a taxi being 6% and 20% respectively. Find the probability that the next vehicle hired

- (i) will be a bus and will not arrive late
- (ii) will arrive late
- (iii) will be a coaster given that it will arrive late

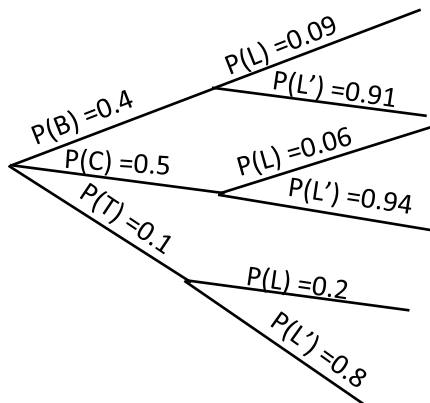

- (i) $P(B \cap L') = 0.4 \times 0.91 = 0.364$
- (ii) $P(L) = P(B \cap L) + P(C \cap L) + P(T \cap L)$
 $= 0.4 \times 0.09 + 0.5 \times 0.06 + 0.1 \times 0.2$
 $= 0.086$
- (iii) $P(C/L) = \frac{P(C \cap L)}{P(L)} = \frac{(0.5 \times 0.06)}{0.086} = 0.3488$

Revision exercise G

- 55% of the teachers at a certain school are male. 30% of the male teachers are science teachers and 5% of female teachers teach sciences. If a teacher is selected at random, what is the probability that
 - Teaches sciences = 0.1875
 - She is a female given that she does not teach sciences. = 0.5262
- The probability that a golfer hits the ball on the green if it is windy as he strikes the ball is 0.4 and the corresponding probability if it is not windy as he strikes the ball is 0.7. The probability that the wind blows as he strikes the ball is $\frac{3}{10}$. Find the probability that:
 - he hits the ball on the green = 0.61
 - it was not windy, given that he does not hit the ball on the green = 0.5385
- In a restaurant, 40% of the customer's order for chicken. If a customer orders, the probability that he will take juice is 0.6. If he does not order chicken, the probability that he will take juice is 0.3. Find the probability a customer picked at random will order
 - Chicken and juice = 0.24
 - Juice = 0.42
- In a factory, there are two different machines A and B. Items are produced from A and B with respective probabilities of 0.2 and 0.8. It was established that 5% and 8% produced by A and B respectively are defective. If one item is selected randomly, find the probability that
 - it is defective = 0.074
 - it is produced by A given that it is defective = 0.1351
- Data from electoral commission showed that in the previous election, of all the Kampala parliamentary contestants, 70% were N.R.M, 20% were F.D.C and 10% were independents. 5% N.R.M contestants won elections, 95% of F.D.C contestants won elections and 25% of the independent contestants won elections. If a contestant is chosen at random, find the probability that the person
 - won election = 0.25
 - an F. D.C won elections = 0.19
- A student travels to school by route A or route B. The probability that she uses route A is 0.25. The probability that she is late to school if she uses route A is $\frac{2}{3}$ and the corresponding probability if she uses route B is $\frac{1}{3}$.
 - Find the probability that she will be late to school = $\frac{5}{12}$.
 - Given that she is late, what is the probability that she used route B = $\frac{3}{5}$.
- A student is to travel to school for an interview. The probability that he will be in time for the interview when he travels taxi and boda respectively are 0.1 and 0.2. The probability that he will travel by taxi and boda are 0.6 and 0.4 respectively.
 - find the probability that he will be on time = 0.14
 - given that he is not on time, what is the probability that he travelled by boda = 0.372

8. Of the group of students studying A-level in a school, 56% are boys and 44% are girls. The probability that a boy of this group is studying chemistry is $\frac{1}{5}$ and the probability that a girl of this group is studying chemistry is $\frac{1}{11}$:
- Find the probability that a student selected at random from this group is a girl studying chemistry. = $\frac{1}{25}$
 - Find the probability that a student selected at random from this group is not studying chemistry. = $\frac{106}{125}$
 - Find the probability that a chemistry student selected at random from this group is male = $\frac{14}{19}$
9. When a school wants to buy chalk, the school phones three suppliers A, B or C of the phone calls to them. 30% are to A, 10% to B and 60% to C. the percentage of occasions when the supplies deliver chalk after a phone call to them are 20% for A, 6% for B and 9% for C.
- Find the probability that the supplier phoned will not deliver chalk on the day if phoning. = 0.88
 - Given that the school phones a supplier and the supplier can deliver chalk that, find the probability that the school phoned supplier B. = 0.05
10. In Kampala city, 30% of the people are F.D.C, 50% are N.R.M and 20% are independent. Records show that in previous elections, 65% of the F.D.C voted, 85% of the N.R.M voted and 50% of the independent voted. A person is randomly selected from the city.
- Find the probability that the person voted = 0.72
 - Given that the person didn't vote, determine the probability that is an F.D.C = 0.375
11. A shop stocks two brands of toothpaste, Colgate toothpaste and Fresh up toothpaste, and two sizes, large and small. Of the stock 70% is Colgate and 30% is Fresh up. Of the Colgate, 30% are small size and of Fresh up 40% are small size. Find the probability that;
- A toothpaste chosen at random from the stalk will be of small size = 0.33
 - Small toothpaste chosen at random from the stalk will be of Colgate. = $\frac{7}{11}$
12. At a bus park, 60% of the buses are of Teso coaches, 25% are Kakise buses and the rest are Y.Y buses. Of the Teso coaches 50% have TVs, while for the Kakise and Y.Y buses only 55 and 15 have TVs respectively. If a bus is selected at random from the park, determine the probability that
- Has a TV = 0.314
 - Kakise bus is selected that it has TV = 0.0398
13. On a certain day, fresh fish from lakes, Kyoga, Victoria, Albert and George were supplied to a market in ratio 30%, 40%, 20% and 10% respectively. Each lake had an estimated ratios of poisoned fish of 2%, 3%, 3% and 1% respectively. If a health inspector picked a fish at random
- What is the probability that the fish was poisoned = 0.025
 - Given that the fish was poisoned, what is the probability that it was from L. albert. = 0.24
14. The chance that a person picked from a Kampala street is employed is 30 in every 48. The probability that a person is a university graduate is employed is 0.6. Find
- the probability that the person picked at random from the street is a university graduate and is employed = 0.375
 - number of people that are not university graduates and are employed from a group of 120 people. = 30

15. A mobile phone dealer imports Nokia and Motorola phones. In a given consignment, 55% were Nokia and 45% were Motorola phones. The probability that a Nokia phone is defective is 4%. The probability that a Motorola phone is defective is 6%. A phone is picked at random from the consignment. Determine that it is

- (i) defective = 0.049
- (ii) a Motorola given that it is defective = 0.551

Solutions to revision exercise G

1. 55% of the teachers at a certain school are male. 30% of the male teachers are science teachers and 5% of female teachers teach sciences. If a teacher is selected at random, what is the probability that

$$P(M) = 0.55, P(F) = 0.45, P(S/M) = 0.3, P(S/F) = 0.05, P(S'/F) = 0.95$$

(i) Teaches sciences

$$P(S) = P(M \cap S) + P(F \cap S) = 0.55 \times 0.3 + 0.45 \times 0.05 = 0.1875$$

(ii) She is a female given that she does not teach sciences.

$$P(S') = 1 - P(S) = 1 - 0.1875 = 0.8125$$

$$P(F/S') = \frac{P(F \cap S')}{P(S')} = \frac{0.45 \times 0.95}{0.8125} = 0.5262$$

2. The probability that a golfer hits the ball on the green if it is windy as he strikes the ball is 0.4 and the corresponding probability if it is not windy as he strikes the ball is 0.7. The probability that the wind blows as he strikes the ball is $\frac{3}{10}$. Find the probability that:

Summary

$$P(S/W) = 0.4, P(S/W') = 0.7, P(W) = 0.3, P(W') = 0.7$$

(i) he hits the ball on the green

$$P(S) = P(S \cap W) + P(S \cap W') = 0.4 \times 0.3 + 0.7 \times 0.7 = 0.61$$

(ii) it was not windy, given that he does not hit the ball on the green

$$P(S') = 1 - 0.61 = 0.39$$

$$P(W'/S') = \frac{P(W' \cap S')}{P(S')} = \frac{0.7 \times 0.3}{0.39} = 0.5385$$

3. In a restaurant, 40% of the customer's order for chicken. If a customer orders, the probability that he will take juice is 0.6. If he does not order chicken, the probability that he will take juice is 0.3. Find the probability a customer picked at random will order

$$P(C) = 0.4, P(C') = 0.6, P(J/C) = 0.6, P(J/C') = 0.3$$

(i) Chicken and juice

$$P(C \cap J) = 0.4 \times 0.6 = 0.24$$

(ii) Juice

$$P(J) = P(C \cap J) + P(C' \cap J) = 0.24 + 0.6 \times 0.3 = 0.42$$

4. In a factory, there are two different machines A and B. Items are produced from A and B with respective probabilities of 0.2 and 0.8. It was established that 5% and 8% produced by A and B respectively are defective. If one item is selected randomly, find the probability that

Summary

$$P(A) = 0.2, P(B) = 0.8, P(D/A) = 0.05, P(D/B) = 0.08$$

(i) it is defective

$$P(D) = P(A \cap D) + P(B \cap D) = 0.2 \times 0.05 + 0.8 \times 0.08 = 0.074$$

(ii) it is produced by A given that t is defective

$$P(A/D) = \frac{P(A \cap D)}{P(D)} = \frac{0.2 \times 0.05}{0.074} = 0.1351$$

5. Data from electoral commission showed that in the previous election, of all the Kampala parliamentary contestants, 70% were N.R.M, 20% were F.D.C and 10% were independents. 5% N.R.M contestants won elections, 95% of F.D.C contestants won elections and 25% of the independent contestants won elections. If a contestant is chosen at random, find the probability that the person

Summary

$$P(N) = 0.7, P(F) = 0.2, P(I) = 0.1, P(W/N) = 0.05, P(W/F) = 0.95, P(W/I) = 0.25$$

(i) won election

$$P(W) = P(N \cap W) + P(F \cap W) + P(I \cap W) = 0.7 \times 0.05 + 0.2 \times 0.95 + 0.1 \times 0.25 = 0.25$$

(ii) an F. D.C won elections = $0.2 \times 0.95 = 0.19$

6. A student travels to school by route A or route B. The probability that she uses route A is 0.25. The probability that she is late to school if she uses route A is $\frac{2}{3}$ and the corresponding probability if she uses route B is $\frac{1}{3}$.

$$P(A) = 0.25, P(B) = 0.75, P(L/A) = \frac{2}{3}, P(L/B) = \frac{1}{3}$$

(i) Find the probability that she will be late to school.

$$P(L) = P(A \cap L) + P(B \cap L) = 0.25 \times \frac{2}{3} + 0.75 \times \frac{1}{3} = 0.417$$

(ii) Given that she is late, what is the probability that she used route B

$$P(L/B) = \frac{P(B \cap L)}{P(L)} = \frac{0.25}{0.417} = 0.6$$

7. A student is to travel to school for an interview. The probability that he will be on time for the interview when he travels taxi and boda respectively are 0.1 and 0.2. The probability that he will travel by taxi and boda are 0.6 and 0.4 respectively.

Summary

$$P(T) = 0.6, P(B) = 0.4, P(t/T) = 0.1, P(t'/T) = 0.9, P(t/B) = 0.2, P(t'/B) = 0.8$$

(i) find the probability that he will be on time

$$P(\text{on time}) = P(t) = P(T \cap t) + P(B \cap t) = 0.6 \times 0.1 + 0.4 \times 0.2 = 0.14$$

(ii) given that he is not on time, what is the probability that he travelled by boda

$$\text{Probability that he is not on time} = 1 - P(t) = 1 - 0.14 = 0.86$$

$$P(B/t') = \frac{P(t' \cap B)}{P(t')} = \frac{0.4 \times 0.8}{0.86} = 0.372$$

8. Of the group of students studying A-level in a school, 56% are boys and 44% are girls. The probability that a boy of this group is studying chemistry is $\frac{1}{5}$ and the probability that a girl of this group is studying chemistry is $\frac{1}{11}$:

Summary

$$P(B) = 0.56, P(G) = 0.44, P(C/B) = 0.2, P(C/G) = \frac{1}{11}$$

- (i) Find the probability that a student selected at random from this group is a girl studying chemistry.
 $P(G \cap C) = P(G) \times P(G/C) = 0.44 \times \frac{1}{11} = 0.04$
- (ii) Find the probability that a student selected at random from this group is not studying chemistry.
 $P(C') = 1 - P(C) = 1 - 0.152 = 0.848$
- (iii) Find the probability that a chemistry student selected at random from this group is male = $\frac{14}{19}$
 $P(B/C) = \frac{P(B \cap C)}{P(C)} = \frac{0.56 \times 0.2}{0.152} = 0.73684$

9. When a school wants to buy chalk, the school phones three suppliers A, B or C of the phone calls to them. 30% are to A, 10% to B and 60% to C. the percentage of occasions when the supplies deliver chalk after a phone call to them are 20% for A, 6% for B and 9% for C.

Summary

$P(A) = 0.3, P(B) = 0.1, P(C) = 0.6, P(D/A) = 0.2, P(D'/A) = 0.8, P(D/B) = 0.06, P(D'/B) = 0.94,$
 $P(D/C) = 0.09, P(D'/C) = 0.91$

- (i) Find the probability that the supplier phoned will not deliver chalk on the day if phoning.
 $P(D') = P(D' \cap A) + P(D' \cap B) + P(D' \cap C) = 0.3 \times 0.8 + 0.1 \times 0.94 + 0.6 \times 0.91 = 0.88$
- (ii) Given that the school phones a supplier and the supplier can deliver chalk that, find the probability that the school phoned supplier B.
 $P(D) = P(D \cap A) + P(D \cap B) + P(D \cap C) = 0.3 \times 0.2 + 0.1 \times 0.06 + 0.6 \times 0.09 = 0.12$
 Or $= 1 - P(D') = 1 - 0.88 = 0.12$
 $P(B/D) = \frac{P(D \cap B)}{P(D)} = \frac{0.1 \times 0.06}{0.12} = 0.05$

10. In Kampala city, 30% of the people are F.D.C, 50% are N.R.M and 20% are independent. Records show that in previous elections, 65% of the F.D.C voted, 85% of the N.R.M voted and 50% of the independent voted. A person is randomly selected from the city.

Summary

$P(F) = 0.3, P(N) = 0.5, P(I) = 0.2, P(V/F) = 0.65, P(V/N) = 0.85, P(V/I) = 0.5$

- (i) Find the probability that the person voted
 $P(V) = P(V \cap F) + P(V \cap N) + P(V \cap I) = 0.3 \times 0.65 + 0.5 \times 0.85 + 0.2 \times 0.5 = 0.72$
- (ii) Given that the person didn't vote, determine the probability that is an F.D.C
 $P(V') = P(V' \cap F) + P(V' \cap N) + P(V' \cap I) = 0.3 \times 0.35 + 0.5 \times 0.15 + 0.2 \times 0.5 = 0.28$
 $P(V'/F) = \frac{P(V' \cap F)}{P(V')} = \frac{0.3 \times 0.35}{0.28} = 0.375$

11. A shop stocks two brands of toothpaste, Colgate toothpaste and Fresh up toothpaste, and two sizes, large and small. Of the stock 70% is Colgate and 30% is Fresh up. Of the Colgate, 30% are small size and of Fresh up 40% are small size. Find the probability that;

Summary

$P(C) = 0.7 \quad P(F) = 0.3, P(s/C) = 0.3, P(s/F) = 0.4$

(i) A toothpaste chosen at random from the stalk will be of small size

$$P(s) = P(C \cap s) + P(F \cap s) = 0.7 \times 0.3 + 0.3 \times 0.4 = 0.33$$

(ii) Small toothpaste chosen at random from the stalk will be of Colgate.

$$P(C/s) = \frac{P(C \cap s)}{P(s)} = \frac{0.21}{0.33} = \frac{7}{11}$$

12. At a bus park, 60% of the buses are of Teso coaches, 25% are Kakise buses and the rest are Y.Y buses. Of the Teso coaches 50% have TVs, while for the Kakise and Y.Y buses only 55 and 15 have TVs respectively. If a bus is selected at random from the park, determine the probability that:

Let T, K, Y stand for Teso, Kakise and Y, Y buses

$$P(T) = 0.6 \quad P(K) = 0.25 \quad \text{and} \quad P(Y) = 0.15$$

$$P(R/T) = 0.5, \quad P(R/K) = 0.05, \quad P(R/Y) = 0.01$$

(i) Has a TV = 0.0315

$$\begin{aligned} P(t) &= P(T \cap t) + P(K \cap t) + P(Y \cap t) \\ &= P(R/T) \cdot P(T) + P(R/K) \cdot P(K) + P(R/Y) \cdot P(Y) \\ &= 0.6 \times 0.5 + 0.25 \times 0.05 + 0.15 \times 0.01 \\ &= 0.314 \end{aligned}$$

(ii) Kakise bus is selected that it has TV

$$P(K/T) = \frac{P(K \cap T)}{P(T)} = \frac{0.0125}{0.314} = 0.0398$$

13. Height of female students at particular college are normally distributed with

14. On a certain day, fresh fish from lakes, Kyoga, Victoria, Albert and George were supplied to a market in ratio 30%, 40%, 20% and 10% respectively. Each lake had an estimated ratios of poisoned fish of 2%, 3%, 3% and 1% respectively. If a health inspector picked a fish at random

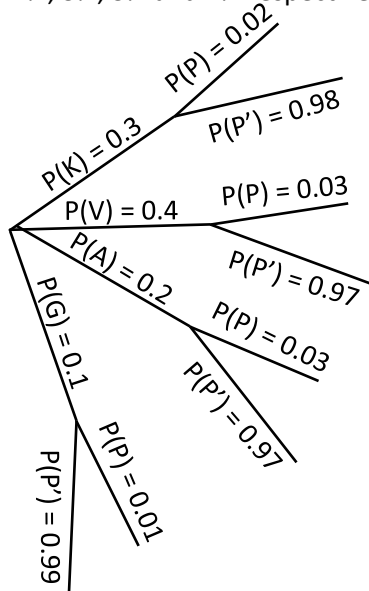

- (i) What is the probability that the fish was poisoned

$$\begin{aligned}
 P(\text{poisoned}) &= P(K \cap P) + P(V \cap P) + P(A \cap P) + P(G \cap P) \\
 &= 0.3 \times 0.02 + 0.4 \times 0.03 + 0.2 \times 0.03 + 0.1 \times 0.01 \\
 &= 0.025
 \end{aligned}$$

- (ii) Given that the fish was poisoned, what is the probability that it was from L. albert. = 0.24

$$P(A/P) = \frac{P(A \cap P)}{P(P)} = \frac{0.006}{0.025} = 0.24$$

15. The chance that a person picked from a Kampala street is employed is 30 in every 48. The probability that a person is a university graduate is employed is 0.6. Find

$$P(E) = \frac{30}{48} = 0.625 \text{ and } P(G/E) = 0.6$$

- (i) the probability that the person picked at random from the street is a university graduate and is employed

$$\begin{aligned}
 P(G/E) &= \frac{P(G \cap E)}{P(E)} \\
 P(G \cap E) &= 0.625 \times 0.6 = 0.375
 \end{aligned}$$

- (ii) number of people that are not university graduates and are employed from a group of 120 people. = 30

$$\begin{aligned}
 &\text{From set theory} \\
 P(E) &= P(G \cap E) + P(G' \cap E) \\
 P(G' \cap E) &= 0.625 - 0.375 = 0.25 \\
 \text{The number} &= 0.25 \times 120 = 30
 \end{aligned}$$

16. A mobile phone dealer imports Nokia and Motorola phones. In a given consignment, 55% were Nokia and 45% were Motorola phones. The probability that a Nokia phone is defective is 4%. The probability that a Motorola phone is defective is 6%. A phone is picked at random from the consignment. Determine that it is

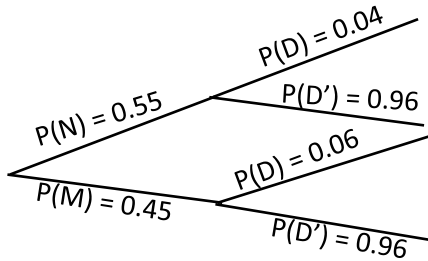

(i) defective = $P(N \cap D) + P(M \cap D) = 0.55 \times 0.04 + 0.45 \times 0.06 = 0.049$

(ii) a Motorola given that it is defective

$$P(M/D) = \frac{P(M \cap D)}{P(D)} = \frac{0.45 \times 0.06}{0.049} = 0.551$$

Thank You

Dr. Bbosa Science