



Primary 7 Integrated Science

Term 2

Theme: Matter Energy

Topic 1/3 – Simple Machines and Friction

Learning Outcomes: The learner:

- appreciates the importance of machines in everyday life situations.
- develops the capacity to simplify work by using knowledge and principles to make and use simple machines

Force

A force is the pull, push or a lift on an object.

Force is measured in Newtons using a spring balance

Effect of force on an object

- It makes stationary object move
- It makes a moving object to stop or increase speed
- It changes the direction of a moving object
- It changes the shape of an object.

Types of force

- Weight
- Gravity
- Friction
- Magnetic

Weight

Is the amount of force of gravity acting on an object. Weight may vary from one place to another depending of acceleration due gravity

Gravity

Is the force that pulls thngs towards the center of the earth. Forinstance stones through up fall due to gravity.

Inertia is a property of matter that causes it to resist changes in velocity. Either an object remain at rest or continue with constant velocity.

Friction

This is a force that oppose motion or movement

Advantages of friction

- (i) Prevents us from falling while walking
- (ii) Enables us to write with a pencil or a pen
- (iii) Enable us to use a rubber to ezae
- (iv) Cause heat between match box and match stick leading to lighting of match stick

Disadvantage of friction

- (i) wears out shoe, tyres, machines
- (ii) produces unnecessary sound
- (iii) produces unnecessary heat
- (iv) increases effort required to move
- (v) causes blisters on hands

Methods of reducing friction

- oiling
- using ball bearing
- using rollers

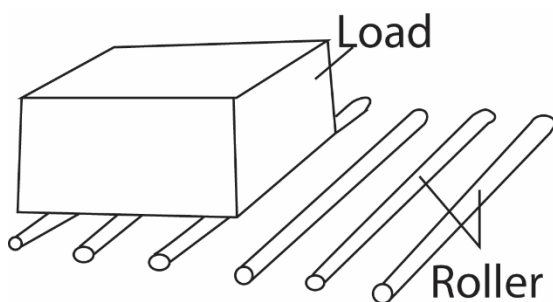

- smoothing surface

- making objects streamline like boat or aeroplane

Ways of increasing friction

- making surfaces rough e.g. tarmaking road.
- Having no air trapped between surfaces

Machines

A machine is a device that makes work easier.

In machines an effort (force in newton) is applied to move the load.

The effort can be

Muscular effort from man or

Force derived from an engine.

Principle of simple machines

The principle used in a simple machine is to produce **a big force over a small distance** by using **a small force over large distance**.

The force which we apply to the machine is known as **effort (E)** and the load we have to overcome is known as the **load (L)**. Both force and load are measured in Newton.

Examples of simple machines

They include levers, pulley, hydraulic, gears, screws, and inclined planes

Levers

A lever is a rigid bar which is free to move about a fixed point, the Fulcrum or pivot

Levers are divided into three classes

- (i) The first class levers
- (ii) The second class lever and,
- (iii) Third class levers

(a) First class lever

This is a type of lever in which the fulcrum is between the effort and the load.

Examples of first class lever include Crow bar, scissor, beam balance, scissor and pair of pliers,

Examples

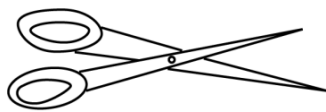
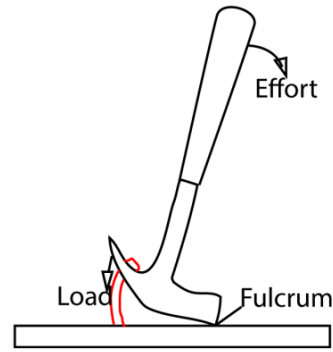
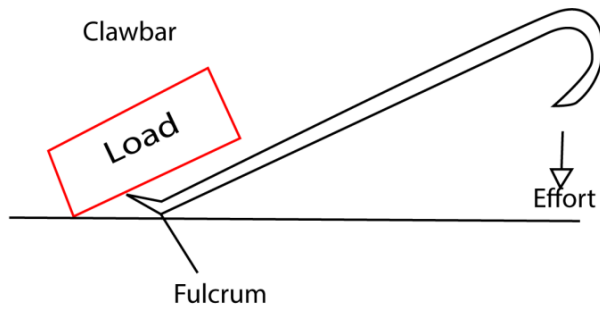

Pair of scissors

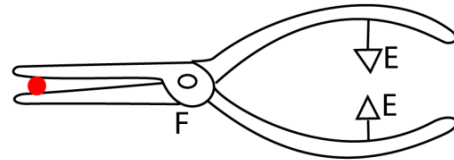

Pair of pliers

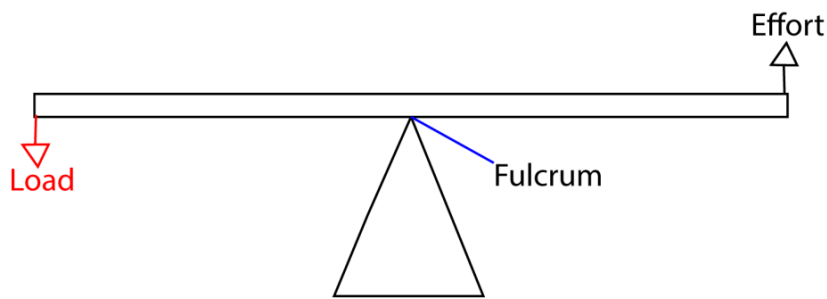

Beam balance

The Principle of Moments

States that when a body is balanced, the total clockwise moment about a point equals the total anticlockwise moment about the same point.

Equation

Moment = force F x perpendicular distance from the pivot d .

Moment = Fd

Example 1

A boy applies a force of **20 N** at the end of a spanner of length **0.5 m**. Find the **moment of the force** about the point where the spanner turns.

Solution

The formula for moment is:

Moment = Force \times Distance from pivot

Moment = 20 N \times 0.5 m

Moment = 10 Nm

(b) Second class lever

Here the load is between the effort and fulcrum.

Examples are wheelbarrow, nut cracker and office punch

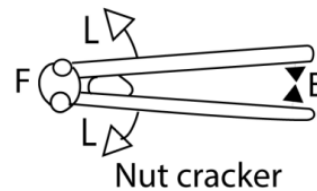
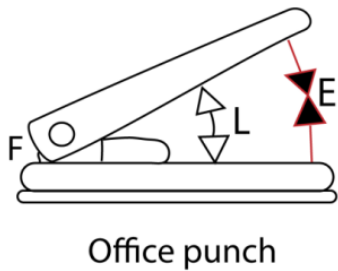
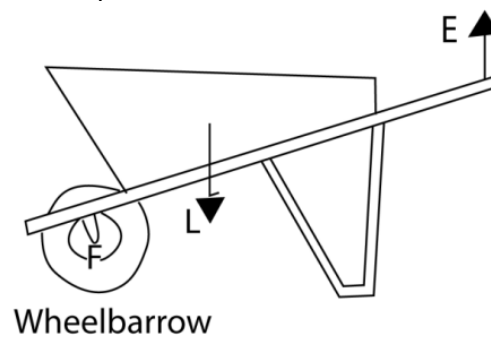
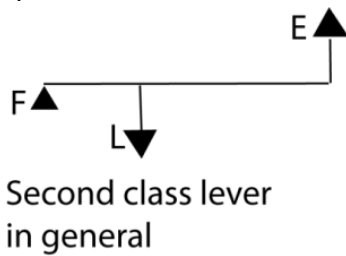

(c) Third class lever

Here the effort is between the load and fulcrum.

Examples are wheelbarrow, nut cracker and office punch

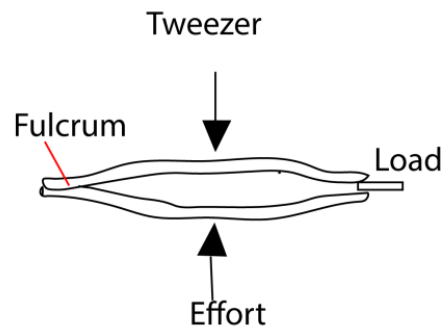
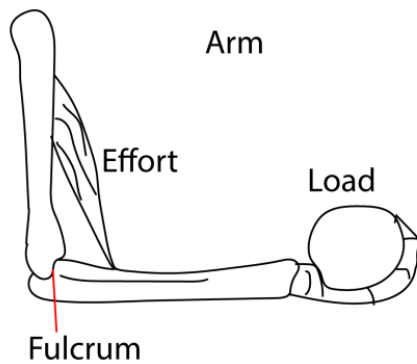
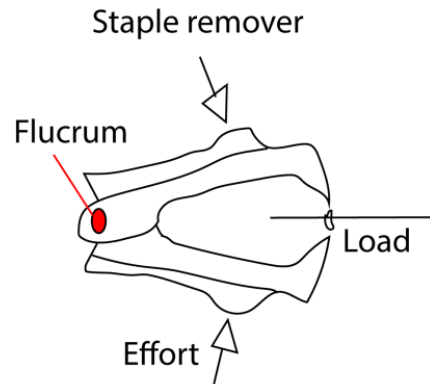
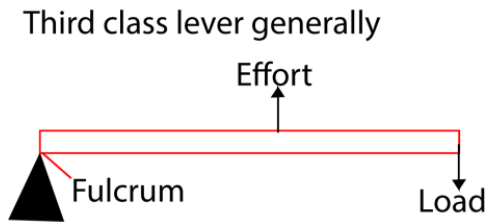

Example 2

In the diagram below Isaac and Susan sit on seesaw above, such that Isaac sits at point X and Susan at point Y. Find the mass of Isaac if Susan weighs 45kg.



Principle: clockwise moment = anticlockwise moment.

Let the mass of Isaac be M

Taking moments at the fulcrum

Clockwise moment = $4 \times 45 = 180\text{gm}$

Anticlockwise moment = $M \times 6 = 180\text{gm}$

$$M = \frac{180}{6} = 30\text{kg}$$

Therefore, Isaac weighs 30kg

Mechanical advantage (M.A)

This is the ratio between the load and the effort applied.

$$\text{i.e } M.A = \frac{\text{Load (L)}}{\text{Effort (E)}}$$

Significance of mechanical advantage

The bigger the mechanical advantage the better the machine since small effort can lift a bigger load.

Velocity ratio

This is the ratio of distance moved by effort over the distance moved by the load

$$\text{i.e. Velocity ratio (V.R)} = \frac{\text{distance moved by effort}}{\text{distance moved by load}}$$

Velocity ratio has no units

Significance of velocity ratio

The bigger the velocity ratio the less effort required to do work and the more efficient the machine. Or the machines requires less effort to overcome a big load when effort moves a bigger distance compared to the load in a unit time.

Example 3

A load of 100N is raised through 6m when an effort of 40N moves through 24m.

Calculate

- (i) mechanical advantage
- (ii) velocity ratio

Solution

$$(i) \quad M.A = \frac{\text{Load (L)}}{\text{Effort (E)}} = \frac{100}{40} = 2.5$$

(ii) Velocity ratio (V.R) = $\frac{\text{distance moved by effort}}{\text{distance moved by load}} = \frac{24}{6} = 4$

Pulleys

A **pulley system** is a simple machine made up of one or more pulleys (wheels with a groove) and a rope or chain.

- A pulley system is used to **lift or move heavy loads** more easily.
- The rope runs over the pulley wheel, and when you pull the rope, the load is lifted.

Types of pulley systems include:

Types of pulleys

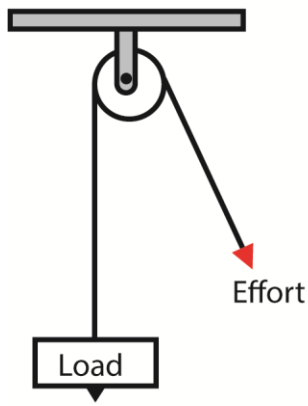

Single Fixed,

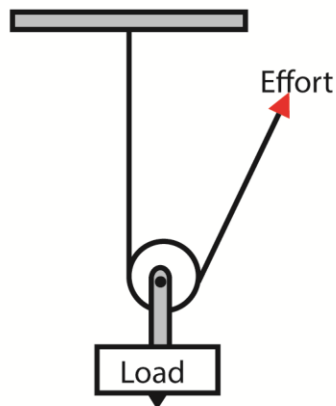

Single Movable

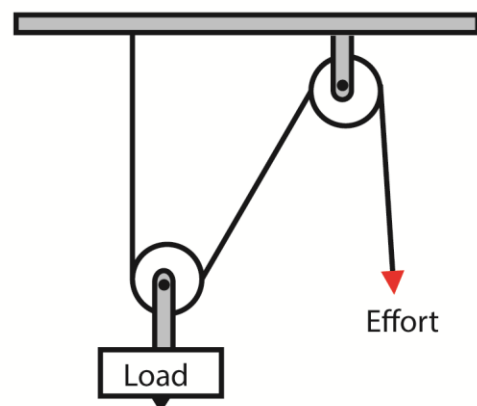

Combination (Block and Tackle)

Key Points:

- **Single fixed pulley** – changes the direction of force.
- **Single movable pulley** – reduces the effort needed.
- **Combination (block and tackle)** – both fixed and movable pulleys working together to make lifting heavy loads much easier.

Application of single pulley system

- Removing water from a well
- Lifting building material in the site
- Used on a flag post in the school
- Used at the port to load and unload ship

Exercise 4

- (a) Name any three types of pulley
- (b) Give any one use of pulleys.

Inclined Plane

This refers to a type of a machine in which a plane is inclined to an angle to the horizontal such that one end is higher than the other by angle, θ .

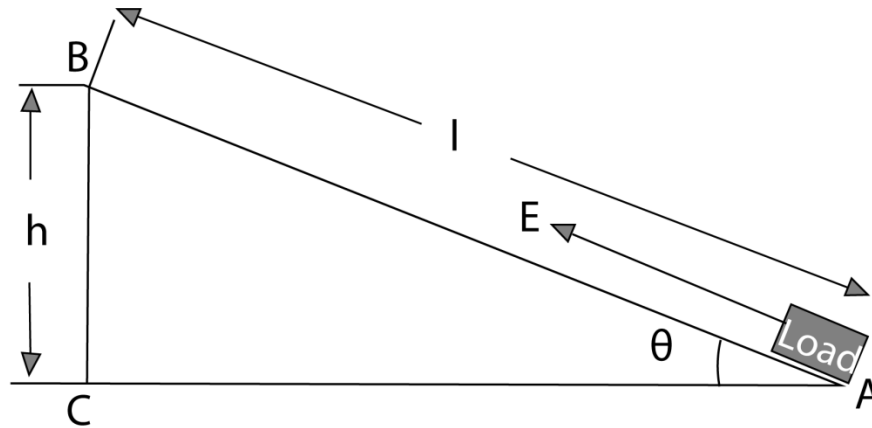

- it used to lift heavy load by pulling/pushing it along the sloping surface.
- It is easier to carry the load along the slope than lifting it through the vertical height, h , since the weight of the load acts vertically downwards (and only a component of weight acts along the plane)
- In order to raise the load through a vertical height, h , the effort, E is applied through a longer distance, l , equal to the length of the plane.

Examples of inclined plane include

- (i) Ladder
- (ii) Slopping roads
- (iii) Stair case
- (iv) Winding road

Exercise 5

State any two examples of inclined planes.

The Wedges

The wedge is a kind of simple machine which is an inclined plane having one or two sloping sides. With a wedge, the sloping surface is pushed through the material which is held still.

Examples of wedges are: Knife, axe, chisel, needle, nail, razor blade

Uses of wedges include: Cutting, pitching

Examples of wedges

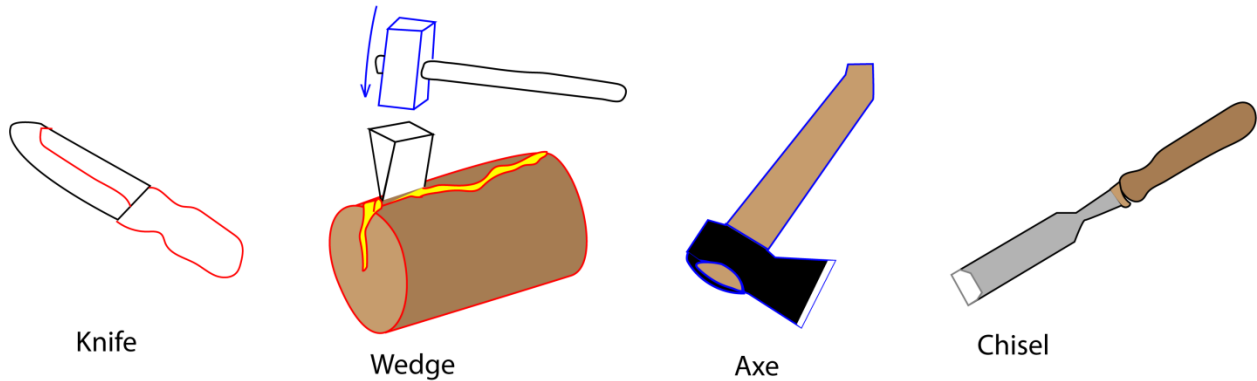

Uses of Wedges

- (i) **Splitting wood** – axes and chisels are wedges used to cut or split logs.
- (ii) **Cutting food** – knives are wedges that help slice fruits, vegetables, and meat.
- (iii) **Holding objects in place** – doorstops are wedges that keep doors open or closed.
- (iv) **Breaking hard surfaces** – wedges like chisels are used in construction to break stones or concrete.
- (v) **In farming tools** – wedges are found in hoes and ploughs to dig into the soil.
- (vi) **In nails and pins** – the pointed ends act like wedges to push into materials.

Exercise 6

Using examples give any two uses of wedges

Wheel and axle

A wheel and axle is a type of simple machine made up of a wheel and axles rigidly attached to each other so that they turn together about an axis.

The effort is applied to the larger wheel and the load is raised by string attached to the axle of small diameter as show below:

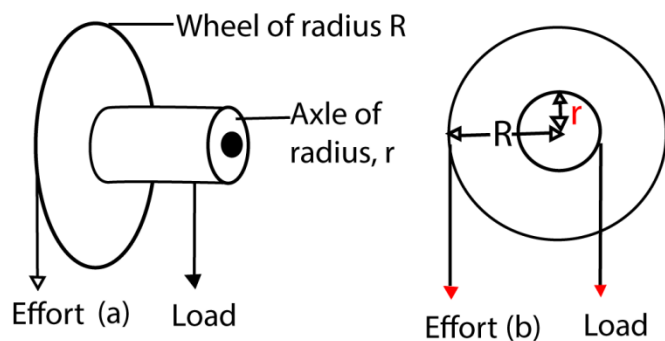

Uses of wheel and axle

- (i) The car steering wheel
- (ii) Screw driver
- (iii) Windlass (used to raise a heavy bucket of water in a well).
- (iv) **Bicycle** – the pedals and wheels use the wheel-and-axle principle.
- (v) **Car steering wheel** – turning the wheel moves the axle to steer the car.
- (vi) Door **knob** – the knob (wheel) turns the shaft (axle) to open the door.
- (vii) Water **borehole pump handle** – the handle acts as a wheel turning the axle to lift water.

Gears

A gear is a device which consists of a set of toothed wheels. Gears change the direction and speed of rotation. They are similar to wheel and axle. In gear wheel, the effort and the load are applied to the shafts connected to gear.

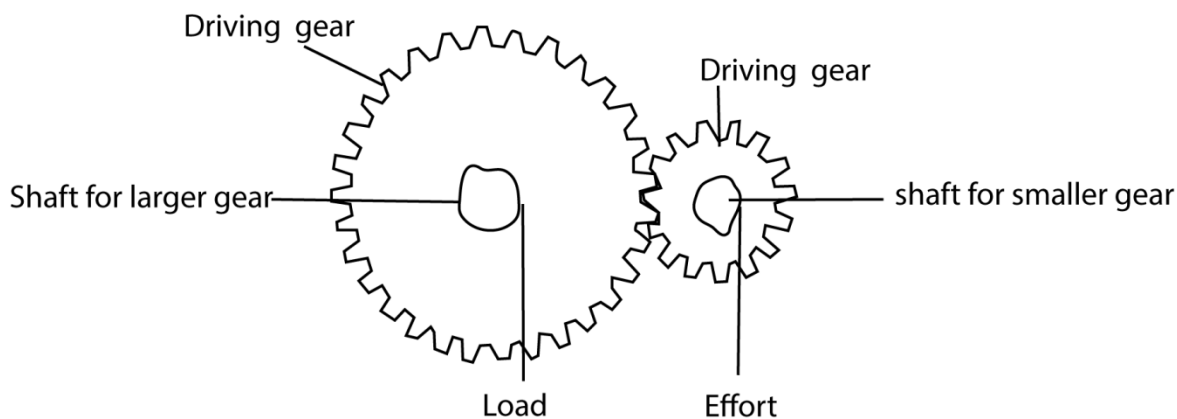

Uses of Gears

- (i) **In bicycles** – gears help change speed and make pedaling easier or harder depending on the terrain.

- (ii) **In vehicles** – gears in cars, motorcycles, and trucks control speed and power.
- (iii) **In clocks and watches** – gears help move the hands smoothly to show time.
- (iv) **In machines** – gears transfer motion and force in engines, sewing machines, and factory machines.
- (v) **In wind-up toys** – gears make the toy parts move when wound.
- (vi) **In lifts and cranes** – gears help lift heavy loads safely.

The screw

A screw may be considered as continuous inclined plane wound round a cylindrical threaded rod.

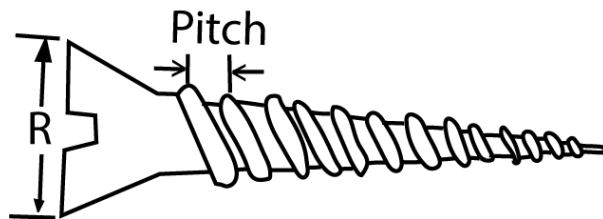

- The distance between two successive threads is called a pitch

Uses of Screws

- (i) **Joining materials** – screws are used to fasten pieces of wood, metal, or plastic together.
- (ii) **Building furniture** – chairs, tables, and cupboards are held firmly with screws.
- (iii) **Construction** – screws are used in houses, bridges, and machines to hold parts in place.
- (iv) **Electronics and appliances** – screws keep parts of radios, TVs, and phones tightly fixed.
- (v) **Transport** – vehicles like cars, bicycles, and motorcycles use screws to hold parts together.
- (vi) **Tools and machines** – screws are used in engines, farm tools, and other equipment.
- (vii) **Medical use** – special screws are used in surgery to fix broken bones.

Exercise 7

Give any two uses of screws.

Summary of simple Machines

Simple Machine	How it Makes Work Easier	Examples
Lever	Reduces effort by using a pivot (fulcrum)	Seesaw, crowbar, panga, scissors
Pulley	Changes direction of force, reduces effort	Flagpole rope, crane pulley, borehole pulley
Wheel & Axle	Increases speed, reduces friction	Bicycle, car steering wheel, door knob
Inclined Plane	Allows heavy loads to be moved upward with less effort	Ramp, staircase, slide
Wedge	Splits or cuts materials, holds objects	Knife, axe, chisel, nail
Screw	Converts turning force into forward movement, holds things tightly	Bottle cap, drill, car jack screw

Revision questions

1. The diagram below is a simple machine. Use it to answer the questions that follow

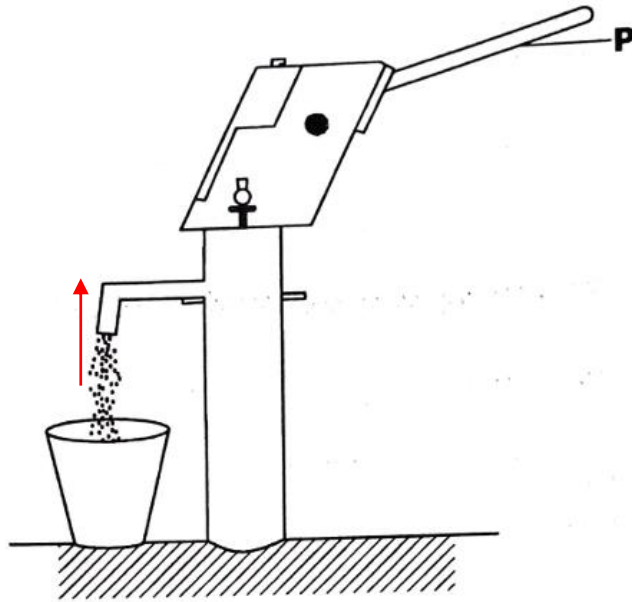

- (a) Name the class of levers to which the above machine belongs.
wheel and axle system
- (b) Using an arrow, show the direction of the load when effort is applied to the part labelled P.
- (c) State any two ways of improving efficiency of the above simple machine
- (i) **Regular maintenance** – clean and check the pump parts to avoid rust and blockages.
 - (ii) **Use quality materials** – strong pipes and durable pump systems last longer and work better.
 - (iii) **Proper sealing** – prevent dirty water from entering by sealing the borehole well.
 - (iv) **Train users** – teach people how to operate the pump correctly to avoid damage.
 - (v) **Install a good drainage system** – prevent water from pooling around the borehole, which can weaken the structure.
 - (vi) **Lubricate moving parts** – reduce friction and wear to keep the pump working smoothly.

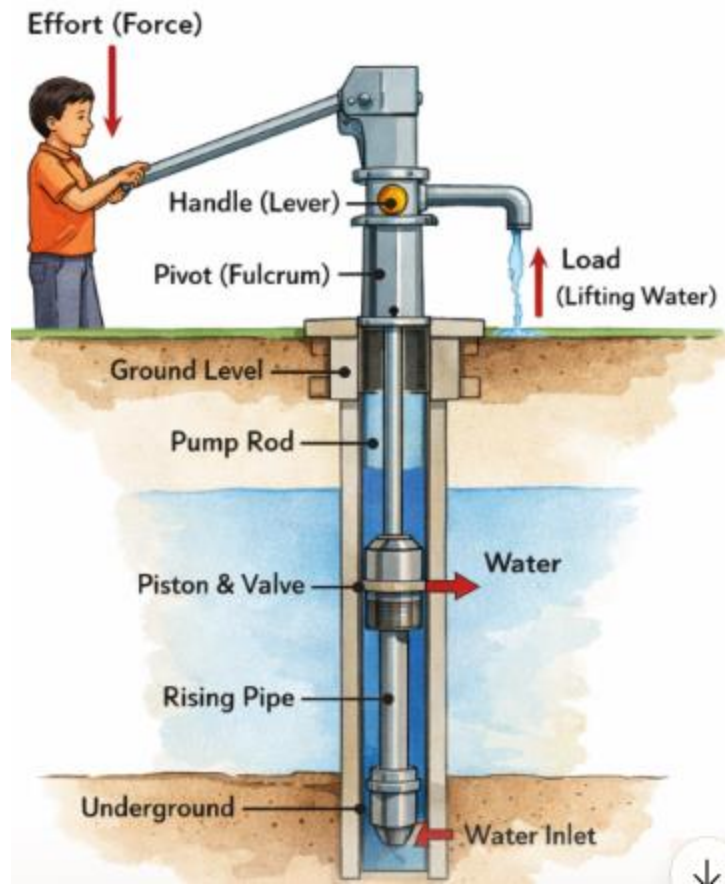

How a borehole work

- (i) The **handle** acts as a **lever**.
- (ii) The **pivot (fulcrum)** is the point where the handle is fixed.
- (iii) When effort is applied on the handle, the **pump rod** moves up and down.
- (iv) This action lifts water through the **rising pipe** from underground to the spout.

☞ **Summary:** A borehole works as a lever system because the handle (lever) uses effort around a pivot to lift water (the load).

2. State any one reason why a builder prefer a pulley to inclined plane when lifting sand from the ground to the top of a building.
 - (i) The pulley uses less effort,
 - (ii) The pulley requires a small spaces to lift heavy loads straight up.
3. (a) Name the group of simple machines to which each of the following tools belongs,
 - (i) Ladder : inclined plane
 - (ii) Panga: third class
 (b) Give any two ways in which simple machines make work easier
 - (i) **Reduce effort needed** – e.g., a lever allows you to lift heavy loads with less force.

- (ii) **Change direction of force** – e.g., a pulley lets you pull down to lift something up.
- (iii) **Increase speed or distance** – e.g., a wheel and axle makes movement faster and smoother.
- (iv) **Hold objects firmly** – e.g., screws and wedges keep materials tightly fixed together.
- (v) **Cut or split materials** – e.g., knives, axes, and chisels (wedges) make cutting easier.
- (vi) **Lift heavy loads safely** – e.g., inclined planes allow rolling or sliding objects upward instead of lifting directly.

4. The diagram below shows a simple machine. Study it and answer the questions that follow

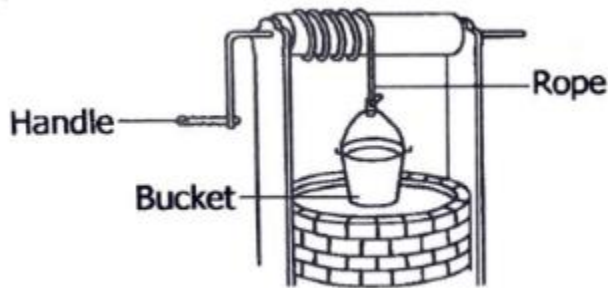

- (a) To which type of simple machine does the machine above belong?
Wheel and axle
- (b) State any one use of the simple machine above.
To remove water from a deep well
To remove soil from a deep pit
- (c) Name any one force that makes work difficult when using the above machine
Gravitation force
- (d) Give one other example of machine that belongs to above type of simple machine
 - (i) The car steering wheel
 - (ii) Screw driver
 - (iii) Windlass (used to raise a heavy bucket of water in a well).

5. The diagram below is of a crow bar. Study and use it to answer the questions that follow.

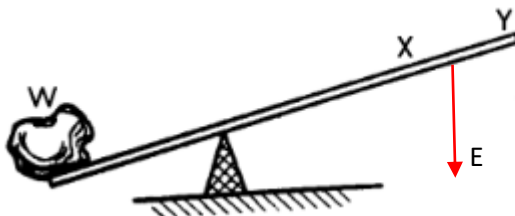

- (a) Which of the two positions X and Y requires less effort to overcome the load W.
Y
- (b) Indicate on the diagram with an arrow E, the direction of the effort used to overcome the load W.
6. Give one reason why less effort is applied to move a load using first class levers
Less effort is used when it farther from the pivot than the load
7. The diagram below shows a man using a machine to load a drum on to a truck. Study and use it to answer the questions that follow.

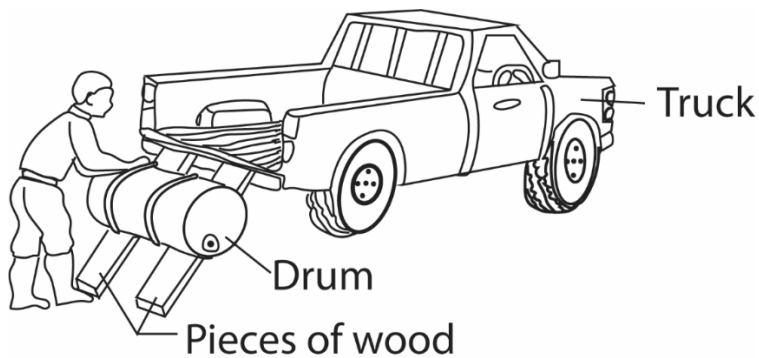

- (a) What type of simple machine is the man using?
Inclined plane
- (b) Give any two examples of the type of simple machine you have named in (a) above.
Ladder
Inclined road
- (c) How can the man improve on the simple machine in order to make his work easier?
Use long pieces of wood to reduce the slope of the inclined plane
8. State the class of lever in which the foot is between the fulcrum and the load
Third class lever
9. The diagram below shows a man using a pole for lifting a piece of stone. Use it to answer questions 1 and 2.

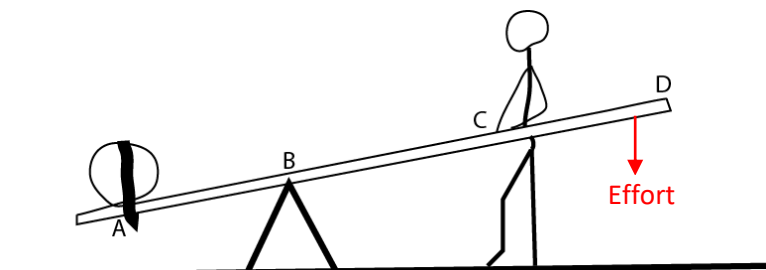

- (a) On the diagram, show the direction of the effort.
- (b) What should the man do to lift the load more easily?

He should apply effort on position D to make work easier.

10. Bbosa pulls a load of 50kg over a set of metal rollers. Peter pulls another load of the same weight along the ground (see diagram below)

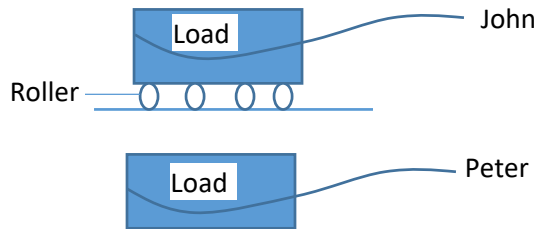

- (a) Explain why one of the two (people) uses less force.

John uses less force because the rollers minimize friction at the surface

- (b) What is the advantage of a driver pouring sand on a slippery road.

To increase friction to facilitate movement.

- (c) Explain your answer in (b) above?

Sand makes slippery road rough which increases friction

11. Bob and Agnes are sitting, balanced, on a seesaw as shown in the diagram below.

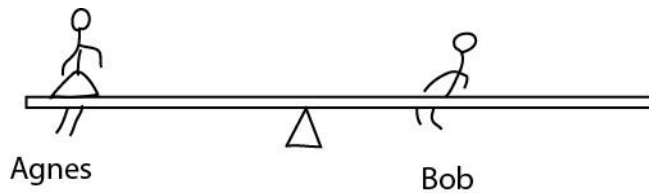

How does the diagram show that Bob is heavier?

Bob balances Agnes who sits further from the fulcrum

12. The diagram below shows two boys. Musa and Juma pulling pieces of wood of equal weight up the wall. Use it to answer questions that follow

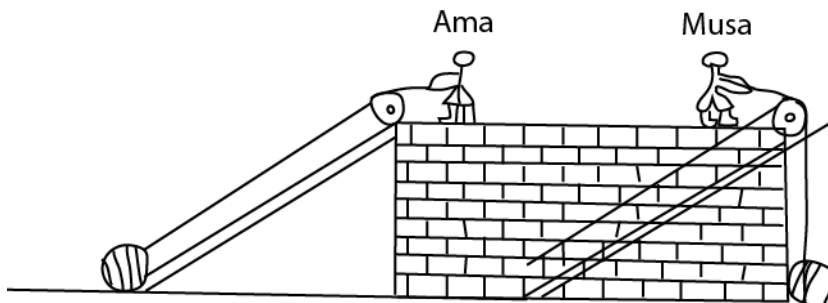

- (a) Which boy uses less force to pull wood?

Ama

(b) Explain your answer to question 33 above.

Inclined plane reduced the effort required

13. The diagram below shows a boy collecting water from a water pump. Use it to answer the questions that follow.

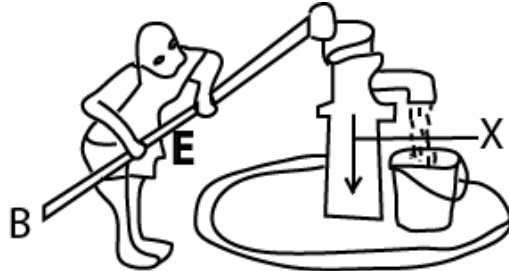

(a) Mark on the diagram with letter E the position of the effort.

(b) What does the part marked X represent?

Atmospheric pressure

(c) What change would the boy experience if he moved the hands to position B?

He would use less effort to pump water

(d) If the effort is 20, and the load is 80, what is the mechanical advantage of the pump?

$$\text{Mechanical advantage} = \frac{\text{load}}{\text{effort}} = \frac{80}{20} = 4$$

14. When drawing water from a borehole, why is the handle led far from the fulcrum?

To use less effort

15. The diagram above shows the foot of a driver accelerating the car. Indicate on it with letter L, the position of the load

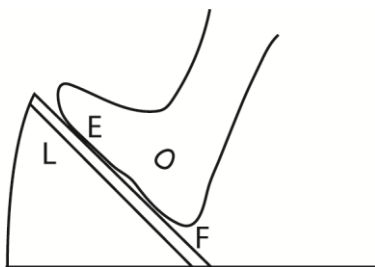

16. The diagram below shows a machine used to lift a load using an effort of 50kg

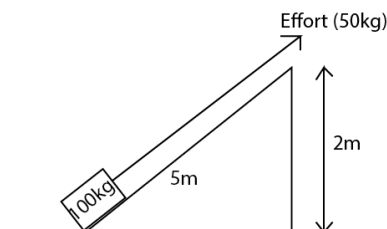

(a) Name the machine.

Inclined plane

(b) What distance does the load and effort move through?

Load moves 2m while effort 5m

(c) How can you use less than 50kg to pull the load?

Reduce the angle of inclination

17. Use the diagram below to answer question 11.



Isaac who weighs 30kg and Susan who weight 45kg sit on seesaw above, such that Isaac sits at point X and Susan at point Y. which side of the seesaw go down?

Taking moments at the fulcrum

Clockwise moment = $4 \times 45 = 180\text{gm}$

Anticlockwise moment = $30 \times 6 = 180\text{gm}$

Since clockwise moment = anticlockwise moment, the seesaw balances.

18. In the diagram below, what class of lever is represented?

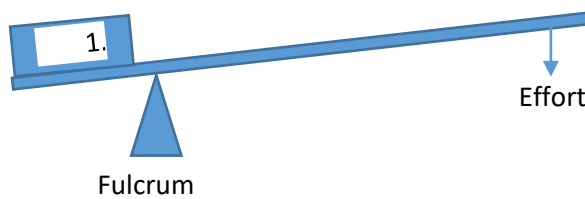

First class lever.

19. In the diagram, Moses is pulling a load the ground surface, as shown below.

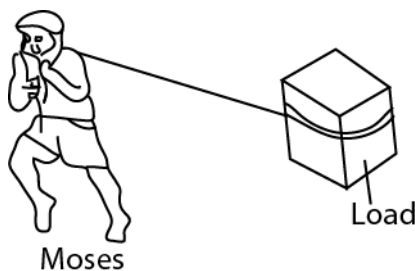

How could Moses make his work easier?

By using rollers

Smoothing the surface

20. In terms of machines, how is the hammer similar to the human arm?

Both make work easy

21. How do road builders increase friction on the surface of the road?

By adding sand or tarmacking

22. The diagram below shows a lever which is balanced. Use it to answer question that follow.

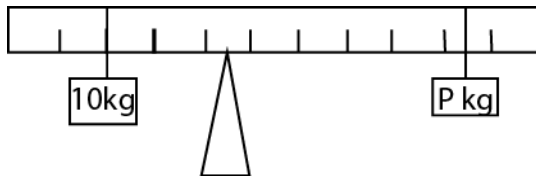

The diagram shows a lever which is balanced, calculate the weight of **P**.

Clockwise moment = anticlockwise moment

$$P \times 5 = 10 \times \frac{5}{2}$$

$$P = 5\text{kg}$$

23. Use the diagram of the machine below to answer the question that follow.

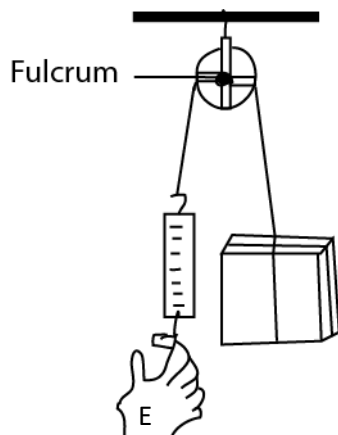

- (a) What is the name of such a machine?

Pulley

(b) What class is it?

First class lever

(c) Use letter E to show effort on the diagram.

(d) Which important activity in school is done using this machine?

Digging pit latrine, digging underground well

24. Apart from using more energy, name one other disadvantage of friction.

Wears out surfaces

Creates unnecessary heat

25. The diagram below is of a simple machine. Use it to answer questions that follow

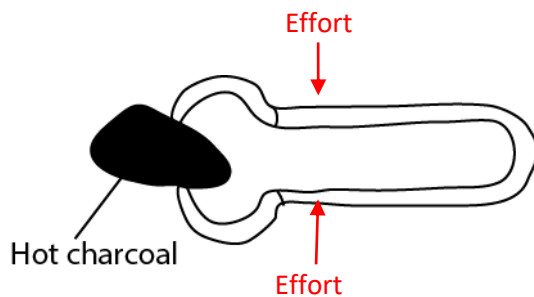

(a) Indicate with letter E the position of the effort.

(b) What class of lever is this machine?

Third class lever

26. Show the difference between the first-class lever and the second –class lever by drawing and labeling the two diagrams.

The first class lever, the fulcrum is between the load and effort while in second class lever, the load is between the fulcrum and effort.

(a) First –class lever

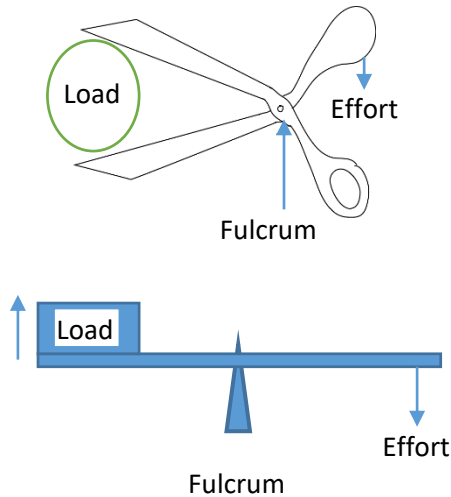

(b) Second –class lever

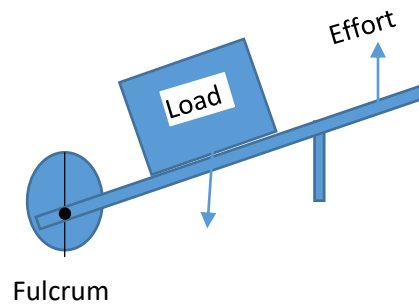

27. Peter uses a wheel barrow to carry potatoes from his garden to the market. What is the advantage of using such a machine?

Less effort is required

28. Give any one form of energy produced when a carpenter driver drives a nail into a piece of wood a harmer.

Sound energy

Heat energy

29. The diagram bellow show two types of simple machines labelled a and b

Use it to answer the questions that follow.

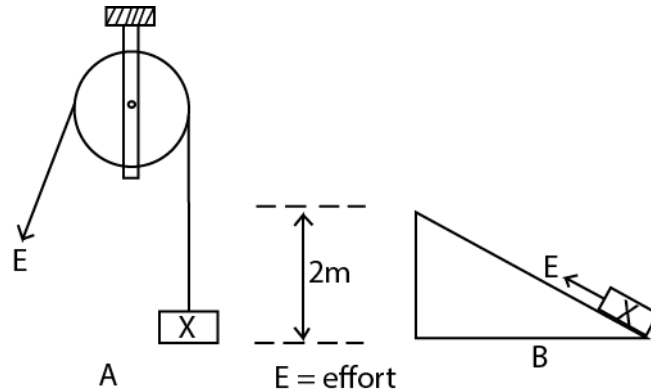

(a) Name each of the machines shown in the diagram

(i) **A: single fixed pulley**

(ii) **B: inclined plane**

(b) Which of the two machines would you choose to use to lift the load **X** to a height of two metres?

Inclined plane

(c) Give a reason for your choice of machine in (b) above.

Uses less effort

30. **The** diagram below shows a simple lever system

Use it to answer questions that follow

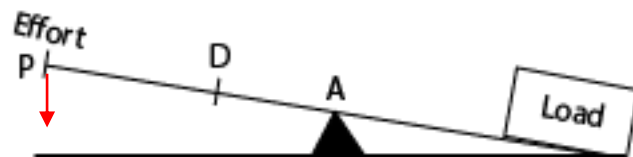

(a) Show on the diagram, with an arrow, the direction of movement of the effort at P as load is being lifted.

(b) At which of the two points D and P shown on the diagram will less effort be used to lift the load?

At P

(c) Give a reason for your answer in 38 above.

It is far from the pivot.

31. The diagram below shows two simple machines

Use it to answer the question that follow

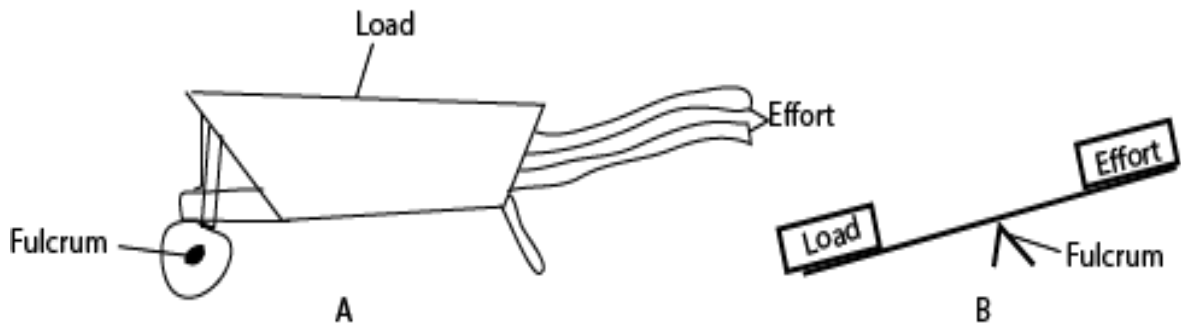

(a) Name the machine marked with the letter A

Wheel burrow

(b) State the class of lever to which each of the above machines belongs:

(i) machine A: **second class lever**

(ii) machine B: **first class lever**

(c) Give any one example of a machine which works in the same way as the machine marked with letter B

Pair of scissor

Priers

32. Give any one form of energy that is produced during the process of splitting firewood with an axe?

Heat energy

Sound energy

33. The diagram below shows a machine used for lifting loads

Use it to answer the question that follow.

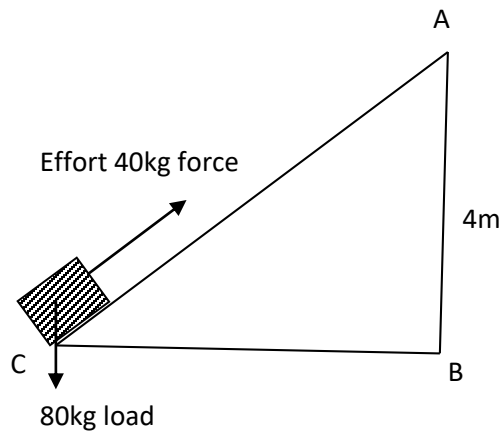

(a) What distance is the load to be lifted?

4m high

(b) Give the advantage of lifting the load alongside **CA**.

Less effort is used to make work easier

(c) Find the mechanical advantage of the machine above.

$$\mathbf{MA = \frac{Load}{Effort} = \frac{80}{40} = 2}$$

(d) How can the machine be improved so that less effort is used to lift loads.

By reducing the angle of inclination of the plane

34. The diagram below is of a pulley system. Use it use to answer questions that follow.

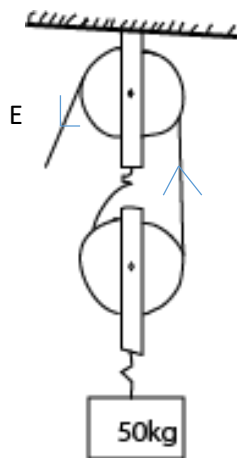

(a) Name the types of pulley system shown above

Block and tackle pulley system

(b) Use an arrow to show the direction of effort.

(c) If the mechanical advantage of the machine is 2 and the load being carried by the machine is 50kg. Find the effort needed to raise that load.

$$MA = \frac{L}{E} = \frac{50}{E} = 2$$

$$E = \frac{50}{2} = 25kg$$

$$E = 25 \times 10 = 250N$$

35. Name the class of simple machines to which an axe belongs.

Wedge

36. Name the turning point of a machine.

Fulcrum

37. State any one way in which friction in moving parts of a machine can be reduced.

- **By oiling**
- **By greasing**
- **by using roller**
- **By using ball bearings**

38. An irregular object was lowered into an overflow can **A** containing water. The water it displaced was collected in container **B** as shown below.

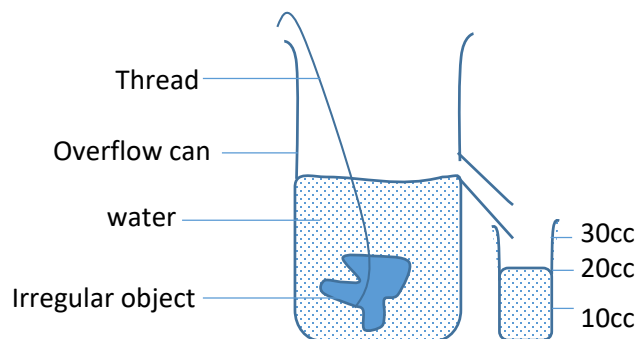

(a) What is the volume of the irregular object?

20cm³

(b) Calculate the density of the irregular object if its mass is 60 g

$$\text{Density} = \frac{\text{mass}}{\text{volume}} = \frac{60}{20} = 3gcm^{-3}$$

39. To which class of levers does a wheel barrow belong?

Second class lever.

40. Use it to answer questions follow

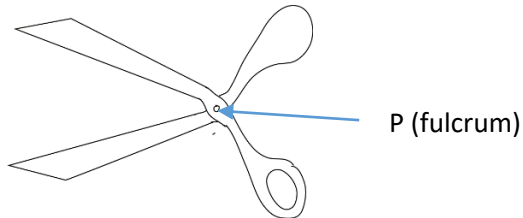

(a) To which class of levers does the machine above belong?

First class lever

(b) Put letter P if the position of fulcrum

41. Give one reason why less effort is applied to move a load using first class levers.

The effort is applied further from the fulcrum than the load

42. The diagram below shows a man using a simple machine to load a drum on to a truck. Study and use it to answer the questions that follow

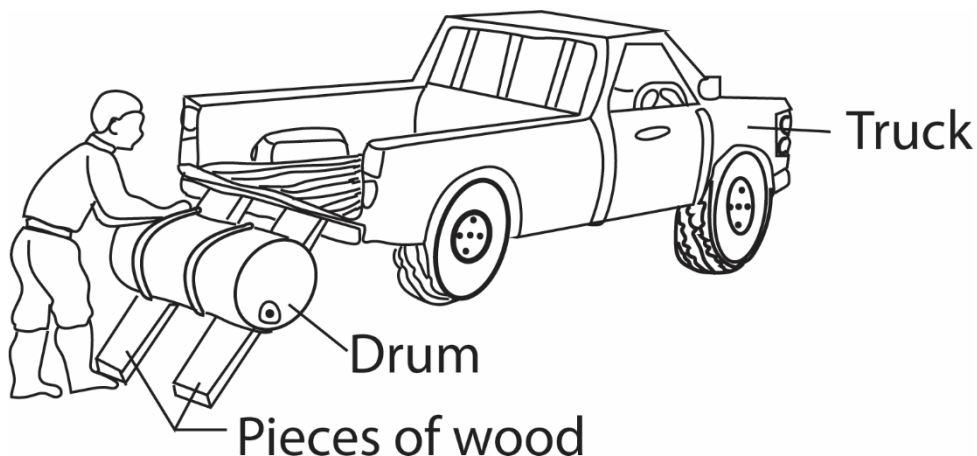

(a) What type of simple machine is the man using?

Inclined plane

(b) Give any two examples of the type of simple machines you named in (a) above

(i) Ladder

(ii) Inclined load

(c) How can the man improve on the simple machine above in order to make his work easier?

Make piece of wood long to reduce the inclination

43. The diagram below is of a crow bar. Study and use it to answer questions 44 and 45

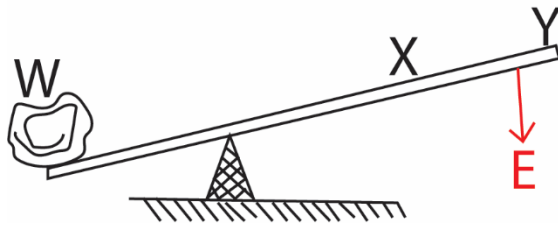

(a) Which of the two positions X and Y requires less effort to overcome the load W?

At Y

(b) Indicate on the diagram with an arrow E, the direction of the effort used to overcome the load W.

Thank You

Dr. Bbosa Science